

AC centrifugal fan

forward-curved, single-intake

with housing (flange)

G2E146-BF01-41 ebmpapst Datasheet

sales@fansco.com

www.fansco.com

Nominal data

| | | |
|-----------------------------|-------------------|---------|
| Type | G2E146-BF01-41 | |
| Motor | M2E068-EC | |
| Phase | | 1~ |
| Nominal voltage | VAC | 230 |
| Frequency | Hz | 50 |
| Method of obtaining data | | fa |
| Valid for approval/standard | | - |
| Speed (rpm) | min ⁻¹ | 2200 |
| Power consumption | W | 280 |
| Current draw | A | 1.22 |
| Capacitor | μF | 6 |
| Capacitor voltage | VDB | 400 |
| Capacitor standard | | S0 (CE) |
| Min. back pressure | Pa | 0 |
| Min. back pressure | in. wg | 0 |
| Min. ambient temperature | °C | -25 |
| Max. ambient temperature | °C | 50 |

ml = Max. load · me = Max. efficiency · fa = Free air · cs = Customer specification · ce = Customer equipment
Subject to change



AC centrifugal fan

forward-curved, single-intake
with housing (flange)

Technical description

| | |
|--|--|
| Weight | 4 kg |
| Size | 146 mm |
| Motor size | 68 |
| Rotor surface | Painted black |
| Impeller material | Sheet steel, painted black |
| Housing material | Die-cast aluminum, painted black |
| Direction of rotation | Counterclockwise, viewed toward rotor |
| Degree of protection | IP44; installation- and position-dependent |
| Insulation class | "F" |
| Moisture (F) / Environmental (H) protection class | H2; F2-2 |
| Max. permitted ambient temp. for motor (transport/storage) | + 80 °C |
| Min. permitted ambient temp. for motor (transport/storage) | - 40 °C |
| Installation position | Any |
| Condensation drainage holes | None |
| Mode | S1 |
| Motor bearing | Ball bearing |
| Touch current according to IEC 60990 (measuring circuit Fig. 4, TN system) | < 0.75 mA |
| Motor protection | Thermal overload protector (TOP) with basic insulation |
| Protection class | I (with customer connection of protective earth) |
| Conformity with standards | EN 60335-1 |



AC centrifugal fan

forward-curved, single-intake
with housing (flange)

Product drawing

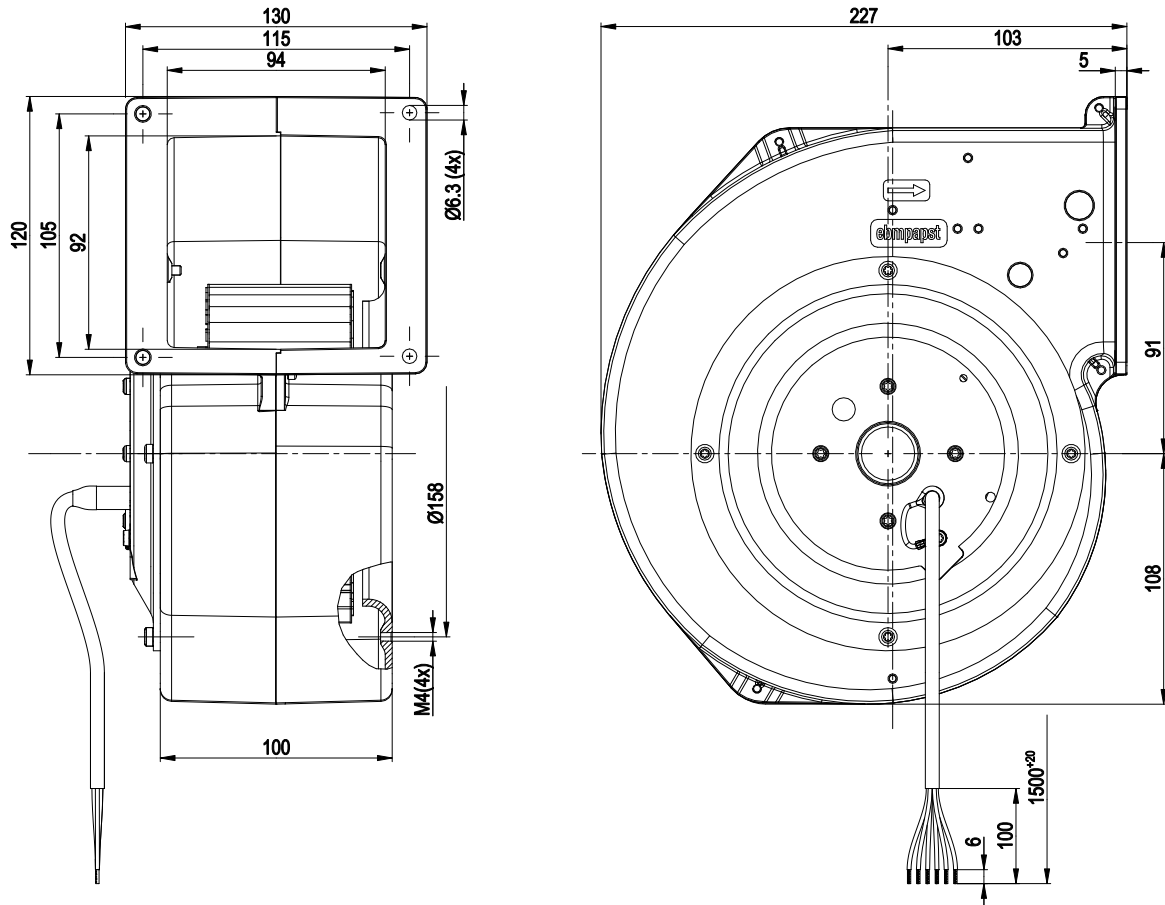

1 Cable halogen-free 6G 0.5 mm², 6x crimped splices

Connection diagram

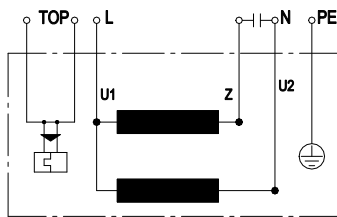

| | | | | | |
|----|--------------|-----|----------|----|-------|
| U1 | blue | Z | brown | U2 | black |
| PE | green/yellow | TOP | 2x white | | |



AC centrifugal fan

forward-curved, single-intake

with housing (flange)

Curves: Air performance 50 Hz

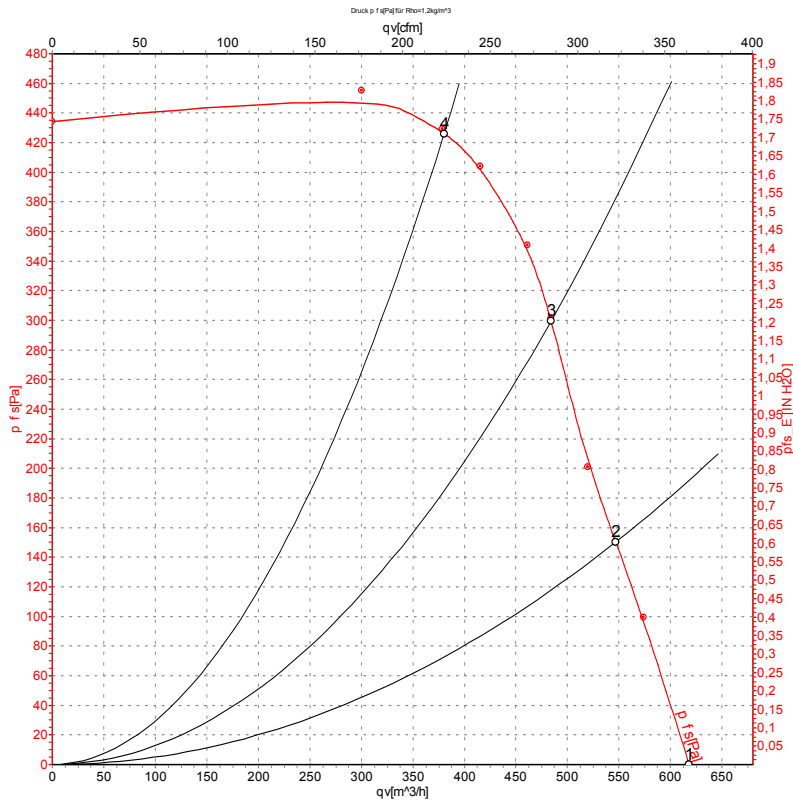

Measurement: LU-4787-1

Air performance measured according to ISO 5801 installation category A. For detailed information on the measurement setup, contact ebm-papst. Intake sound level: Sound power level according to ISO 13347 / sound pressure level measured at 1 m distance from fan axis. The values given are valid under the specified measuring conditions and may vary due to conditions of installation. For deviations from the standard configuration, the parameters have to be checked on the installed unit.

Measured values

| | U | f | n | P _e | I | q _v | P _{fs} | q _v | P _{fs} |
|---|-----|----|-------------------|----------------|------|-------------------|-----------------|----------------|-----------------|
| | V | Hz | min ⁻¹ | W | A | m ³ /h | Pa | cfm | in. wg |
| 1 | 230 | 50 | 2200 | 280 | 1.22 | 620 | 0 | 365 | 0.00 |
| 2 | 230 | 50 | 2430 | 238 | 1.03 | 545 | 150 | 320 | 0.60 |
| 3 | 230 | 50 | 2540 | 214 | 0.92 | 485 | 300 | 285 | 1.20 |
| 4 | 230 | 50 | 2670 | 178 | 0.78 | 380 | 425 | 225 | 1.71 |

U = Voltage · f = Frequency · n = Speed (rpm) · P_e = Power consumption · I = Current draw · q_v = Air flow · p_{fs} = Pressure increase

