

G2E133-DN77-27

AC centrifugal fan

forward-curved, single-intake
with housing (without flange)



G2E133-DN77-27 ebmpapst Datasheet

sales@fansco.com

www.fansco.com

Nominal data

| | | | |
|-----------------------------|--------------------|------|------|
| Type | G2E133-DN77-27 | | |
| Motor | M2E068-BF | | |
| Phase | | 1~ | 1~ |
| Nominal voltage | VAC | 230 | 230 |
| Frequency | Hz | 50 | 60 |
| Method of obtaining data | | fa | fa |
| Valid for approval/standard | | CE | CE |
| Speed (rpm) | min ⁻¹ | 2150 | 2100 |
| Power consumption | W | 88 | 110 |
| Current draw | A | 0.39 | 0.49 |
| Capacitor | µF | 2 | 2 |
| Capacitor voltage | VDB | 450 | 450 |
| Min. back pressure | Pa | 0 | 0 |
| Min. back pressure | inH ₂ O | 0 | 0 |
| Min. ambient temperature | °C | -25 | -25 |
| Max. ambient temperature | °C | 55 | 50 |

ml = Max. load · me = Max. efficiency · fa = Free air · cs = Customer specification · ce = Customer equipment
Subject to change



AC centrifugal fan

forward-curved, single-intake
with housing (without flange)

Technical description

| | |
|---|---|
| Weight | 1.9 kg |
| Fan size | 133 mm |
| Rotor surface | Unpainted |
| Impeller material | Sheet steel, galvanized |
| Housing material | Sheet steel, galvanized |
| Direction of rotation | Clockwise, viewed toward rotor |
| Degree of protection | IP44; installation- and position-dependent |
| Insulation class | "B" |
| Moisture (F) / Environmental (H) protection class | H0 - dry environment |
| Max. permitted ambient temp. for motor (transport/storage) | + 80 °C |
| Min. permitted ambient temp. for motor (transport/storage) | - 40 °C |
| Installation position | Any |
| Condensation drainage holes | None |
| Mode | S1 |
| Motor bearing | Ball bearing |
| Touch current according to IEC 60990 (measuring circuit Fig. 4, TN system) | < 0.75 mA |
| Motor protection | Thermal overload protector (TOP) internally connected |
| With cable | Axial |
| Protection class | I (with customer connection of protective earth) |
| Conformity with standards | EN 60335-1; CE |
| Approval | UL 1004-1; CSA C22.2 No. 100 |



AC centrifugal fan

forward-curved, single-intake
with housing (without flange)

Product drawing

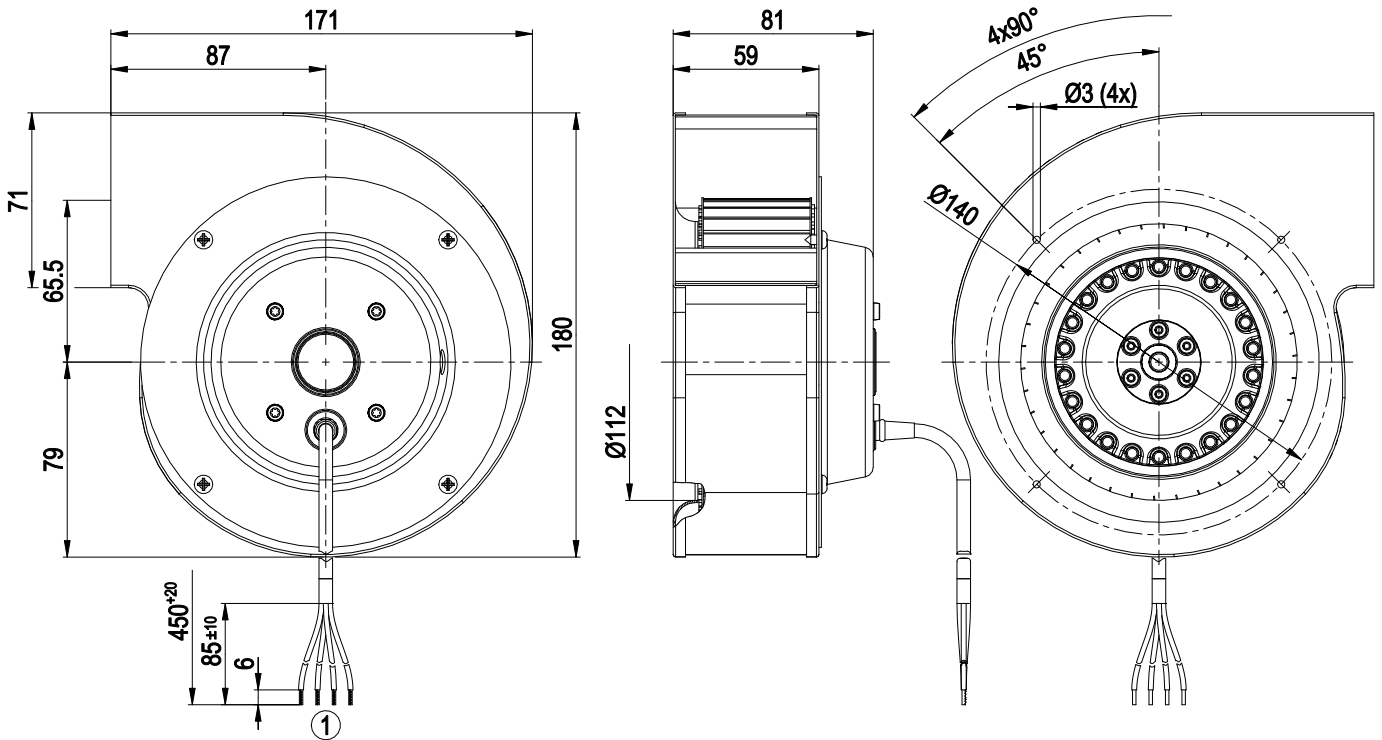

Cable PVC AWG20, 4x crimped splices

Connection diagram

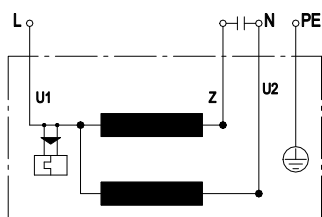

| | | | | | |
|----|--------------|---|-------|----|-------|
| U1 | blue | Z | brown | U2 | black |
| PE | green/yellow | | | | |



AC centrifugal fan

forward-curved, single-intake
with housing (without flange)

Curves: Air performance 50 Hz

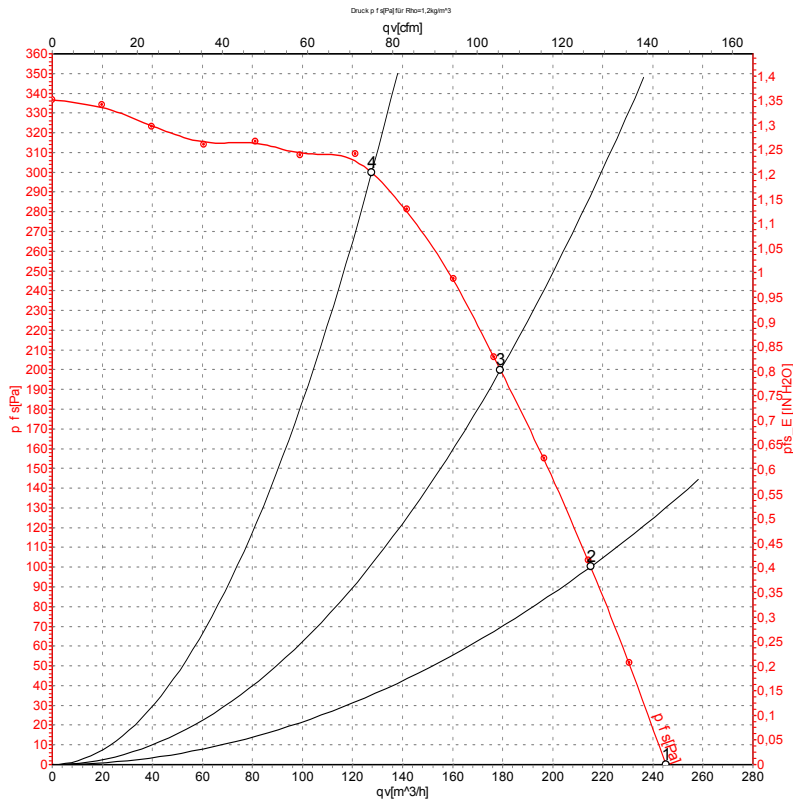

Measurement: LU-104594-1

Air performance measured according to ISO 5801 installation category A. For detailed information on the measurement setup, contact ebmpapst. Intake sound level: Sound power level according to ISO 13347 / sound pressure level measured at 1 m distance from fan axis. The values given are valid under the specified measuring conditions and may vary due to conditions of installation. For deviations from the standard configuration, the parameters have to be checked on the installed unit.

Measured values

| | U | f | n | P _e | I | q _v | p _{fs} | q _v | p _{fs} |
|---|-----|----|-------------------|----------------|------|-------------------|-----------------|----------------|-----------------|
| | V | Hz | min ⁻¹ | W | A | m ³ /h | Pa | cfm | inH2O |
| 1 | 230 | 50 | 2150 | 88 | 0.39 | 245 | 0 | 145 | 0.00 |
| 2 | 230 | 50 | 2325 | 79 | 0.35 | 215 | 100 | 125 | 0.40 |
| 3 | 230 | 50 | 2460 | 74 | 0.33 | 180 | 200 | 105 | 0.80 |
| 4 | 230 | 50 | 2610 | 68 | 0.31 | 130 | 300 | 75 | 1.20 |

U = Power supply · f = Frequency · n = Speed (rpm) · P_e = Power consumption · I = Current draw · q_v = Air flow · p_{fs} = Pressure increase



AC centrifugal fan

forward-curved, single-intake
with housing (without flange)

Curves: Air performance 60 Hz

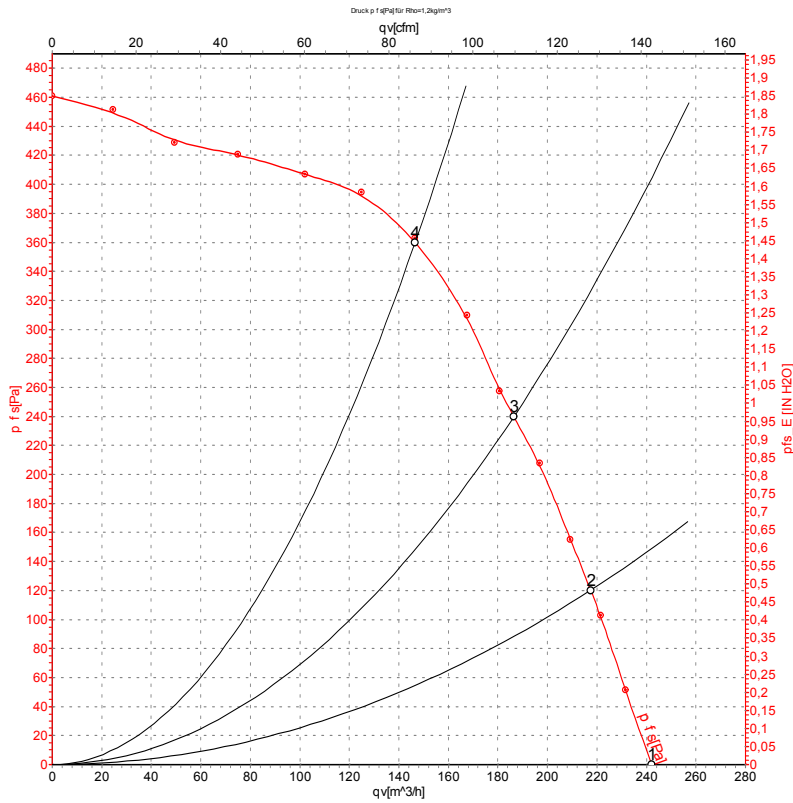

Measurement: LU-104597-1

Air performance measured according to ISO 5801 installation category A. For detailed information on the measurement setup, contact ebmpapst. Intake sound level: Sound power level according to ISO 13347 / sound pressure level measured at 1 m distance from fan axis. The values given are valid under the specified measuring conditions and may vary due to conditions of installation. For deviations from the standard configuration, the parameters have to be checked on the installed unit.

Measured values

| | U | f | n | P _e | I | q _V | P _{fs} | q _V | P _{fs} |
|---|-----|----|-------------------|----------------|------|-------------------|-----------------|----------------|--------------------|
| | V | Hz | min ⁻¹ | W | A | m ³ /h | Pa | cfm | inH ₂ O |
| 1 | 230 | 60 | 2100 | 110 | 0.49 | 240 | 0 | 140 | 0.00 |
| 2 | 230 | 60 | 2400 | 99 | 0.43 | 220 | 120 | 130 | 0.48 |
| 3 | 230 | 60 | 2635 | 94 | 0.41 | 185 | 240 | 110 | 0.96 |
| 4 | 230 | 60 | 2875 | 88 | 0.38 | 145 | 360 | 85 | 1.45 |

U = Power supply · f = Frequency · n = Speed (rpm) · P_e = Power consumption · I = Current draw · q_V = Air flow · p_{fs} = Pressure increase

