

G1G170-AB31-53

EC centrifugal fan

backward curved, single inlet

with housing (flange), Gas blower for gas-condensing heating



G1G170-AB31-53 ebmpapst Datasheet

sales@fansco.com

www.fansco.com

Limited partnership · Headquarters Muldingen
County court Stuttgart · HRA 590344

General partner Elektrobau Muldingen GmbH · Headquarters Muldingen
County court Stuttgart · HRB 590142



Nominal data

Type	G1G170-AB31-53	
Motor	M1G074-CF	
Phase		1~
Nominal voltage	VAC	230
Frequency	Hz	50
Type of data definition		ml
Speed (rpm)	min ⁻¹	6530
Power input	W	410
Current draw	A	1.8
Min. ambient temperature	°C	-25
Max. ambient temperature	°C	50
Min. temp. of flow medium	°C	-25
Max. temp. of flow medium	°C	80

ml = Max. load · me = Max. efficiency · fa = Running at free air · cs = Customer specs · cu = Customer unit
Subject to alterations

Data according to ErP directive

		Actual	Request 2015			
01 Overall efficiency η_{es}	%	57.1	46.4	09 Power input P_{ed}	kW	0.41
02 Measurement category		A		09 Air flow q_v	m ³ /h	380
03 Efficiency category		Static		09 Pressure increase p_{fs}	Pa	2001
04 Efficiency grade N		71.7	61	10 Speed (rpm) n	min ⁻¹	6530
05 Variable speed drive		Yes		11 Specific ratio*		1.02

Data definition with optimum efficiency.
The ErP data is determined using a motor-impeller combination in a standardised measurement configuration.

* Specific ratio = $1 + p_{fs} / 100\,000\text{ Pa}$

LU-56469



EC centrifugal fan

backward curved, single inlet

with housing (flange), Gas blower for gas-condensing heating

Technical features

Mass	4.7 kg
Size	170 mm
Surface of rotor	Coated in black
Material of protective cover	Polyflam RPP 374-ND CS1 (UL 97-V0)
Material of impeller	Aluminium sheet
Housing material	Die-cast aluminium
Direction of rotation	Clockwise, seen on rotor
Type of protection	IP 20
Insulation class	"B"
Humidity (F)/environmental protection class (H)	F2-1
Max. permissible ambient motor temp. (transp./ storage)	+ 80 °C
Min. permissible ambient motor temp. (transp./storage)	- 40 °C
Mounting position	Any
Condensate discharge holes	None
Cooling bore / aperture	Rotor-side
Premix	If gas is premixed in the blower, a special blower must be used.
Motor bearing	Ball bearing
Technical features	- Tach output - Motor current limit - Control input PWM
Touch current acc. IEC 60990 (measuring network Fig. 4, TN system)	<= 3.5 mA
Electrical leads	With plug
Motor protection	Thermal overload protector (TOP) wired internally
Approval	CSA C22.2 No.113; UL 507



EC centrifugal fan

backward curved, single inlet

with housing (flange), Gas blower for gas-condensing heating

Product drawing

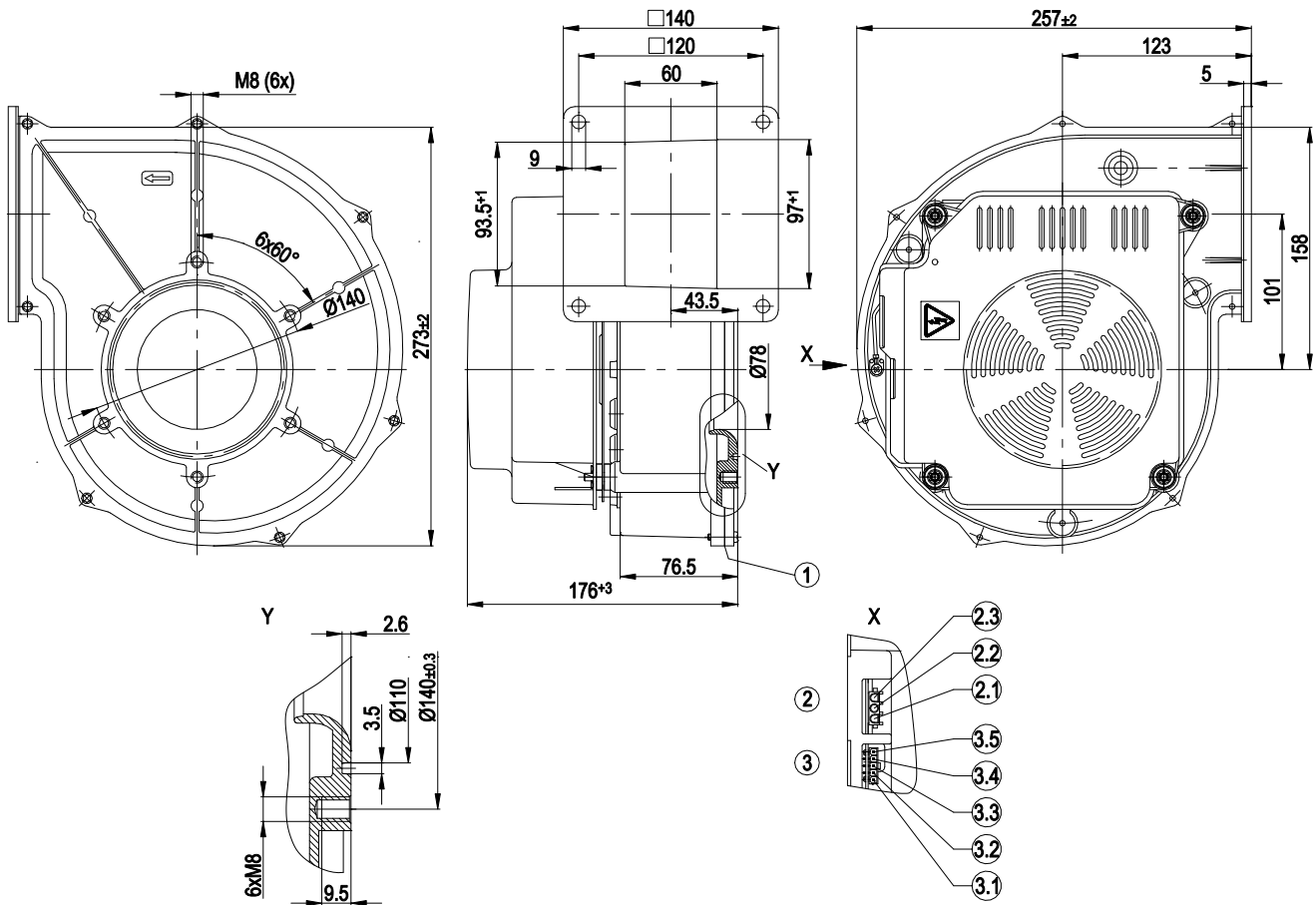

1	Housing side parts sealed with NBR round cord (pentane-resistant)
2	3-pole strip, mating connector: (not included in standard scope of delivery): tyco No. 350 766-1; female terminal: tyco No. 926 884-1
2.1	L
2.2	N
2.3	PE
3	5-pole strip; mating connector (not included in delivery) Molex No. 39-01-4050, female connector Molex No. 39-00-0059
3.1	(+)
3.2	Speed monitoring
3.3	Not assigned
3.4	PWM input
3.5	(-)



EC centrifugal fan

backward curved, single inlet

with housing (flange), Gas blower for gas-condensing heating

Connection screen

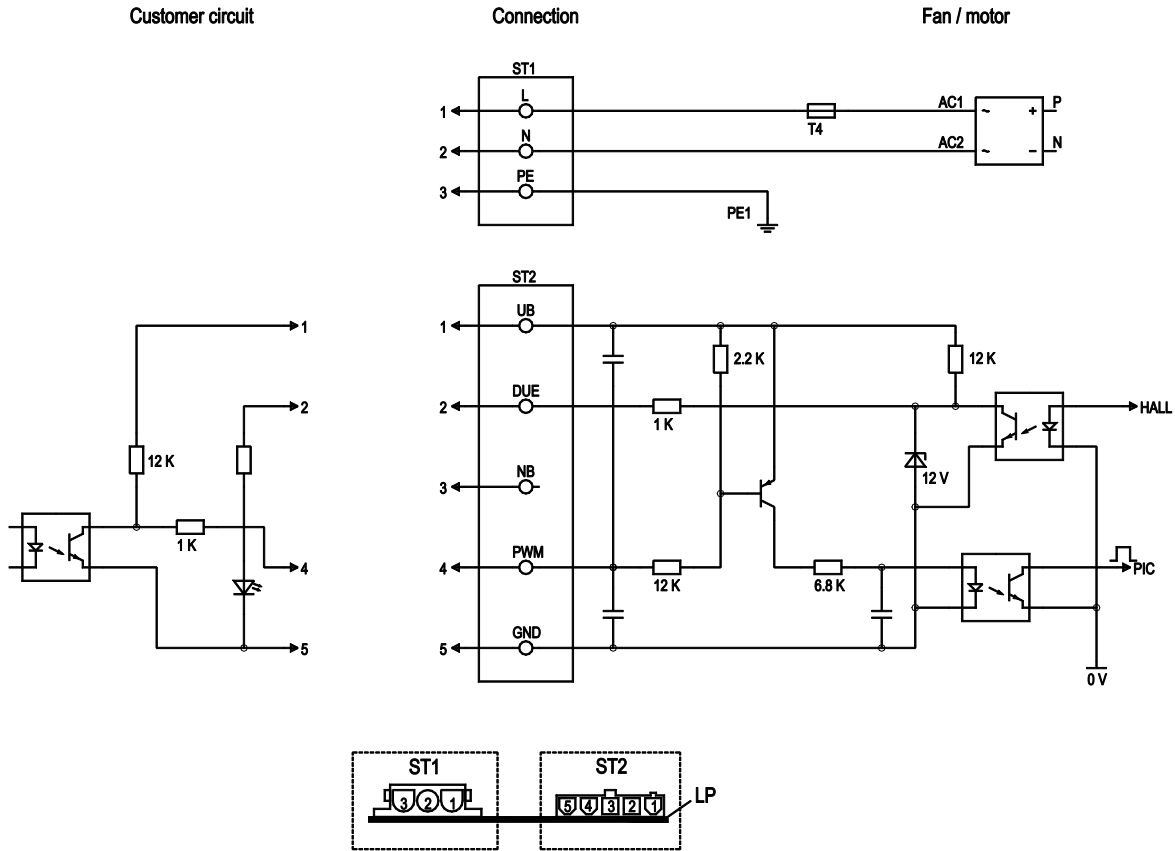

No.	Conn.	Designation	Function / assignment
ST1	1,2,3	L, N, PE	Power supply 230 VAC, 50-60 Hz, neutral conductor, protective earth
ST2	1	UB	External voltage 18-43 VDC
ST2	2	Tach	Speed monitoring output connection, monitoring circuit output, 3 pulses per revolution, current source 2 mA
ST2	3	N.C.	Not assigned
ST2	4	PWM	PWM - 2 - 6 kHz control input, PWM on n = 100%, PWM low n = 0%
ST2	5	GND	GND - Connection for control interface



EC centrifugal fan

backward curved, single inlet

with housing (flange), Gas blower for gas-condensing heating

Charts: Air flow 50 Hz

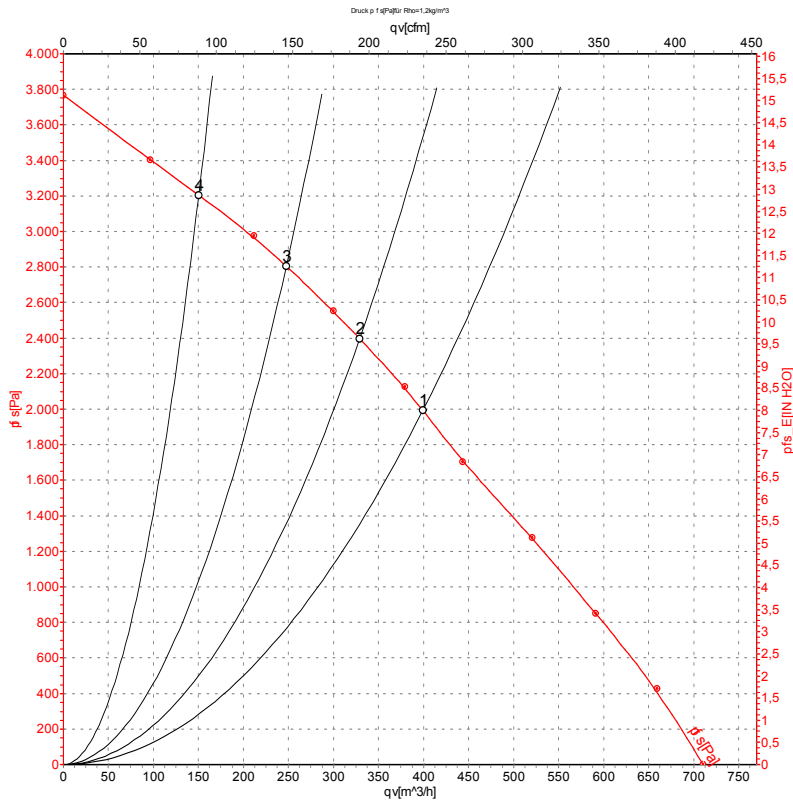

Measurement: LU-56469-1

Air performance measured as per ISO 5801 Installation category A. For detailed information on the measuring set-up, please contact ebmpapst. Suction-side noise levels: L_{wA} measured as per ISO 13347 / L_{pA} measured with 1m distance to fan axis. The values given are valid under the measuring conditions mentioned above and may vary according to the actual installation situation. With any deviation from the standard set-up, the specific values have to be checked and reviewed with the unit installed.

Measured values

	U	f	n	P _{ed}	I	qv	p _{fs}	qv	p _{fs}
	V	Hz	min ⁻¹	W	A	m ³ /h	Pa	CFM	inH ₂ O
1	230	50	6530	410	1.80	380	2000	225	8.03
2	230	50	6665	400	1.75	330	2400	195	9.64
3	230	50	6915	370	1.62	250	2800	145	11.24
4	230	50	7250	326	1.44	150	3200	90	12.85

U = Supply voltage · f = Frequency · n = Speed (rpm) · P_{ed} = Power input · I = Current draw · qv = Air flow · p_{fs} = Pressure increase

