

EC centrifugal fan

forward curved, single inlet

with housing (flange), Gas blower for gas-condensing heating

G1G170-AB31-36 ebmpapst Datasheet

sales@fansco.com

www.fansco.com

Limited partnership · Headquarters Muldingen
County court Stuttgart · HRA 590344

General partner Elektrobau Muldingen GmbH · Headquarters Muldingen
County court Stuttgart · HRB 590142



Nominal data

Type	G1G170-AB31-36	
Motor	M1G074-CF	
Phase		1~
Nominal voltage	VAC	230
Frequency	Hz	50
State		prelim.
Speed	min ⁻¹	6530
Power input	W	410
Current draw	A	1.8
Min. ambient temperature	°C	-25
Max. ambient temperature	°C	50

ml = max. load · me = max. efficiency · fa = running at free air · cs = customer specs · cu = customer unit
Subject to alterations

Data according to ErP directive

Installation category	A
Efficiency category	Static
Variable speed drive	Yes
Specific ratio*	1.02

* Specific ratio = $1 + p_{fs} / 100\,000\text{ Pa}$

		Actual	Request 2013	Request 2015
Overall efficiency η_{es}		57.1	43.4	46.4
Efficiency grade N		71.7	58	61
Power input P_{ed}	kW	0.41		
Air flow q_v	m ³ /h	380		
Pressure increase p_{fs}	Pa	2001		
Speed n	min ⁻¹	6530		

Data established at point of optimum efficiency



EC centrifugal fan

forward curved, single inlet

with housing (flange), Gas blower for gas-condensing heating

Technical features

Mass	4.6 kg
Size	170 mm
Surface of rotor	Coated in black
Material of impeller	Aluminium sheet
Housing material	Die-cast aluminium
Motor suspension	Motor anti-vibration mounted on one side via mounting plate
Direction of rotation	Clockwise, seen on rotor
Type of protection	IP 20; Depending on installation and position
Insulation class	"B"
Max. permissible ambient motor temp. (transp./ storage)	+ 80 °C
Min. permissible ambient motor temp. (transp./storage)	- 40 °C
Mounting position	Shaft horizontal or rotor on bottom; rotor on top on request
Condensate discharge holes	Rotor-side
Cooling bore / aperture	Rotor-side
Operation mode	S1
Motor bearing	Ball bearing
Technical features	<ul style="list-style-type: none"> - Tach output - Motor current limit - Emergency operation - PFC, active - PWM control input - Control interface with SELV potential safely disconnected from the mains - Over-temperature protected motor
EMC interference immunity	Acc. to EN 61000-6-2 (industrial environment)
EMC harmonics	Acc. to EN 61000-3-2/3
EMC interference emission	Acc. to EN 61000-6-4 (industrial environment)
Touch current acc. IEC 60990 (measuring network Fig. 4, TN system)	<= 3.5 mA
Electrical leads	With plug
Motor protection	Thermal overload protector (TOP) wired internally
Protection class	I (if protective earth is connected by customer)
Product conforming to standard	EN 60335-1
Approval	UL 507; CSA C22.2 Nr.113



EC centrifugal fan

forward curved, single inlet

with housing (flange), Gas blower for gas-condensing heating

Product drawing

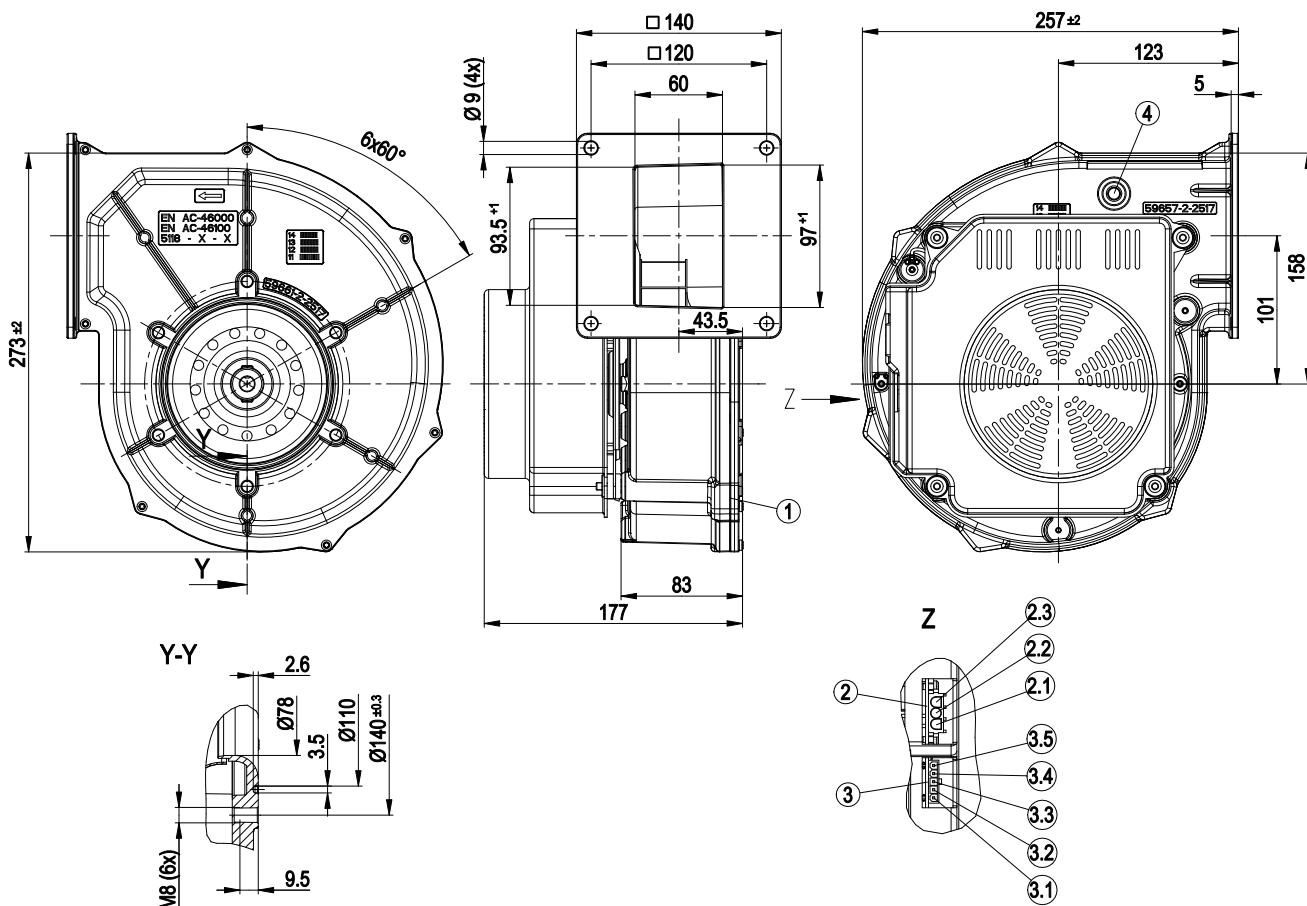

1	Housing side parts sealed with NBR round cord (pentane-resistant)
2	3-pole strip, mating connector (not included in standard scope of delivery): tyco No. 350 766-1; female terminal: tyco No. 926 884-1
2.1	L
2.2	N
2.3	PE
3	5-pole strip; mating connector (not included in standard scope of delivery) Molex No. 39-01-4050, female terminal Molex No. 39-00-0059
3.1	(+)
3.2	Speed monitoring
3.3	Not assigned
3.4	PWM input
3.5	(-)
4	Bleeder connection for pressure relief possible



EC centrifugal fan

forward curved, single inlet

with housing (flange), Gas blower for gas-condensing heating

Connection screen

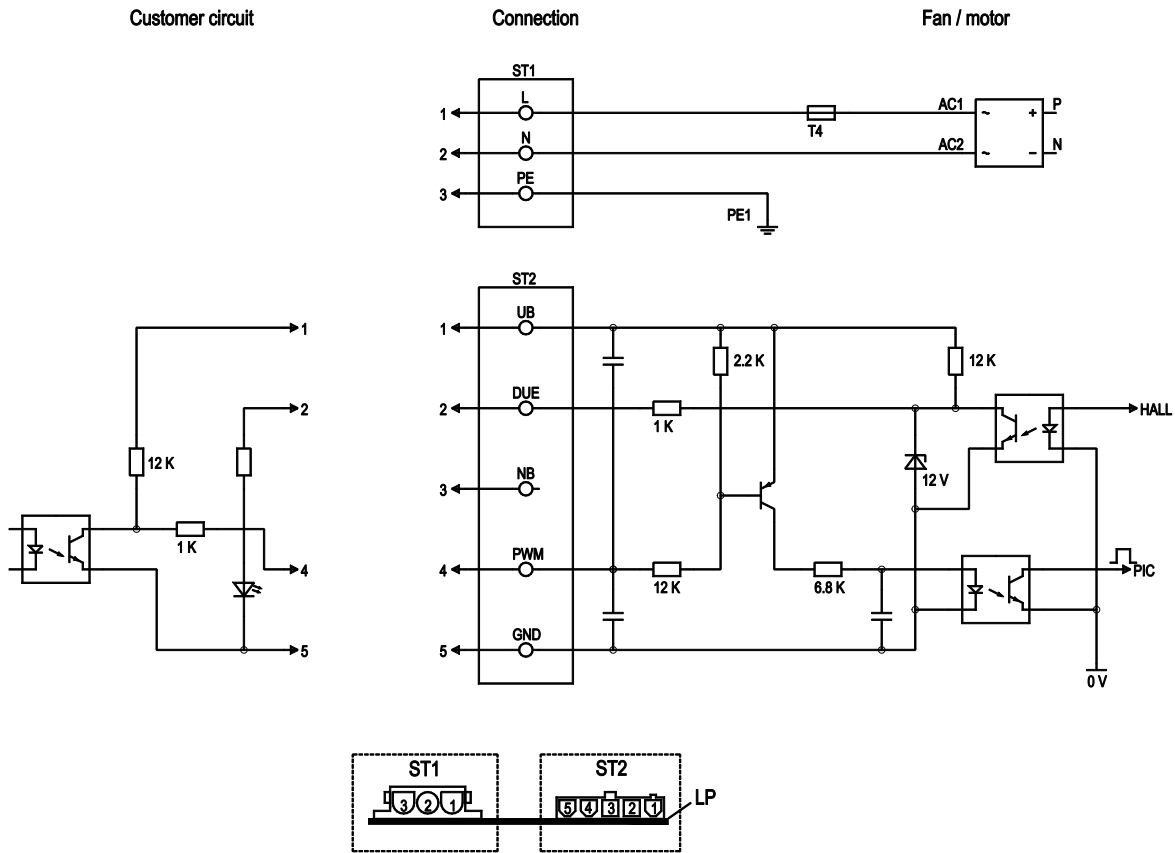

No.	Pin	Signal	Function / assignment
ST1	1,2,3	L, N, PE	Power supply 230 VAC, 50-60 Hz, neutral conductor, protective earth
ST2	1	UB	External voltage 18-43 VDC
ST2	2	Tach	Speed monitoring output connection, monitoring circuit output, 3 pulses per revolution, current source 2 mA
ST2	3	N.C.	Not assigned
ST2	4	PWM	PWM - 2 - 6 kHz control input, PWM on n = 100%, PWM low n = 0%
ST2	5	GND	GND - Connection for control interface



EC centrifugal fan

forward curved, single inlet

with housing (flange), Gas blower for gas-condensing heating

Charts: Air flow 50 Hz

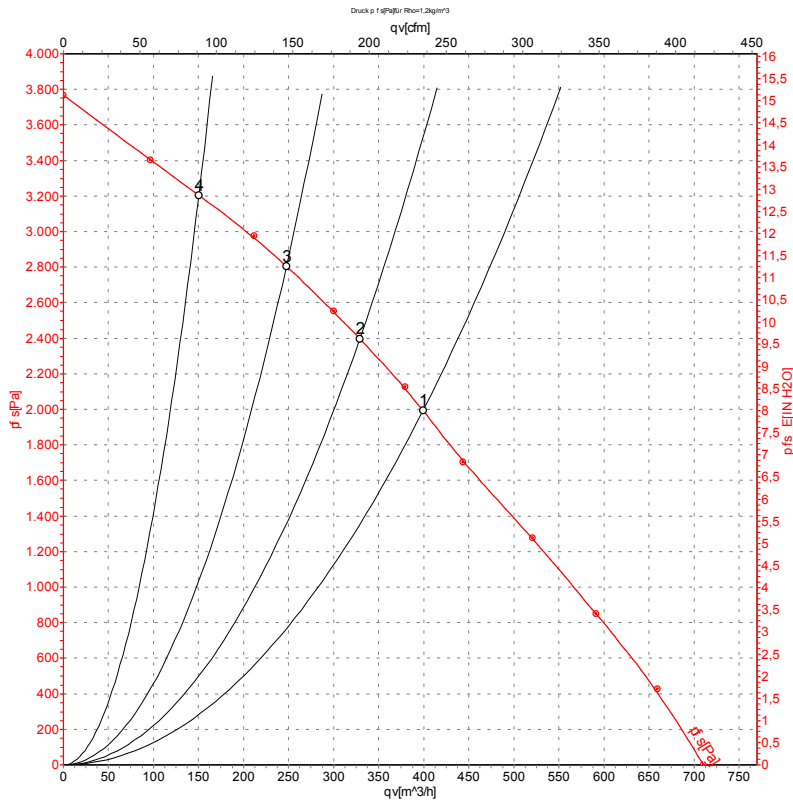

Measurement: LU-56469

Air performance measured as per ISO 5801 Installation category A. For detailed information on the measuring set-up, please contact ebm-papst. Suction-side noise levels: L_{wA} measured as per ISO 13347 / L_{pA} measured with 1m distance to fan axis. The values given are valid under the measuring conditions mentioned above and may vary according to the actual installation situation. With any deviation from the standard set-up, the specific values have to be checked and reviewed with the unit installed.

Measured values

	U	f	n	P _{ed}	I	qv	P _{fs}
	V	Hz	min ⁻¹	W	A	m ³ /h	Pa
1	230	50	6530	410	1.80	380	2000
2	230	50	6665	400	1.75	330	2400
3	230	50	6915	370	1.62	250	2800
4	230	50	7250	326	1.44	150	3200

U = Supply voltage · f = Frequency · n = Speed · P_{ed} = Power input · I = Current draw · qv = Air flow · p_{fs} = Pressure increase

