

G1G170-AB31-22

# EC centrifugal fan

backward curved, single inlet

with housing (flange), Gas blower for gas-condensing heating



G1G170-AB31-22 ebmpapst Datasheet

sales@fansco.com

www.fansco.com

Limited partnership · Headquarters Muldingen  
County court Stuttgart · HRA 590344

General partner Elektrobau Muldingen GmbH · Headquarters Muldingen  
County court Stuttgart · HRB 590142



## Nominal data

Type	G1G170-AB31-22	
Motor	M1G074-CF	
Phase		1~
Nominal voltage	VAC	230
Frequency	Hz	50/60
Type of data definition		fa
Speed	min <sup>-1</sup>	5650
Power input	W	315
Current draw	A	2.15
Min. ambient temperature	°C	-25
Max. ambient temperature	°C	55
Min. temp. of flow medium	°C	-25
Max. temp. of flow medium	°C	+80

ml = max. load · me = max. efficiency · fa = running at free air · cs = customer specs · cu = customer unit  
Subject to alterations

## Data according to ErP directive

Installation category	A
Efficiency category	Static
Variable speed drive	Yes
Specific ratio*	1.02

\* Specific ratio =  $1 + p_{fs} / 100\,000\text{ Pa}$

	Actual	Request 2013	Request 2015
Overall efficiency $\eta_{es}$	61.3	41.9	44.9
Efficiency grade N	77.4	58	61
Power input $P_{ed}$	kW	0.29	
Air flow $q_v$	m <sup>3</sup> /h	370	
Pressure increase $p_{fs}$	Pa	1601	
Speed n	min <sup>-1</sup>	5960	

Data established at point of optimum efficiency



# EC centrifugal fan

backward curved, single inlet

with housing (flange), Gas blower for gas-condensing heating

## Technical features

<b>Mass</b>	4.5 kg
<b>Size</b>	170 mm
<b>Surface of rotor</b>	Coated in black
<b>Material of protective cover</b>	Polyflam RPP 374-ND CS1 (UL 97-V0)
<b>Material of impeller</b>	Aluminium sheet
<b>Housing material</b>	Die-cast aluminium
<b>Direction of rotation</b>	Clockwise, seen on rotor
<b>Type of protection</b>	IP 20
<b>Insulation class</b>	"B"
<b>Max. permissible ambient motor temp. (transp./ storage)</b>	+80 °C
<b>Min. permissible ambient motor temp. (transp./storage)</b>	-40 °C
<b>Mounting position</b>	Any
<b>Condensate discharge holes</b>	Rotor-side
<b>Cooling bore / aperture</b>	Rotor-side
<b>Operation mode</b>	S1
<b>Motor bearing</b>	Ball bearing
<b>Technical features</b>	<ul style="list-style-type: none"> <li>- Tach output</li> <li>- Motor current limit</li> <li>- PWM control input</li> <li>- Over-temperature protected motor</li> </ul>
<b>EMC interference immunity</b>	Acc. to EN 61000-6-2 (industrial environment)
<b>EMC interference emission</b>	Acc. to EN 61000-6-3 (household environment)
<b>Touch current acc. IEC 60990 (measuring network Fig. 4, TN system)</b>	<= 3.5 mA
<b>Electrical leads</b>	With plug
<b>Motor protection</b>	Thermal overload protector (TOP) wired internally
<b>Product conforming to standard</b>	CE
<b>Approval</b>	VDE; UL 507; CSA C22.2 Nr.113



# EC centrifugal fan

backward curved, single inlet

with housing (flange), Gas blower for gas-condensing heating

## Product drawing

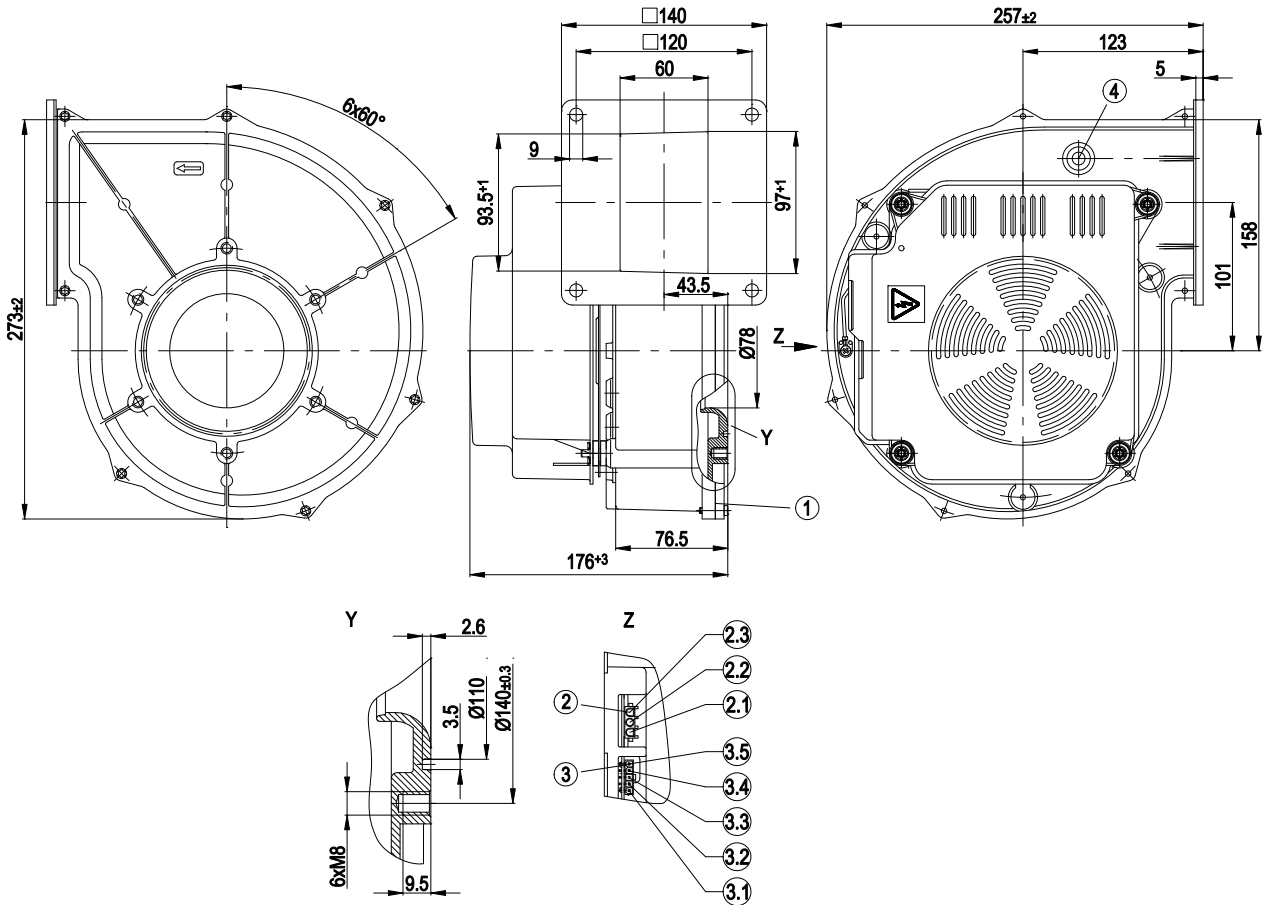

1	Housing side parts sealed with NBR round cord (pentane-resistant)
2	3-pole strip; mating connector (not included in delivery): tyco No. 350 766-1; female connector: No. 926 884-1
2.1	L
2.2	N
2.3	PE
3	5-pole strip; mating connector (not included in delivery) Molex No. 39-01-4050, female connector Molex No. 39-00-0059
3.1	(+)
3.2	Speed monitoring
3.3	Not assigned
3.4	PWM input
3.5	(-)
4	Bleeder connection for pressure relief possible



# EC centrifugal fan

backward curved, single inlet  
with housing (flange), Gas blower for gas-condensing heating

## Connection screen

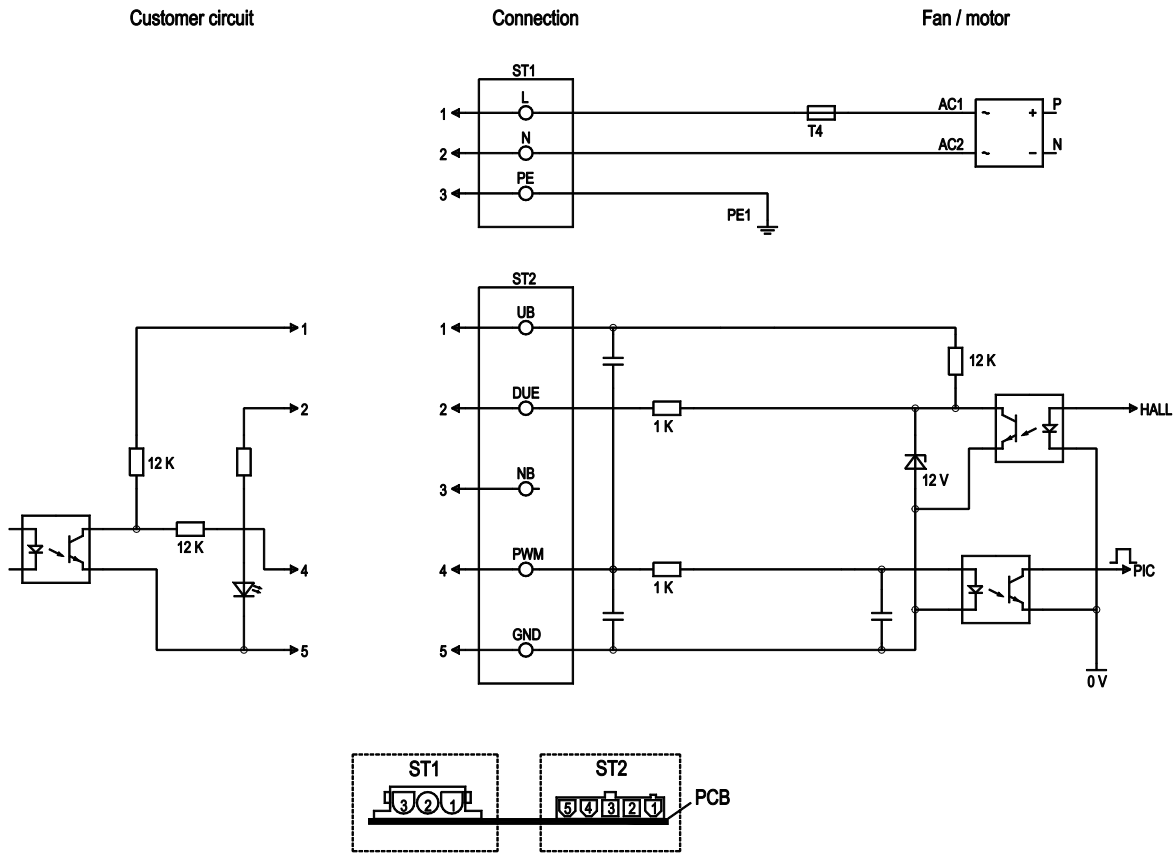

No.	Pin	Signal	Function / assignment
ST1	1, 2, 3	L, N, PE	Power supply 230 VAC, 50-60 Hz, neutral conductor, protective earth
ST2	1	UB	External voltage 24-45 VDC
ST2	2	Tach	Speed monitoring output connection, monitoring circuit output, 3 pulses per revolution, current source 1 mA
ST2	3	N.C.	Not assigned
ST2	4	PWM	PWM - 2 - 6 kHz control input, PWM on n = 100%, PWM low n = 0%
ST2	5	GND	GND - Connection for control interface



# EC centrifugal fan

backward curved, single inlet

with housing (flange), Gas blower for gas-condensing heating

## Charts: Air flow 50 Hz

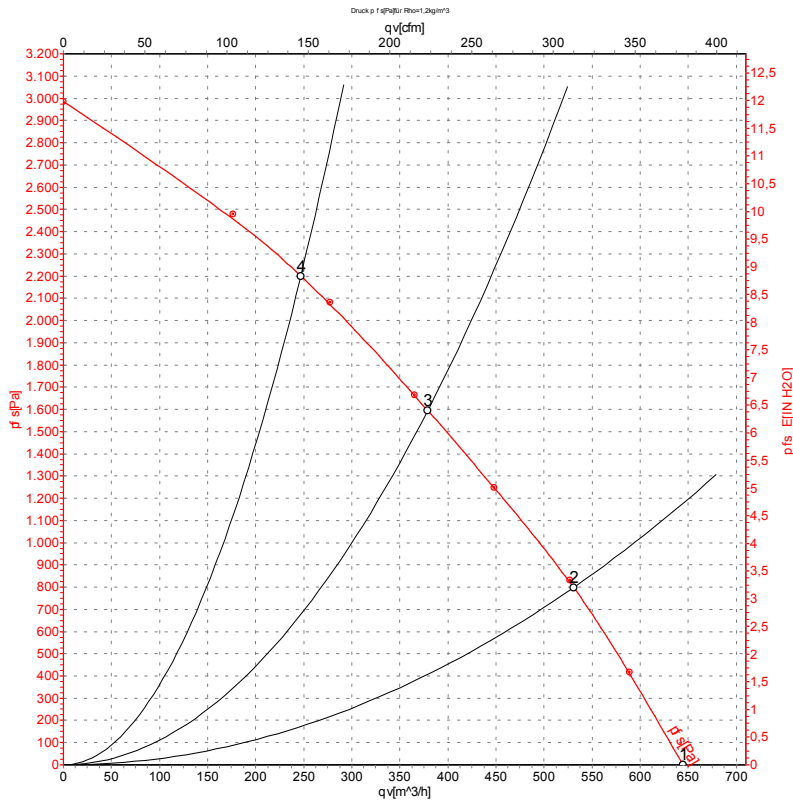

Measurement: LU-48240

Air performance measured as per ISO 5801 Installation category A. For detailed information on the measuring set-up, please contact ebm-papst. Suction-side noise levels: L<sub>wA</sub> measured as per ISO 13347 / L<sub>pA</sub> measured with 1m distance to fan axis. The values given are valid under the measuring conditions mentioned above and may vary according to the actual installation situation. With any deviation from the standard set-up, the specific values have to be checked and reviewed with the unit installed.

## Measured values

	U	f	n	P <sub>ed</sub>	I	qv	P <sub>fs</sub>
	V	Hz	min <sup>-1</sup>	W	A	m <sup>3</sup> /h	Pa
1	230	50	5650	315	2.15	645	0
2	230	50	5740	315	2.15	530	800
3	230	50	5940	300	2.08	380	1600
4	230	50	6215	273	1.88	245	2200

U = Supply voltage · f = Frequency · n = Speed · P<sub>ed</sub> = Power input · I = Current draw · qv = Air flow · p<sub>fs</sub> = Pressure increase

