

G1G170-AB05-49

EC centrifugal fan

forward curved, single inlet

with housing (flange), Gas blower for gas-condensing heating



G1G170-AB05-49 ebmpapst Datasheet

sales@fansco.com

www.fansco.com

Limited partnership · Headquarters Mulfingen
County court Stuttgart · HRA 590344

General partner Elektrobau Mulfingen GmbH · Headquarters Mulfingen
County court Stuttgart · HRB 590142

Nominal data

Type	G1G170-AB05-49	
Motor	M1G074-CF	
Phase		1~
Nominal voltage	VAC	115
Frequency	Hz	50/60
Type of data definition		fa
Speed	min ⁻¹	5730
Power input	W	345
Current draw	A	4.0
Min. ambient temperature	°C	- 25
Max. ambient temperature	°C	+ 55
Min. temp. of flow medium	°C	-25
Max. temp. of flow medium	°C	+80

ml = max. load · me = max. efficiency · fa = running at free air · cs = customer specs · cu = customer unit
Subject to alterations



EC centrifugal fan

forward curved, single inlet

with housing (flange), Gas blower for gas-condensing heating

Technical features

Mass	4.6 kg
Size	170 mm
Material of impeller	Aluminium sheet
Housing material	Die-cast aluminium
Motor suspension	Motor anti-vibration mounted on one side via mounting plate
Direction of rotation	Clockwise, seen on rotor
Type of protection	IP 20; Depending on installation and position
Insulation class	"B"
Max. permissible ambient motor temp. (transp./ storage)	+ 80 °C
Min. permissible ambient motor temp. (transp./storage)	- 40 °C
Mounting position	Shaft horizontal or rotor on bottom; rotor on top on request
Condensate discharge holes	Rotor-side
Cooling bore / aperture	Rotor-side
Operation mode	S1
Motor bearing	Ball bearings made of stainless steel
Technical features	<ul style="list-style-type: none"> - Tach output - Motor current limit - Emergency operation - PWM control input - Control interface with SELV potential safely disconnected from the mains - Over-temperature protected motor
Touch current acc. IEC 60990 (measuring network Fig. 4, TN system)	<= 3.5 mA
Electrical leads	With plug
Motor protection	Thermal overload protector (TOP) wired internally
Protection class	I (if protective earth is connected by customer)
Product conforming to standard	EN 60335-1
Approval	UL 507; CSA C22.2 Nr.113



EC centrifugal fan

forward curved, single inlet

with housing (flange), Gas blower for gas-condensing heating

Product drawing

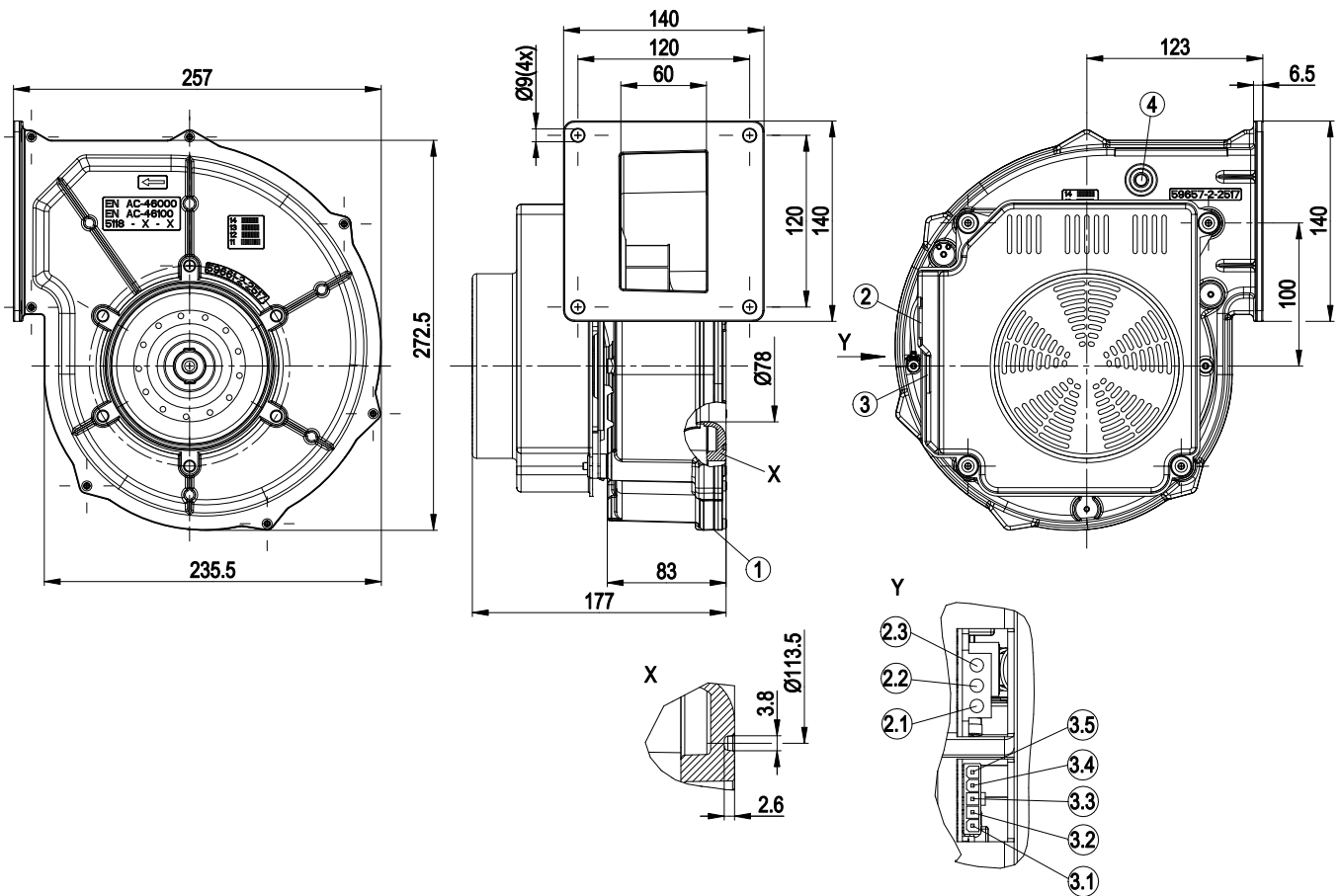

1	Housing side parts sealed with NBR round cord (pentane-resistant)
2	3-pole strip, mating connector (not included in standard scope of delivery): tyco No. 350 766-1; female terminal: tyco No. 926 884-1
2.1	L
2.2	N
2.3	PE
3	5-pole strip; mating connector (not included in standard scope of delivery) Molex No. 39-01-4050, female connector Molex No. 39-00-0059
3.1	UB
3.2	DUE
3.3	not assigned (NB)
3.4	PWM input
3.5	GND (-)
4	Bleeder connection for pressure relief possible



EC centrifugal fan

forward curved, single inlet

with housing (flange), Gas blower for gas-condensing heating

Connection screen

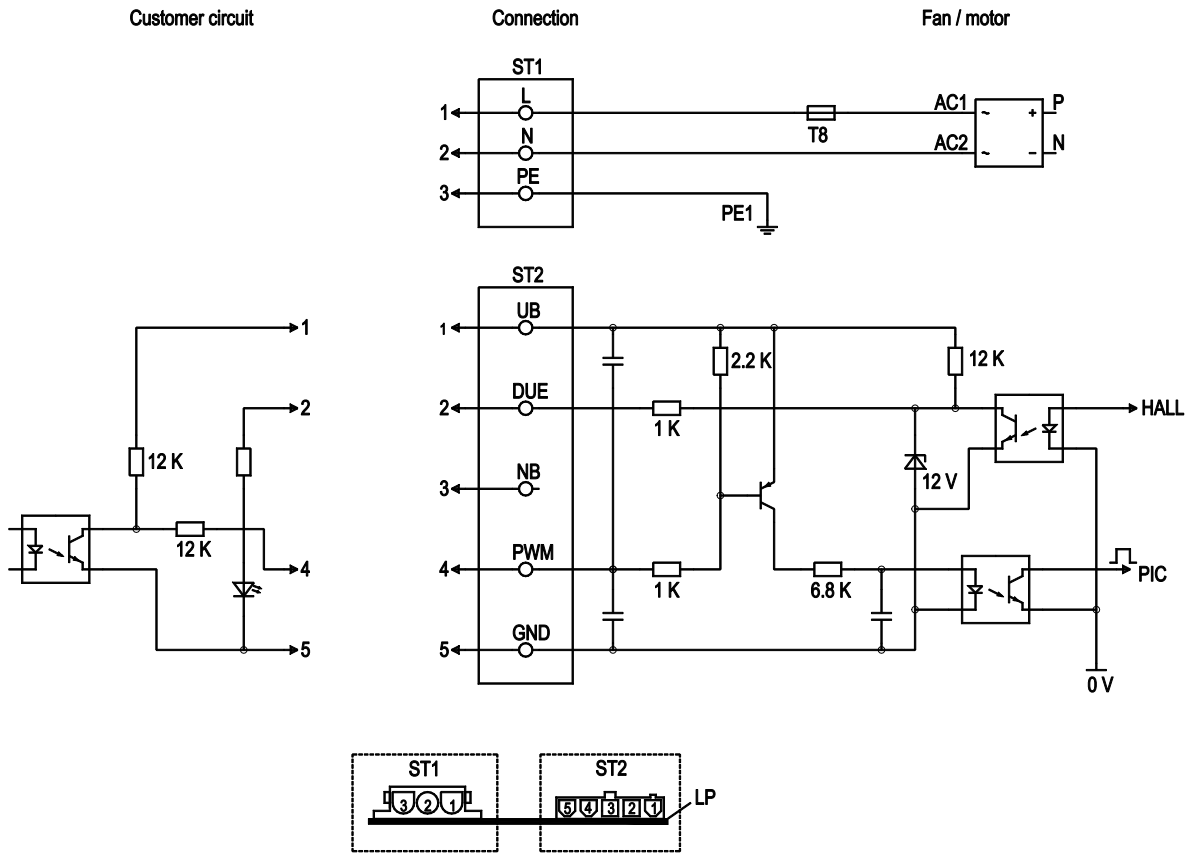

No.	Pin	Signal	Function / assignment
ST1	1, 2, 3	L, N, PE	Power supply 115 VAC, 50-60 Hz, neutral conductor, protective earth
ST2	1	UB	External voltage 24-45 VDC
ST2	2	Tach	Speed monitoring output connection, monitoring circuit output, 3 pulses per revolution, current source 1 mA
ST2	3	N.C.	Not assigned
ST2	4	PWM	PWM - 2-6 kHz control input, PWM on n = 100%, PWM low n = 0%
ST2	5	GND	GND - Connection for control interface



EC centrifugal fan

forward curved, single inlet

with housing (flange), Gas blower for gas-condensing heating

Charts: Air flow 50 Hz

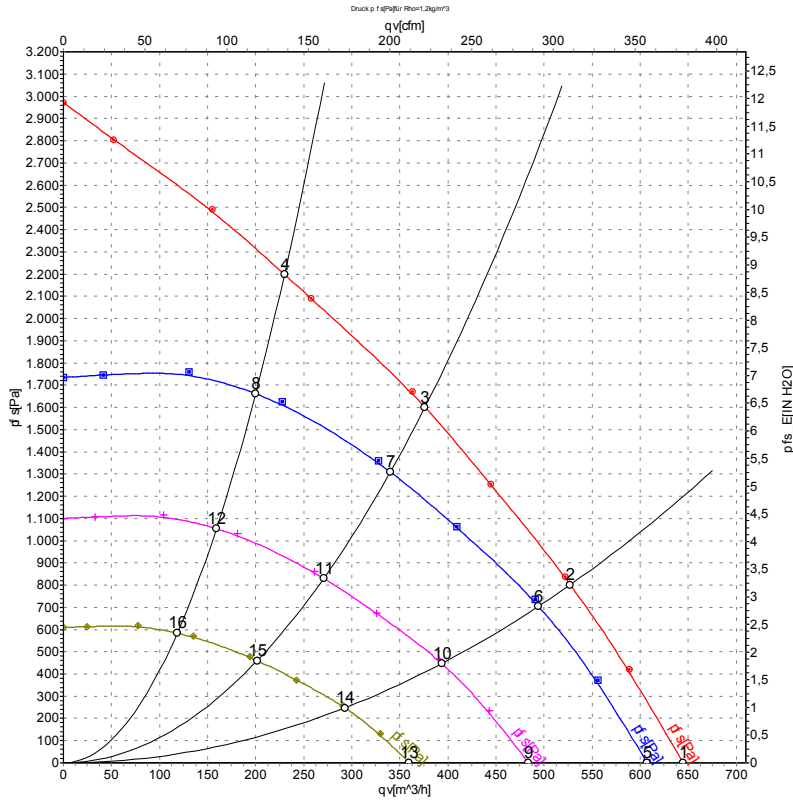

Measurement: LU-48962

Air performance measured as per ISO 5801 Installation category A. For detailed information on the measuring set-up, please contact ebmpapst. Suction-side noise levels: LwA measured as per ISO 13347 / LpA measured with 1m distance to fan axis. The values given are valid under the measuring conditions mentioned above and may vary according to the actual installation situation. With any deviation from the standard set-up, the specific values have to be checked and reviewed with the unit installed.

Measured values

	U	f	n	P _{ed}	I	qv	P _{fs}
	V	Hz	min ⁻¹	W	A	m ³ /h	Pa
1	115	50	5730	345	4.00	645	0
2	115	50	5750	342	3.97	525	800
3	115	50	5970	317	3.70	375	1600
4	115	50	6205	292	3.42	230	2200
5	115	50	5400	288	3.33	605	0
6	115	50	5400	283	3.28	495	715
7	115	50	5400	235	2.75	340	1314
8	115	50	5400	193	2.26	200	1664
9	115	50	4300	145	1.68	485	0
10	115	50	4300	143	1.66	395	454
11	115	50	4300	119	1.39	270	834
12	115	50	4300	98	1.14	160	1055
13	115	50	3200	60	0.69	360	0
14	115	50	3200	59	0.68	295	251
15	115	50	3200	49	0.57	200	462
16	115	50	3200	40	0.47	120	584

U = Supply voltage · f = Frequency · n = Speed · P_{ed} = Power input · I = Current draw · qv = Air flow · p_{fs} = Pressure increase

