

AC centrifugal fan

forward curved, dual inlet
with housing (without flange)

D4E240-AA01-11 ebmpapst Datasheet
sales@fansco.com
www.fansco.com

Limited partnership · Headquarters Mulfingen
County court Stuttgart · HRA 590344

General partner Elektrobau Mulfingen GmbH · Headquarters Mulfingen
County court Stuttgart · HRB 590142

Nominal data

| | | |
|-------------------------------|-------------------|---------|
| Type | D4E240-AA01-11 | |
| Motor | M4E094-IF | |
| Phase | | 1~ |
| Nominal voltage | VAC | 230 |
| Frequency | Hz | 50 |
| Type of data definition | | ml |
| Valid for approval / standard | | CE |
| Speed (rpm) | min ⁻¹ | 1330 |
| Power input | W | 950 |
| Current draw | A | 4.15 |
| Motor capacitor | µF | 25 |
| Capacitor voltage | VDB | 400 |
| Capacitor standard | | S2 (CE) |
| Min. back pressure | Pa | 70 |
| Min. ambient temperature | °C | -25 |
| Max. ambient temperature | °C | 70 |

ml = Max. load · me = Max. efficiency · fa = Running at free air · cs = Customer specs · cu = Customer unit
Subject to alterations

Data according to ErP directive

| | | Actual | Request 2015 | | | |
|--------------------------------|---|--------|--------------|----------------------------|-------------------|------|
| 01 Overall efficiency η_e | % | 41.7 | 41.7 | 09 Power input P_e | kW | 0.7 |
| 02 Measurement category | | B | | 09 Air flow q_v | m ³ /h | 2405 |
| 03 Efficiency category | | Total | | 09 Pressure increase p_f | Pa | 428 |
| 04 Efficiency grade N | | 49 | 49 | 10 Speed (rpm) n | min ⁻¹ | 1390 |
| 05 Variable speed drive | | No | | 11 Specific ratio* | | 1.00 |

Data definition with optimum efficiency.
The ErP data is determined using a motor-impeller combination in a standardised measurement configuration.

* Specific ratio = $1 + p_f / 100\,000\text{ Pa}$

LU-155176



AC centrifugal fan

forward curved, dual inlet
with housing (without flange)

Technical features

| | |
|--|---|
| Mass | 14.0 kg |
| Size | 240 mm |
| Material of impeller | Sheet steel, galvanised |
| Housing material | Sheet steel, galvanised |
| Motor suspension | Motor mounted anti-vibration on both sides |
| Direction of rotation | Counter-clockwise, seen on rotor |
| Type of protection | IP 10 |
| Insulation class | "F" |
| Humidity (F)/environmental protection class (H) | H0 - dry environment |
| Max. permissible ambient motor temp. (transp./ storage) | +80 °C |
| Min. permissible ambient motor temp. (transp./storage) | -40 °C |
| Mounting position | Any |
| Condensate discharge holes | None |
| Operation mode | S1 |
| Motor bearing | Ball bearing |
| Touch current acc. IEC 60990 (measuring network Fig. 4, TN system) | <= 3.5 mA |
| Motor protection | Thermal overload protector (TOP) wired internally |
| Cable exit | Axial |
| Protection class | I (if protective earth is connected by customer) |
| Motor capacitor according to EN 60252-1 in safety protection class | S2 |
| Product conforming to standard | EN 60034-1 (2010); CE |



D4E240-AA01-11

AC centrifugal fan

forward curved, dual inlet
with housing (without flange)

Product drawing

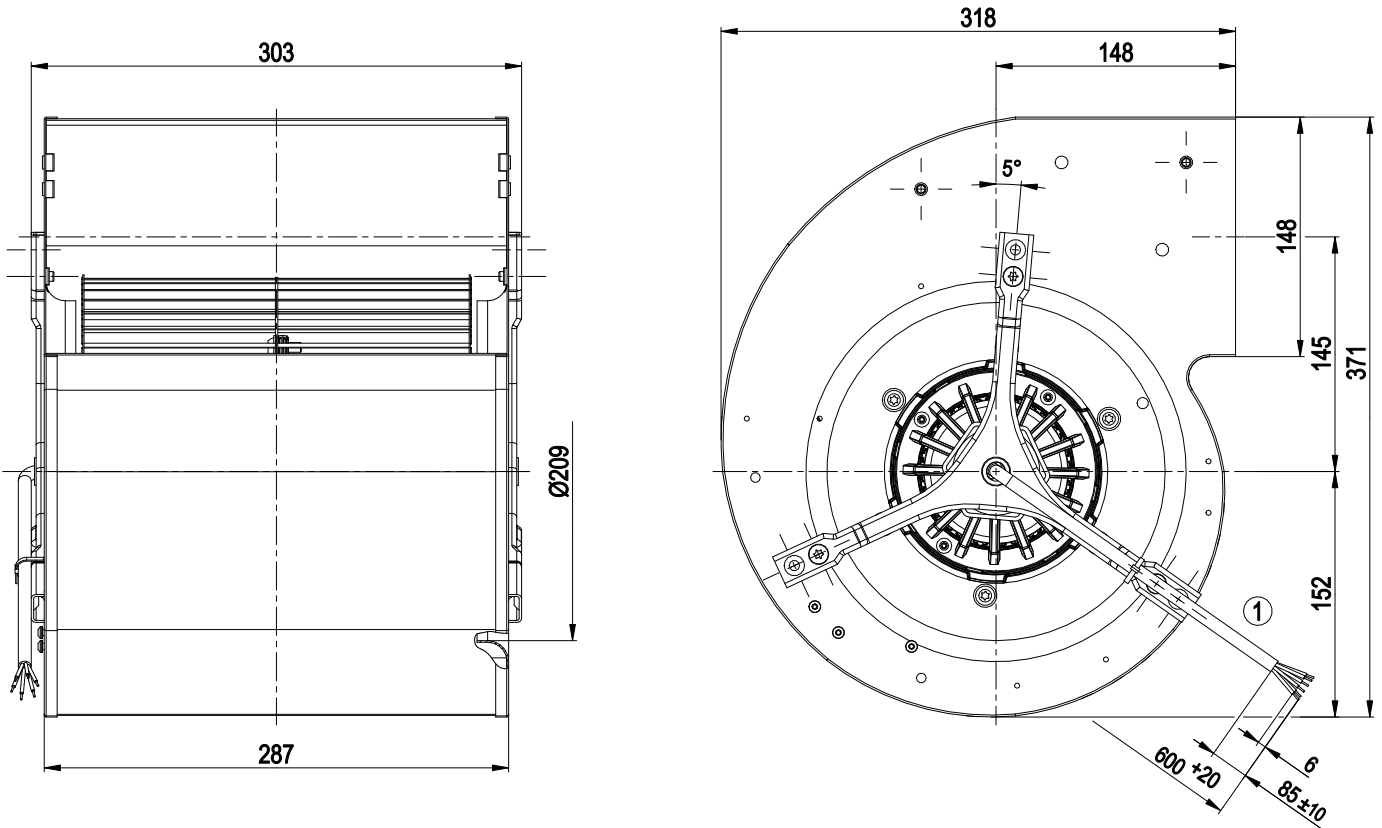

1 Connection line ETFE AWG18, 4x lead tips crimped

Connection screen

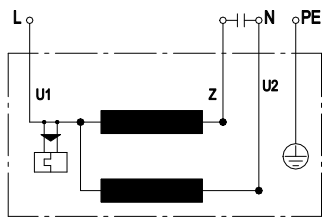

| | | | | | |
|----|--------------|---|-------|----|-------|
| U1 | blue | Z | brown | U2 | black |
| PE | green/yellow | | | | |



AC centrifugal fan

forward curved, dual inlet
with housing (without flange)

Charts: Air flow 50 Hz

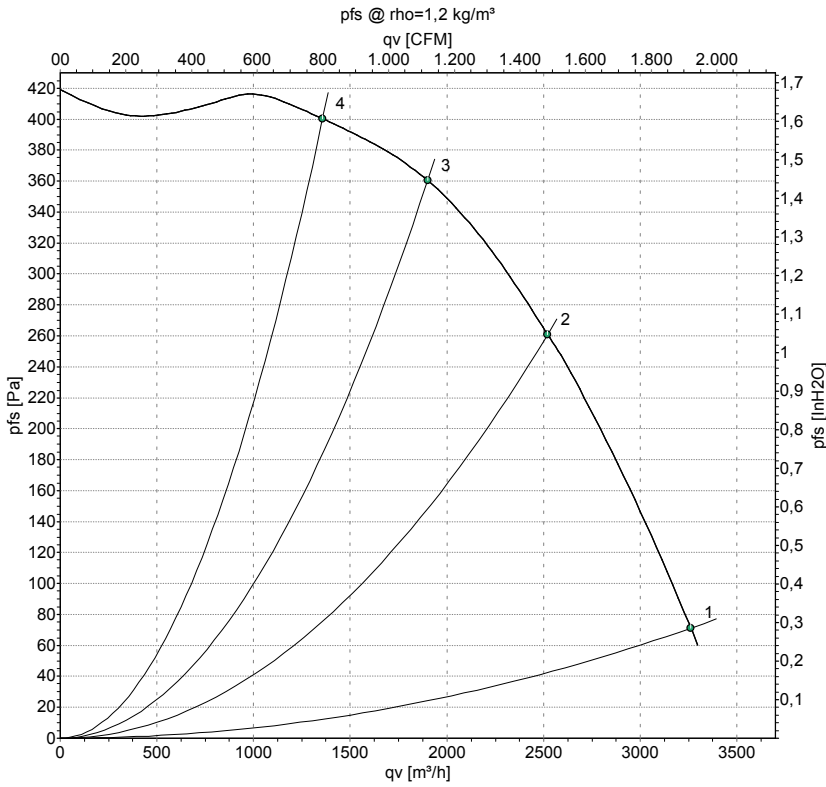

Measurement: LU-66809-1

Air performance measured as per ISO 5801 Installation category A. For detailed information on the measuring set-up, please contact ebm-papst. Suction-side noise levels: LwA measured as per ISO 13347 / LpA measured with 1m distance to fan axis. The values given are valid under the measuring conditions mentioned above and may vary according to the actual installation situation. With any deviation from the standard set-up, the specific values have to be checked and reviewed with the unit installed.

Measured values

| | U | f | n | P _e | I | q _v | P _{fs} | q _v | P _{fs} |
|---|-----|----|-------------------|----------------|------|-------------------|-----------------|----------------|-----------------|
| | V | Hz | min ⁻¹ | W | A | m ³ /h | Pa | cfm | inH2O |
| 1 | 230 | 50 | 1330 | 950 | 4.15 | 3265 | 70 | 1920 | 0.28 |
| 2 | 230 | 50 | 1375 | 748 | 3.33 | 2520 | 260 | 1485 | 1.04 |
| 3 | 230 | 50 | 1410 | 621 | 2.82 | 1900 | 360 | 1120 | 1.45 |
| 4 | 230 | 50 | 1430 | 541 | 2.50 | 1355 | 400 | 800 | 1.61 |

U = Supply voltage · f = Frequency · n = Speed (rpm) · P_e = Power input · I = Current draw · q_v = Air flow · P_{fs} = Pressure increase

