

D4E225-EH01-01

AC centrifugal fan

forward-curved, dual-intake

with housing (flange)



D4E225-EH01-01 ebmpapst Datasheet

sales@fansco.com

www.fansco.com

Nominal data

Type	D4E225-EH01-01		
Motor	M4E094-LA		
Phase		1~	1~
Nominal voltage	VAC	230	230
Frequency	Hz	50	60
Method of obtaining data		ml	ml
Valid for approval/standard		CE	CE
Speed (rpm)	min ⁻¹	1230	1410
Power consumption	W	1060	1085
Current draw	A	5.38	5.24
Capacitor	µF	10	10
Capacitor voltage	VDB	450	500
Min. back pressure	Pa	0	200
Min. back pressure	in. wg	0	0.8
Min. ambient temperature	°C	-40	-40
Max. ambient temperature	°C	55	45
Starting current	A	6.0	5.2

ml = Max. load · me = Max. efficiency · fa = Free air · cs = Customer specification · ce = Customer equipment
Subject to change

Data according to Commission Regulation (EU) 327/2011 (EN 17166)

		Actual	Req. 2015			
01 Overall efficiency η_e	%	41.1	41	09 Power consumption P_e	kW	0.53
02 Measurement category		B		09 Air flow q_v	m ³ /h	2115
03 Efficiency category		Total		09 Pressure increase p_f	Pa	378
04 Efficiency grade N		49.1	49	10 Speed (rpm) n	min ⁻¹	1415
05 Variable speed drive		No		11 Specific ratio*		1.00

Data obtained at optimum efficiency level.

* Specific ratio = $1 + p_f / 100\,000\text{ Pa}$

LU-202593

The efficiency values displayed for achieving conformity with the Ecodesign Regulation EU 327/2011 has been reached with defined air duct components (e.g. inlet rings). The dimensions must be requested from ebm-papst. If other air conduction geometries are used on the installation side, the ebm-papst evaluation loses its validity/the conformity must be confirmed again. The product does not fall within the scope of Regulation (EU) 2019/1781 due to the exception specified in Article 2 (2a) (motors completely integrated into a product).



AC centrifugal fan

forward-curved, dual-intake

with housing (flange)

Technical description

Weight	15.9 kg
Size	225 mm
Motor size	94
Impeller material	Sheet steel, galvanized
Housing material	Sheet steel, galvanized
Motor suspension	Motor vibration-damped on both sides
Direction of rotation	Clockwise, viewed toward rotor
Degree of protection	IP20
Insulation class	"F"
Moisture (F) / Environmental (H) protection class	H0 - dry environment
Ambient temperature note	Occasional start-up at temperatures between -40°C and -25°C is permitted. For continuous operation at ambient temperatures below -25°C (such as refrigeration applications), use must be made of a fan design with special low-temperature bearings.
Max. permitted ambient temp. for motor (transport/storage)	+80 °C
Min. permitted ambient temp. for motor (transport/storage)	-40 °C
Installation position	Any
Mode	S1
Motor bearing	Ball bearing
Touch current according to IEC 60990 (measuring circuit Fig. 4, TN system)	<= 3.5 mA
Motor protection	Thermal overload protector (TOP) with basic insulation
With cable	Axial
Protection class	I (with customer connection of protective earth)
Motor capacitor according to EN 60252-1 in safety protection class	S0
Conformity with standards	EN 60034-1 (2010); CE; UKCA
Approval	EAC



AC centrifugal fan

forward-curved, dual-intake
with housing (flange)

Product drawing

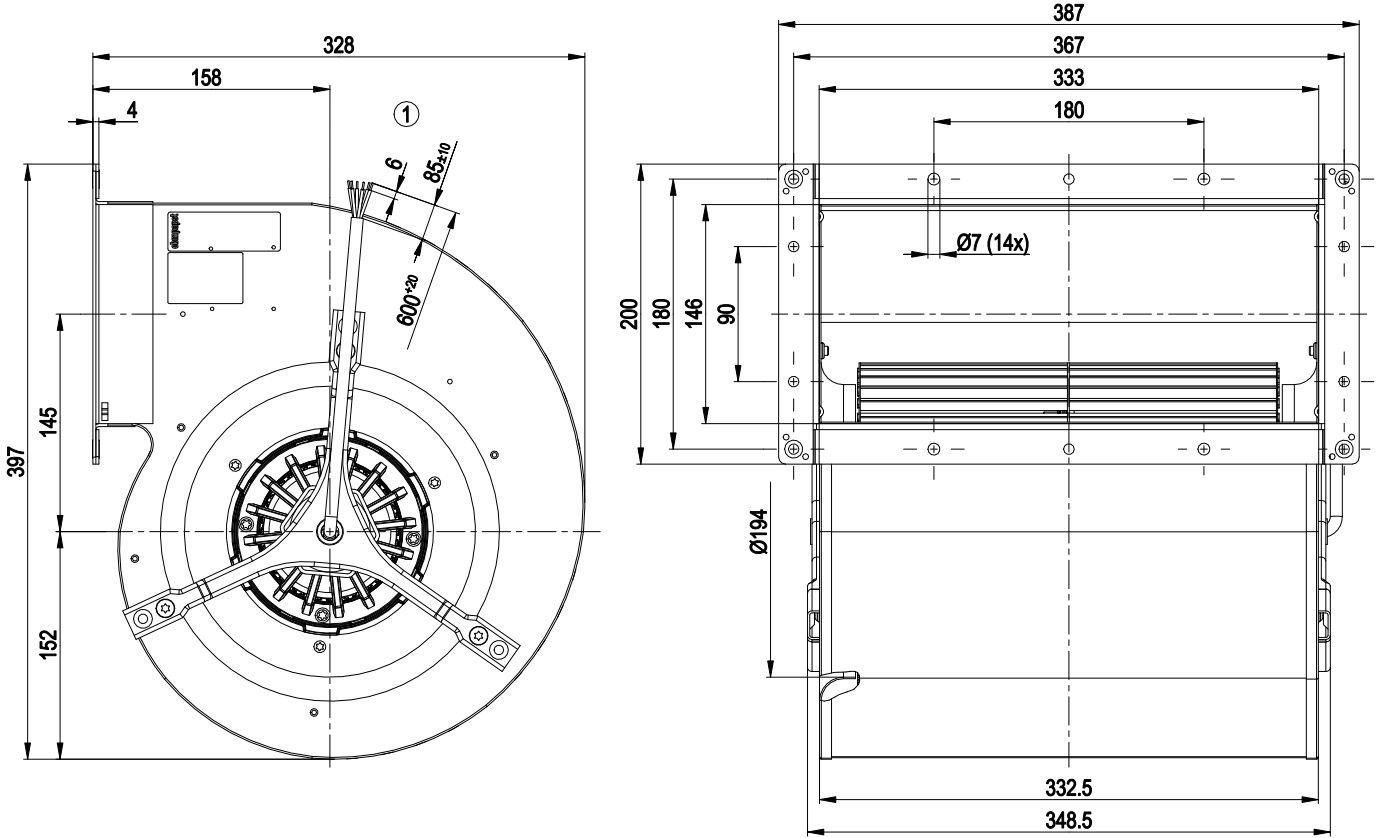

1 Cable ETFE AWG18, 6x crimped splices

Connection diagram

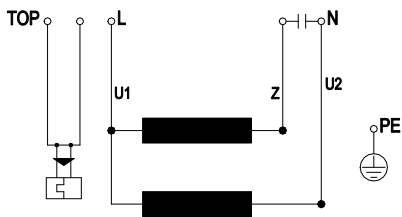

TOP	2x gray	U1	blue	Z	brown
U2	black	PE	green/yellow		



AC centrifugal fan

forward-curved, dual-intake
with housing (flange)

Curves: Air performance 50 Hz



$\rho = 1.15 \text{ kg/m}^3 \pm 2 \%$

Measurement: LU-41781-1

Air performance measured according to ISO 5801 installation category A. For detailed information on the measurement setup, contact ebmpapst. Intake sound level: Sound power level according to ISO 13347 / sound pressure level measured at 1 m distance from fan axis. The values given are valid under the specified measuring conditions and may vary due to conditions of installation. For deviations from the standard configuration, the parameters have to be checked on the installed unit.

Measured values

	Wired	U	f	n	P _e	I	q _v	P _{fs}	q _v	P _{fs}
		V	Hz	min ⁻¹	W	A	m ³ /h	Pa	cfm	in. wg
1	1~	230	50	1230	1060	5.38	3730	0	2195	0.00
2	1~	230	50	1305	879	4.51	3375	100	1990	0.40
3	1~	230	50	1360	725	3.83	2890	200	1700	0.80
4	1~	230	50	1420	502	3.00	1880	310	1105	1.24

Wired = Wiring · U = Voltage · f = Frequency · n = Speed (rpm) · P_e = Power consumption · I = Current draw · q_v = Air flow · P_{fs} = Pressure increase



AC centrifugal fan

forward-curved, dual-intake
with housing (flange)

Curves: Air performance 60 Hz

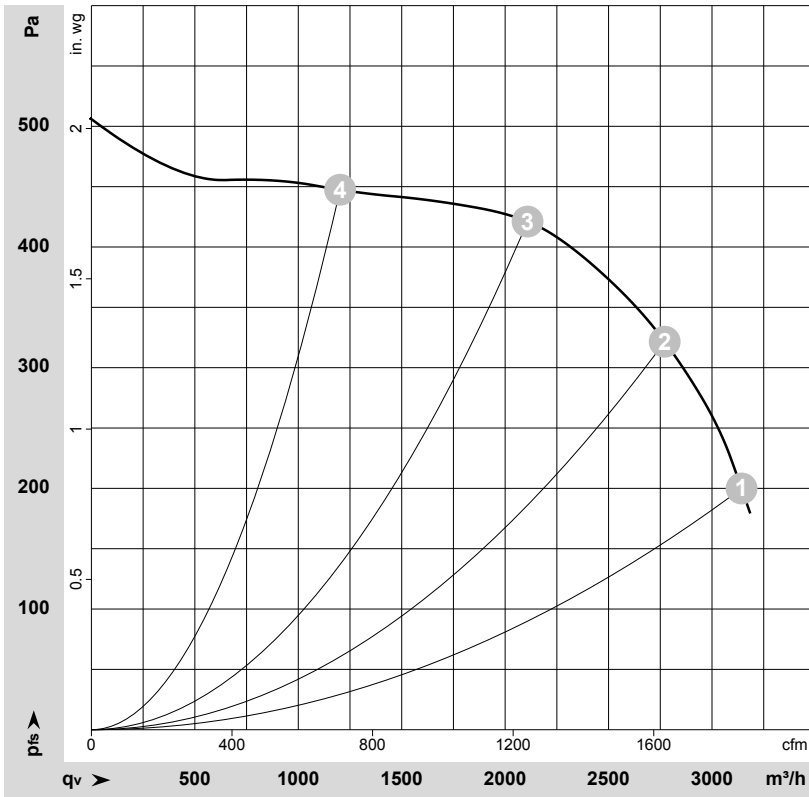

$\rho = 1.15 \text{ kg/m}^3 \pm 2 \%$

Measurement: LU-41782-1

Air performance measured according to ISO 5801 installation category A. For detailed information on the measurement setup, contact ebmpapst. Intake sound level: Sound power level according to ISO 13347 / sound pressure level measured at 1 m distance from fan axis. The values given are valid under the specified measuring conditions and may vary due to conditions of installation. For deviations from the standard configuration, the parameters have to be checked on the installed unit.

Measured values

	Wired	U	f	n	P _e	I	q _v	p _{fs}	q _v	p _{fs}
		V	Hz	min ⁻¹	W	A	m ³ /h	Pa	cfm	in. wg
1	1~	230	60	1410	1085	5.24	3145	200	1850	0.80
2	1~	230	60	1555	900	4.19	2770	320	1630	1.28
3	1~	230	60	1650	694	3.16	2110	420	1240	1.69
4	1~	230	60	1710	510	2.32	1200	450	705	1.81

Wired = Wiring · U = Voltage · f = Frequency · n = Speed (rpm) · P_e = Power consumption · I = Current draw · q_v = Air flow · p_{fs} = Pressure increase

