

# AC centrifugal fan

forward curved, dual inlet  
with housing (large flange)

D4E225-CC01-56 ebmpapst Datasheet  
sales@fansco.com  
www.fansco.com

Limited partnership · Headquarters Mulfingen  
County court Stuttgart · HRA 590344

General partner Elektrobau Mulfingen GmbH · Headquarters Mulfingen  
County court Stuttgart · HRB 590142

## Nominal data

Type	D4E225-CC01-56		
Motor	M4E074-LA		
Phase		1~	1~
Nominal voltage	VAC	230	230
Frequency	Hz	50	60
Type of data definition		ml	ml
Valid for approval / standard		CE	CE
Speed (rpm)	min <sup>-1</sup>	1210	1300
Power input	W	540	625
Current draw	A	2.4	2.75
Motor capacitor	µF	16	16
Capacitor voltage	VDB	400	400
Capacitor standard		S2 (CE)	S2 (CE)
Min. back pressure	Pa	250	300
Min. ambient temperature	°C	-25	-25
Max. ambient temperature	°C	30	30

ml = Max. load · me = Max. efficiency · fa = Running at free air · cs = Customer specs · cu = Customer unit  
Subject to alterations

## Data in accordance with ecodesign regulation EU 327/2011

		Actual	Request 2015			
01 Overall efficiency $\eta_e$	%	40.2	40.2	09 Power input $P_e$	kW	0.4
02 Measurement category		B		09 Air flow $q_v$	m <sup>3</sup> /h	1595
03 Efficiency category		Total		09 Pressure increase $p_f$	Pa	355
04 Efficiency grade N		49	49	10 Speed (rpm) n	min <sup>-1</sup>	1345
05 Variable speed drive		No		11 Specific ratio*		1.00

Data definition with optimum efficiency.  
The ErP data is determined using a motor-impeller combination in a standardised measurement configuration.

\* Specific ratio =  $1 + p_f / 100\,000\text{ Pa}$

LU-135956



# AC centrifugal fan

forward curved, dual inlet  
with housing (large flange)

## Technical features

Mass	12 kg
Size	225 mm
Motor size	74
Material of impeller	Sheet steel, galvanised
Housing material	Sheet steel, galvanised
Material of guard grille	Steel, coated in white aluminium plastic (RAL 9006)
Motor suspension	Motor mounted anti-vibration on both sides
Direction of rotation	Counter-clockwise, seen on rotor
Type of protection	IP22
Insulation class	"B"
Humidity (F) / environmental protection class (H)	H0 - dry environment
Max. permissible ambient motor temp. (transp./ storage)	+ 80 °C
Min. permissible ambient motor temp. (transp./storage)	- 40 °C
Mounting position	Any
Condensation drainage holes	None, open rotor
Operation mode	S1
Motor bearing	Ball bearings made of stainless steel
Touch current acc. IEC 60990 (measuring network Fig. 4, TN system)	< 0.75 mA
Motor protection	Thermal overload protector (TOP) brought out, basic insulation
Protection class	I (if protective earth is connected by customer)
Motor capacitor according to EN 60252-1 in safety protection class	S2
Product conforming to standard	EN 60335-1; CE
Approval	UL 1004-1; CCC; CSA C22.2 no. 100



# AC centrifugal fan

forward curved, dual inlet  
with housing (large flange)

## Product drawing

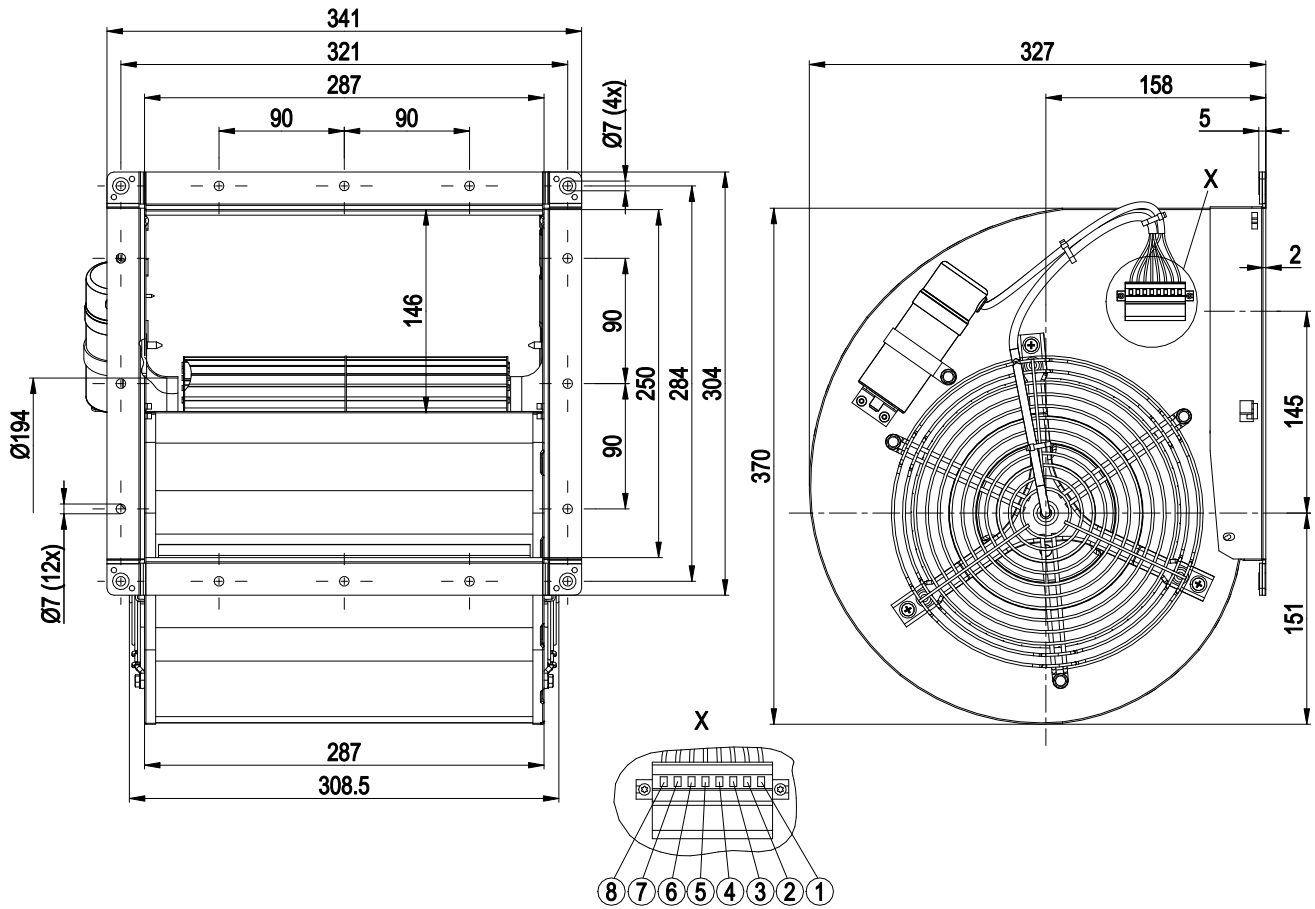

1	Capacitor	2	Z (brown)	3	L (blue)
4	TOP (grey)	5	PE (green/yellow)	6	TOP (grey)
7	Capacitor	8	N (black)		



# AC centrifugal fan

forward curved, dual inlet  
with housing (large flange)

## Connection screen

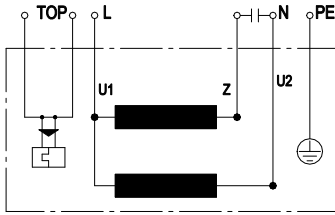

U1	Blue	Z	brown	U2	black
PE	green/yellow	TOP	2 x grey		



# AC centrifugal fan

forward curved, dual inlet  
with housing (large flange)

## Charts: Air flow 50 Hz

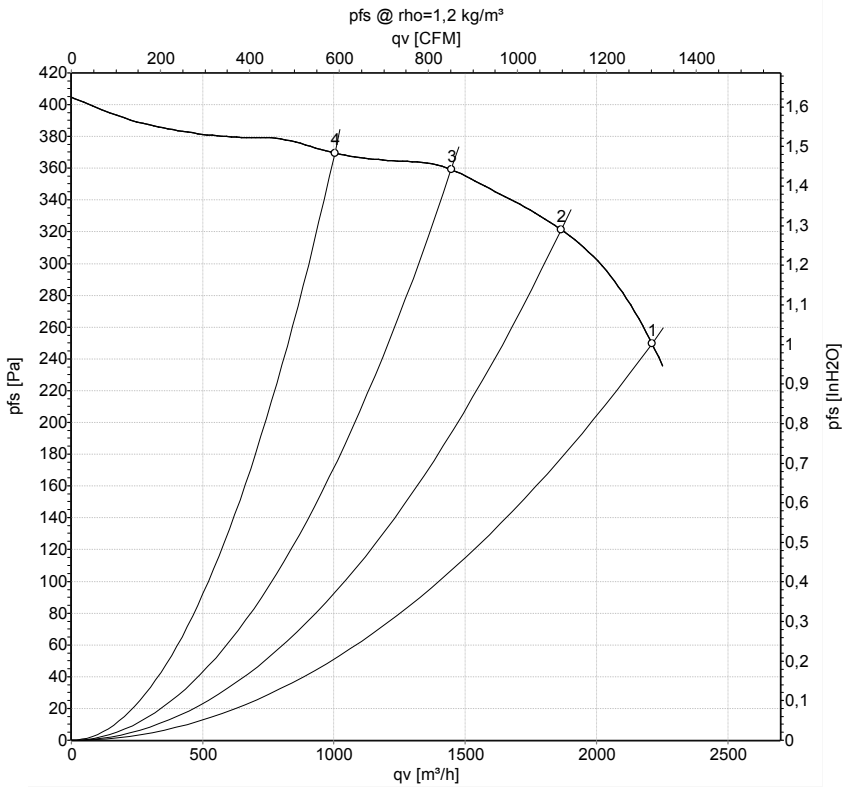

Measurement: LU-135956-1

Air performance measured as per ISO 5801 Installation category A. For detailed information on the measuring set-up, please contact ebm-papst. Suction-side noise levels: LwA measured as per ISO 13347 / LpA measured with 1m distance to fan axis. The values given are valid under the measuring conditions mentioned above and may vary according to the actual installation situation. With any deviation from the standard set-up, the specific values have to be checked and reviewed with the unit installed.

## Measured values

	U	f	n	P <sub>e</sub>	I	q <sub>v</sub>	P <sub>fs</sub>	q <sub>v</sub>	P <sub>fs</sub>
	V	Hz	min <sup>-1</sup>	W	A	m <sup>3</sup> /h	Pa	cfm	in. wg
1	230	50	1210	540	2.40	2210	250	1300	1.00
2	230	50	1300	459	2.04	1865	320	1100	1.28
3	230	50	1365	378	1.71	1445	360	850	1.45
4	230	50	1405	320	1.48	1005	370	590	1.49

U = Supply voltage · f = Frequency · n = Speed (rpm) · P<sub>e</sub> = Power input · I = Current draw · q<sub>v</sub> = Air flow · P<sub>fs</sub> = Pressure increase



# AC centrifugal fan

forward curved, dual inlet  
with housing (large flange)

## Charts: Air flow 60 Hz

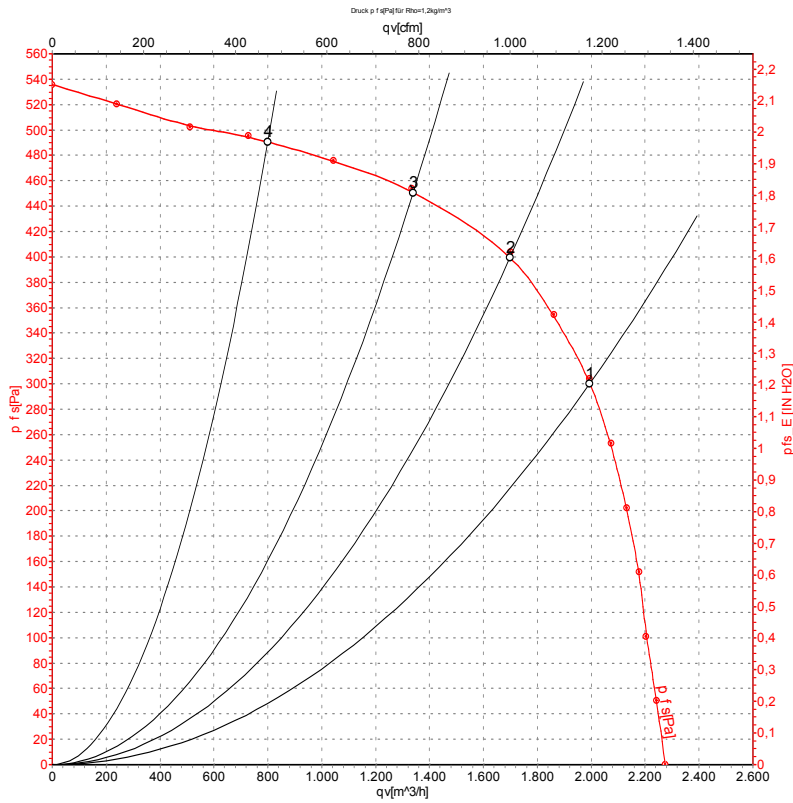

Measurement: LU-35316-1

Air performance measured as per ISO 5801 Installation category A. For detailed information on the measuring set-up, please contact ebmpapst. Suction-side noise levels: LwA measured as per ISO 13347 / LpA measured with 1m distance to fan axis. The values given are valid under the measuring conditions mentioned above and may vary according to the actual installation situation. With any deviation from the standard set-up, the specific values have to be checked and reviewed with the unit installed.

## Measured values

	U	f	n	Pe	I	qv	Pfs	qv	Pfs
	V	Hz	min <sup>-1</sup>	W	A	m <sup>3</sup> /h	Pa	cfm	in. wg
1	230	60	1300	625	2.75	1995	300	1175	1.20
2	230	60	1465	553	2.43	1700	400	1000	1.61
3	230	60	1565	474	2.13	1340	450	790	1.81
4	230	60	1645	390	1.83	800	490	470	1.97

U = Supply voltage · f = Frequency · n = Speed (rpm) · Pe = Power input · I = Current draw · qv = Air flow · Pfs = Pressure increase

