

D4E160-FQ38-10 ebmpapst Datasheet

sales@fansco.com

www.fansco.com

Nominal data

Type	D4E160-FQ38-10		
Motor	M4E068-EC		
Phase		1~	1~
Nominal voltage	VAC	230	230
Frequency	Hz	50	60
Type of data definition		cu	cu
Valid for approval / standard		CE	CE
Speed	min ⁻¹	1350	1430
Power input	W	140	170
Current draw	A	0.62	0.74
Motor capacitor	µF	5	4
Capacitor voltage	VDB	400	400
Min. back pressure	Pa	100	120
Max. ambient temperature	°C	38	60

ml = Max. load · me = Max. efficiency · fa = Running at free air · cs = Customer specs · cu = Customer unit
Subject to alterations



Technical features

Mass	5.2 kg
Size	160 mm
Surface of rotor	Uncoated
Material of impeller	Sheet steel, hot-galvanised
Housing material	Sheet steel, hot-galvanised
Motor suspension	Motor anti-vibration mounted on both sides
Direction of rotation	Counter-clockwise, seen on rotor
Type of protection	IP 00
Insulation class	"F"
Humidity class	F0
Max. permissible ambient motor temp. (transp./ storage)	+ 80 °C
Min. permissible ambient motor temp. (transp./storage)	- 40 °C
Mounting position	Shaft horizontal or rotor on bottom; rotor on top on request
Condensate discharge holes	None, open rotor
Operation mode	S1
Motor bearing	Ball bearing
Touch current acc. IEC 60990 (measuring network Fig. 4, TN system)	< 0.75 mA
Electrical leads	Via terminal strips, integrated capacitor connected via terminal strips
Motor protection	Thermal overload protector (TOP) wired internally
Cable exit	Axial
Protection class	I (if protective earth is connected by customer)
Product conforming to standard	EN 60335-1; CE

AC centrifugal fan

forward curved, dual inlet

Product drawing

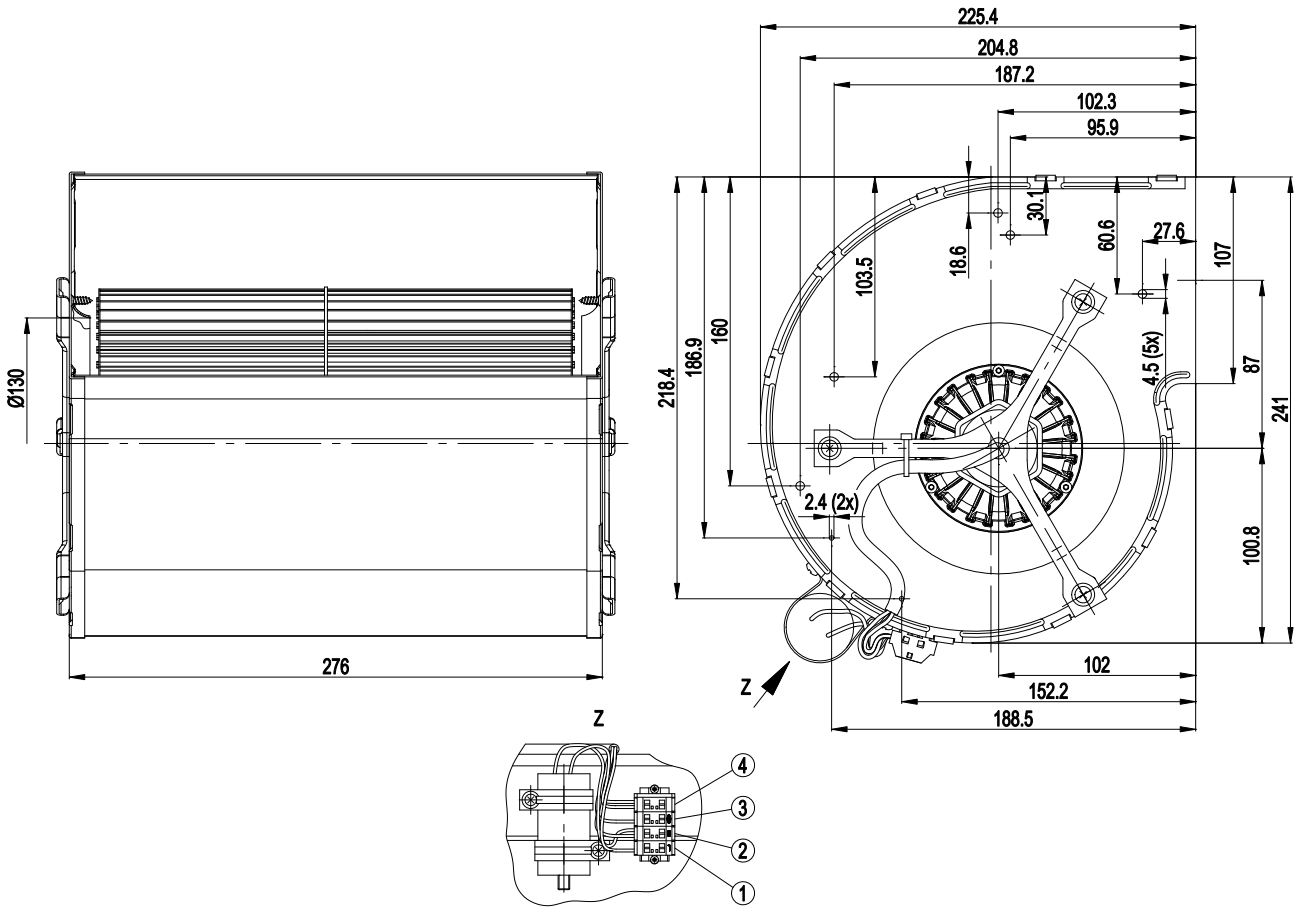

1	U1	2	U2	3	PE
4	Z				



D4E160-FQ38-10

AC centrifugal fan

forward curved, dual inlet

Terminal connections

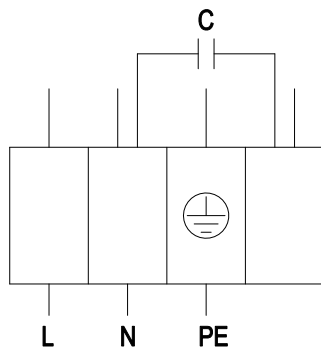

L	blue	N	black	PE	green/yellow
---	------	---	-------	----	--------------



Charts: Air flow 50 Hz

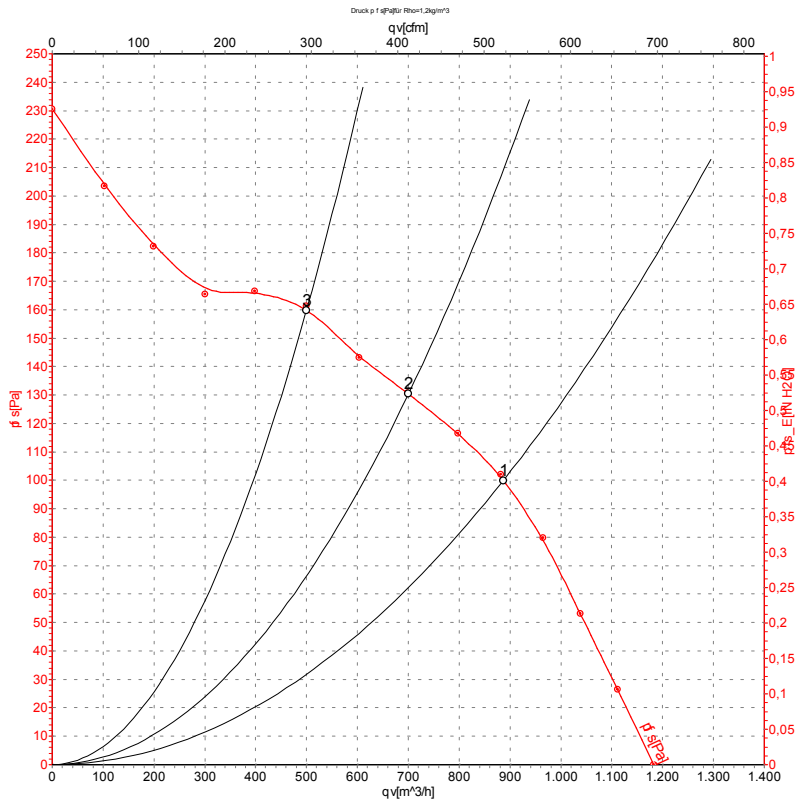

Measurement: LU-119525

Air performance measured as per ISO 5801 Installation category A. For detailed information on the measuring set-up, please contact ebm-papst. Suction-side noise levels: LwA measured as per ISO 13347 / LpA measured with 1m distance to fan axis. The values given are valid under the measuring conditions mentioned above and may vary according to the actual installation situation. With any deviation from the standard set-up, the specific values have to be checked and reviewed with the unit installed.

Measured values

	U	f	n	P _e	I	LpA _{in}	LwA _{in}	qv	p _{fs}
	V	Hz	min ⁻¹	W	A	dB(A)	dB(A)	m ³ /h	Pa
1	230	50	1350	140	0.62	53	65	885	100
2	230	50	1400	134	0.59	52	64	700	130
3	230	50	1420	126	0.56	49	61	500	160

U = Supply voltage · f = Frequency · n = Speed · P_e = Power input · I = Current draw · LpA_{in} = Sound pressure level inlet side · LwA_{in} = Sound power level inlet side · qv = Air flow
 p_{fs} = Pressure increase



Charts: Air flow 60 Hz

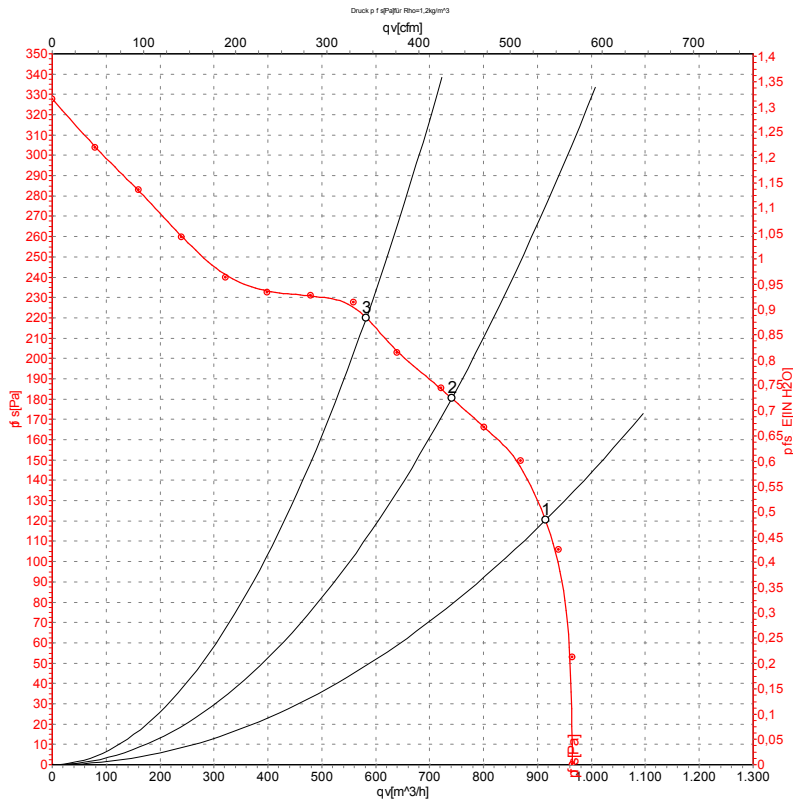

Measurement: LU-119532

Air performance measured as per ISO 5801 Installation category A. For detailed information on the measuring set-up, please contact ebm-papst. Suction-side noise levels: L_{wA} measured as per ISO 13347 / L_{pA} measured with 1m distance to fan axis. The values given are valid under the measuring conditions mentioned above and may vary according to the actual installation situation. With any deviation from the standard set-up, the specific values have to be checked and reviewed with the unit installed.

Measured values

	U	f	n	P _e	I	L _{pA_{in}}	L _{wA_{in}}	qv	p _{fs}
	V	Hz	min ⁻¹	W	A	dB(A)	dB(A)	m ³ /h	Pa
1	230	60	1430	170	0.74	55	66	915	120
2	230	60	1590	149	0.65	55	66	740	180
3	230	60	1645	137	0.60	54	66	580	220

U = Supply voltage · f = Frequency · n = Speed · P_e = Power input · I = Current draw · L_{pA_{in}} = Sound pressure level inlet side · L_{wA_{in}} = Sound power level inlet side · qv = Air flow
p_{fs} = Pressure increase

