

D4E146-LV19-36

# AC centrifugal fan

forward curved, dual inlet

with housing (flange)



D4E146-LV19-36 ebmpapst Datasheet

[sales@fansco.com](mailto:sales@fansco.com)

[www.fansco.com](http://www.fansco.com)

## Nominal data

Type	D4E146-LV19-36		
Motor	M4E068-CF		
Phase		1~	1~
Nominal voltage	VAC	230	230
Frequency	Hz	50	60
Type of data definition		fa	fa
Valid for approval / standard		CE	CE
Speed (rpm)	min <sup>-1</sup>	780	710
Power input	W	65	68
Current draw	A	0.29	0.3
Motor capacitor	µF	2	2
Capacitor voltage	VDB	400	400
Capacitor standard		S2 (CE)	S2 (CE)
Min. back pressure	Pa	0	0
Min. ambient temperature	°C	-25	-25
Max. ambient temperature	°C	50	40
Starting current	A	0.33	0.33

ml = Max. load · me = Max. efficiency · fa = Running at free air · cs = Customer specs · cu = Customer unit  
Subject to alterations



# AC centrifugal fan

forward curved, dual inlet  
with housing (flange)

## Technical features

<b>Mass</b>	2.6 kg
<b>Size</b>	146 mm
<b>Surface of rotor</b>	Uncoated
<b>Material of terminal box</b>	PP plastic
<b>Material of impeller</b>	PA plastic
<b>Housing material</b>	PP plastic
<b>Motor suspension</b>	Motor mounted anti-vibration on both sides
<b>Direction of rotation</b>	Counter-clockwise, seen on rotor
<b>Type of protection</b>	IP 44; Depending on installation and position
<b>Insulation class</b>	"F"
<b>Humidity (F)/environmental protection class (H)</b>	H0 - dry environment
<b>Max. permissible ambient motor temp. (transp./ storage)</b>	+ 80 °C
<b>Min. permissible ambient motor temp. (transp./storage)</b>	- 40 °C
<b>Mounting position</b>	Any
<b>Condensate discharge holes</b>	None
<b>Operation mode</b>	S1
<b>Motor bearing</b>	Ball bearing
<b>Speed steps</b>	5
<b>Touch current acc. IEC 60990 (measuring network Fig. 4, TN system)</b>	< 0.75 mA
<b>Electrical leads</b>	With plug; Via terminal box, integrated capacitor connected via terminal box
<b>Motor protection</b>	Thermal overload protector (TOP) wired internally
<b>Cable exit</b>	Axial
<b>Protection class</b>	I (if protective earth is connected by customer)
<b>Motor capacitor according to EN 60252-1 in safety protection class</b>	S2
<b>Product conforming to standard</b>	EN 60335-1; CE



# AC centrifugal fan

forward curved, dual inlet  
with housing (flange)

## Product drawing

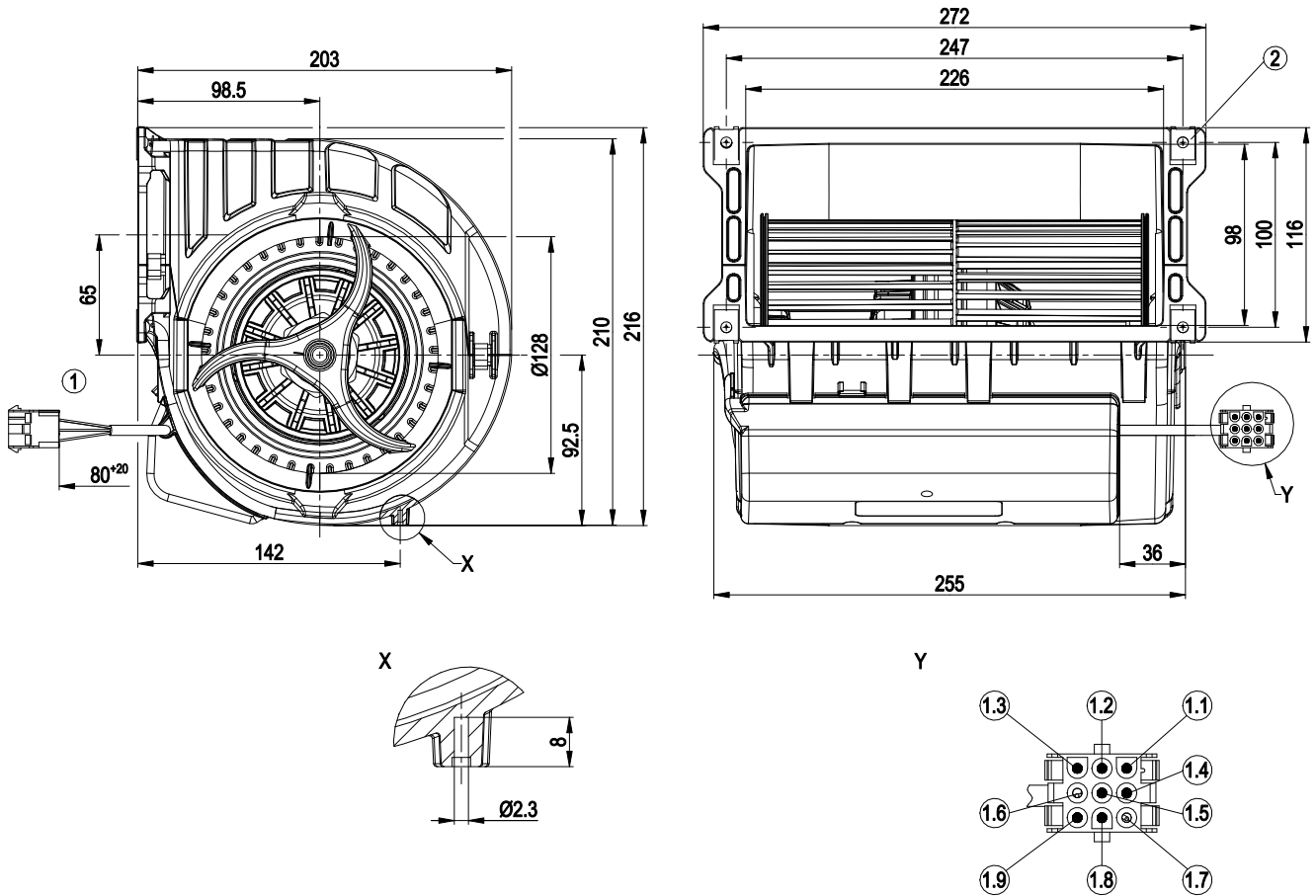

1	Connection line ETFE AWG20, 1x plug pin tyco 926886-1, connection line ETFE AWG22, 6x plug pin tyco 926886-1, 1x 9-pole connector housing tyco 927231-5
1.1	Level 1 (min.)
1.2	Level 2
1.3	Level 3
1.4	Level 4
1.5	Level 5 (max.)
1.6	-
1.7	-
1.8	N
1.9	Protective earth
2	4x sheet metal nut for thread EN ISO 1478-ST4.8 (min. screw length 14.5 mm plus thickness of mounting material)



# AC centrifugal fan

forward curved, dual inlet  
with housing (flange)

## Connection screen

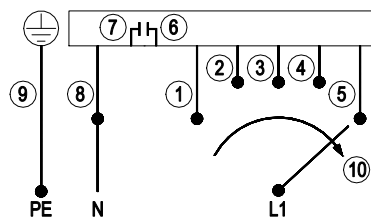

When changing speeds, switch must break the circuit

1	Step 1 (min.)	2	Step 2	3	Step 3
4	Step 4	5	Step 5 (max.)	6	Capacitor
7	Capacitor	8	N	9	Protective earth
10	Speed increase				



# AC centrifugal fan

forward curved, dual inlet  
with housing (flange)

## Charts: Air flow 50 Hz

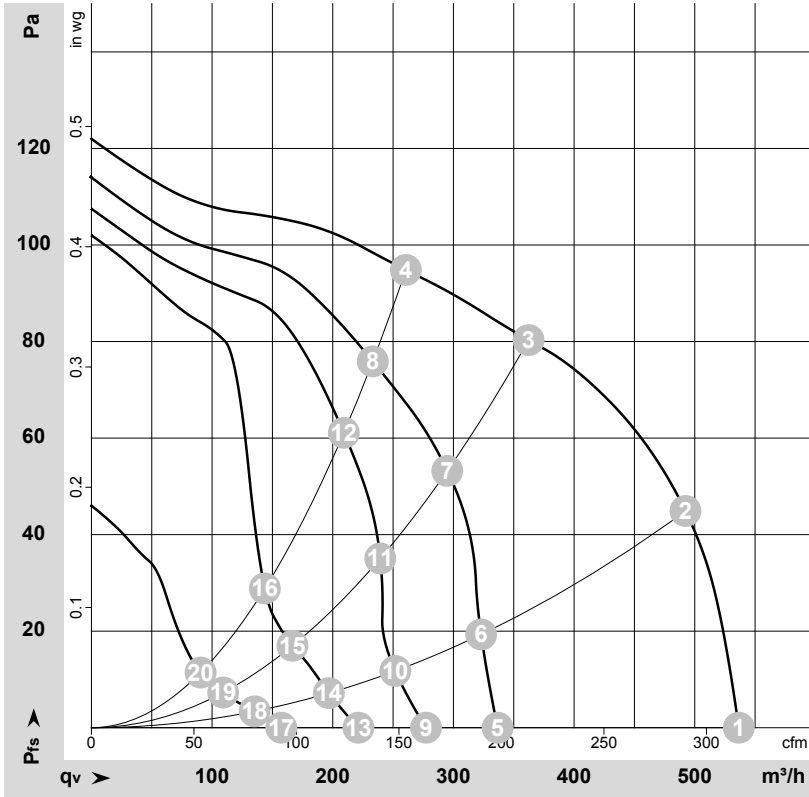

$\rho = 1.15 \text{ kg/m}^3 \pm 2 \%$

Measurement: LU-68469-1  
Measurement: LU-68471-1  
Measurement: LU-68472-1  
Measurement: LU-68473-1  
Measurement: LU-68474-1

Air performance measured as per ISO 5801 Installation category A. For detailed information on the measuring set-up, please contact ebmpapst. Suction-side noise levels: LwA measured as per ISO 13347 / LpA measured with 1m distance to fan axis. The values given are valid under the measuring conditions mentioned above and may vary according to the actual installation situation. With any deviation from the standard set-up, the specific values have to be checked and reviewed with the unit installed.

## Measured values

	Stage	U	f	n	P <sub>e</sub>	I	q <sub>v</sub>	P <sub>fs</sub>	q <sub>v</sub>	P <sub>fs</sub>
		V	Hz	min <sup>-1</sup>	W	A	m <sup>3</sup> /h	Pa	cfm	inH <sub>2</sub> O
1	5	230	50	780	65	0.29	535	0	315	0.00
2	5	230	50	1080	58	0.25	490	45	290	0.18
3	5	230	50	1285	47	0.21	360	80	215	0.32
4	5	230	50	1345	43	0.19	260	95	155	0.38
5	4	230	50	495	54	0.24	335	0	200	0.00
6	4	230	50	690	52	0.23	325	17	190	0.07
7	4	230	50	1050	45	0.21	295	53	175	0.21
8	4	230	50	1215	39	0.18	235	76	135	0.31
9	3	230	50	390	50	0.22	275	0	165	0.00
10	3	230	50	560	48	0.22	250	10	150	0.04
11	3	230	50	870	45	0.21	240	35	140	0.14
12	3	230	50	1085	40	0.19	210	61	125	0.24
13	2	230	50	345	20	0.16	220	0	130	0.00
14	2	230	50	445	20	0.16	195	7	115	0.03
15	2	230	50	605	20	0.16	165	17	100	0.07
16	2	230	50	735	20	0.16	145	26	85	0.10
17	1	230	50	245	13	0.13	155	0	90	0.00
18	1	230	50	315	13	0.13	135	3	80	0.01
19	1	230	50	405	13	0.13	110	7	65	0.03
20	1	230	50	480	13	0.13	90	11	55	0.04

U = Supply voltage · f = Frequency · n = Speed (rpm) · P<sub>e</sub> = Power input · I = Current draw · q<sub>v</sub> = Air flow · p<sub>fs</sub> = Pressure increase



# AC centrifugal fan

forward curved, dual inlet  
with housing (flange)

## Charts: Air flow 60 Hz

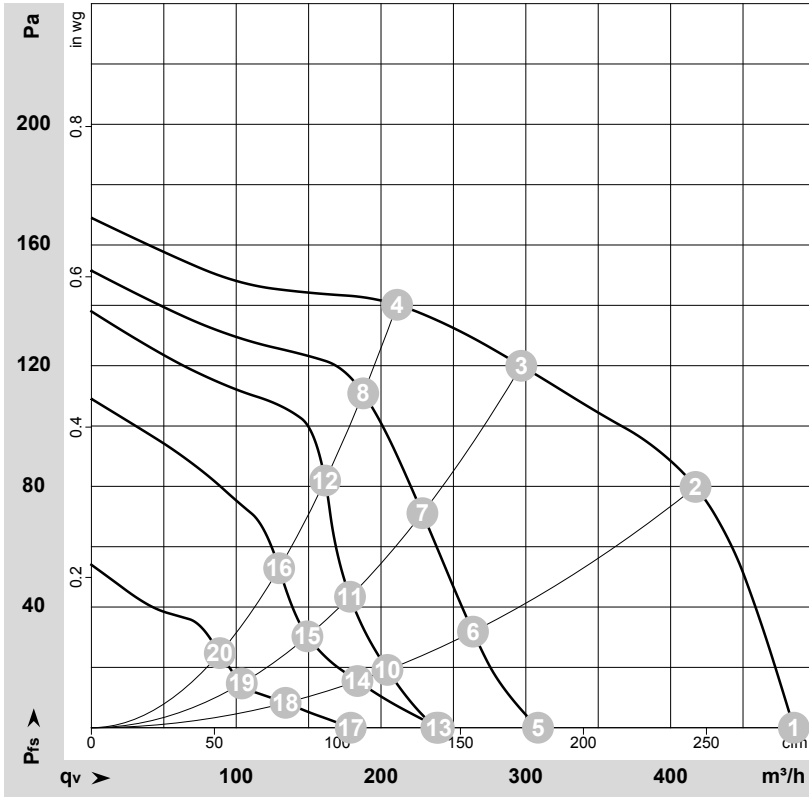

$\rho = 1.15 \text{ kg/m}^3 \pm 2 \%$

Measurement: LU-68484-1  
Measurement: LU-68487-1  
Measurement: LU-68490-1  
Measurement: LU-68493-1  
Measurement: LU-68495-1

Air performance measured as per ISO 5801 Installation category A. For detailed information on the measuring set-up, please contact ebmpapst. Suction-side noise levels: LwA measured as per ISO 13347 / LpA measured with 1m distance to fan axis. The values given are valid under the measuring conditions mentioned above and may vary according to the actual installation situation. With any deviation from the standard set-up, the specific values have to be checked and reviewed with the unit installed.

## Measured values

	Stage	U	f	n	P <sub>e</sub>	I	q <sub>v</sub>	P <sub>fs</sub>	q <sub>v</sub>	P <sub>fs</sub>
		V	Hz	min <sup>-1</sup>	W	A	m <sup>3</sup> /h	Pa	cfm	inH2O
1	5	230	60	710	68	0.30	485	0	285	0.00
2	5	230	60	1300	61	0.28	415	80	245	0.32
3	5	230	60	1520	53	0.25	295	120	175	0.48
4	5	230	60	1620	47	0.23	210	140	125	0.56
5	4	230	60	465	52	0.24	310	0	180	0.00
6	4	230	60	830	50	0.24	265	31	155	0.12
7	4	230	60	1175	46	0.23	230	71	135	0.29
8	4	230	60	1440	39	0.21	190	111	110	0.45
9	3	230	60	380	47	0.22	240	0	140	0.00
10	3	230	60	620	46	0.22	205	19	120	0.08
11	3	230	60	870	44	0.22	180	40	105	0.16
12	3	230	60	1255	38	0.20	160	84	95	0.34
13	2	230	60	360	23	0.18	240	0	140	0.00
14	2	230	60	590	23	0.18	185	15	110	0.06
15	2	230	60	775	22	0.17	150	30	90	0.12
16	2	230	60	1005	22	0.17	130	53	75	0.21
17	1	230	60	280	15	0.14	180	0	105	0.00
18	1	230	60	435	15	0.14	135	8	80	0.03
19	1	230	60	545	15	0.14	105	14	60	0.06
20	1	230	60	695	15	0.14	90	25	50	0.10

U = Supply voltage · f = Frequency · n = Speed (rpm) · P<sub>e</sub> = Power input · I = Current draw · q<sub>v</sub> = Air flow · p<sub>fs</sub> = Pressure increase

