

D3G318-AA37-11

EC centrifugal fan

forward curved, dual inlet
with housing (large flange)



D3G318-AA37-11 ebmpapst Datasheet
sales@fansco.com
www.fansco.com

Limited partnership · Headquarters Muldingen
County court Stuttgart · HRA 590344

General partner Elektrobau Muldingen GmbH · Headquarters Muldingen
County court Stuttgart · HRB 590142

Nominal data

Type	D3G318-AA37-11	
Motor	M3G112-GA	
Phase		1~
Nominal voltage	VAC	230
Nominal voltage range	VAC	200 .. 277
Frequency	Hz	50/60
Type of data definition		ml
State		prelim.
Speed (rpm)	min ⁻¹	960
Power input	W	750
Current draw	A	3.4
Min. back pressure	Pa	260
Min. ambient temperature	°C	-25
Max. ambient temperature	°C	40

ml = Max. load · me = Max. efficiency · fa = Running at free air · cs = Customer specs · cu = Customer unit
Subject to alterations

Data according to ErP directive

		Actual	Request 2015
01 Overall efficiency η_{es}	%	54.4	35.2
02 Measurement category		A	
03 Efficiency category		Static	
04 Efficiency grade N		63.2	44
05 Variable speed drive		Yes	

Data definition with optimum efficiency.
The ErP data is determined using a motor-impeller combination in a standardised measurement configuration.

09 Power input P_{ed}	kW	0.41
09 Air flow q_v	m ³ /h	1995
09 Pressure increase p_{fs}	Pa	371
10 Speed (rpm) n	min ⁻¹	1110
11 Specific ratio*		1.00

* Specific ratio = $1 + p_{fs} / 100\,000\text{ Pa}$

LU-107510



EC centrifugal fan

forward curved, dual inlet
with housing (large flange)

Technical features

Mass	21.2 kg
Size	318 mm
Surface of rotor	Coated in black
Material of electronics housing	Die-cast aluminum
Material of impeller	Sheet steel, galvanised
Housing material	Sheet steel, galvanised
Motor suspension	Motor anti-vibration mounted on one side via brackets
Direction of rotation	Clockwise, seen on rotor
Type of protection	IP 54
Insulation class	"B"
Humidity (F)/environmental protection class (H)	F4-1
Max. permissible ambient motor temp. (transp./ storage)	+80 °C
Min. permissible ambient motor temp. (transp./storage)	-40 °C
Mounting position	Shaft horizontal
Condensate discharge holes	None
Operation mode	S1
Motor bearing	Ball bearing
Technical features	<ul style="list-style-type: none"> - Output 10 VDC, max. 10 mA - Alarm relay - Motor current limit - PFC, active - Soft start - Control input 0-10 VDC Control interface with SELV potential safely disconnected from the mains - Over-temperature protected electronics / motor - Line undervoltage / phase failure detection
EMC interference immunity	Acc. to EN 61000-6-2 (industrial environment)
EMC harmonics	Acc. to EN 61000-3-2/3
EMC interference emission	Acc. to EN 61000-6-4 (industrial environment)
Touch current acc. IEC 60990 (measuring network Fig. 4, TN system)	<= 3.5 mA
Motor protection	Thermal overload protector (TOP) wired internally
Cable exit	Variable
Protection class	I (if protective earth is connected by customer)
Product conforming to standard	EN 61800-5-1; CE
Approval	EAC



EC centrifugal fan

forward curved, dual inlet
with housing (large flange)

Product drawing

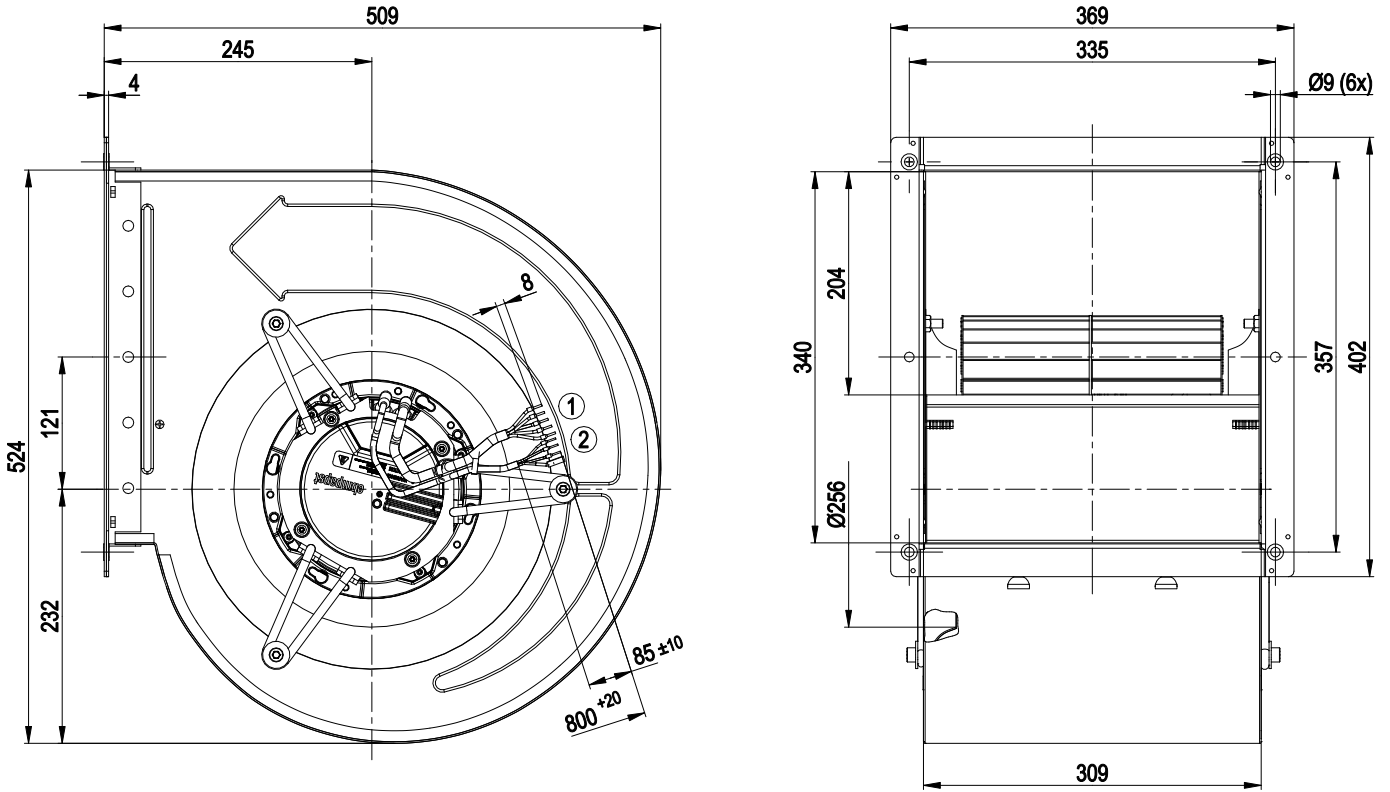

Cable length from electronics enclosure: 800+20 mm

1	Connection line PVC AWG18, 5x crimped core-end sleeves
2	Connection line PVC AWG22, 3x crimped core-end sleeves



EC centrifugal fan

forward curved, dual inlet
with housing (large flange)

Connection screen

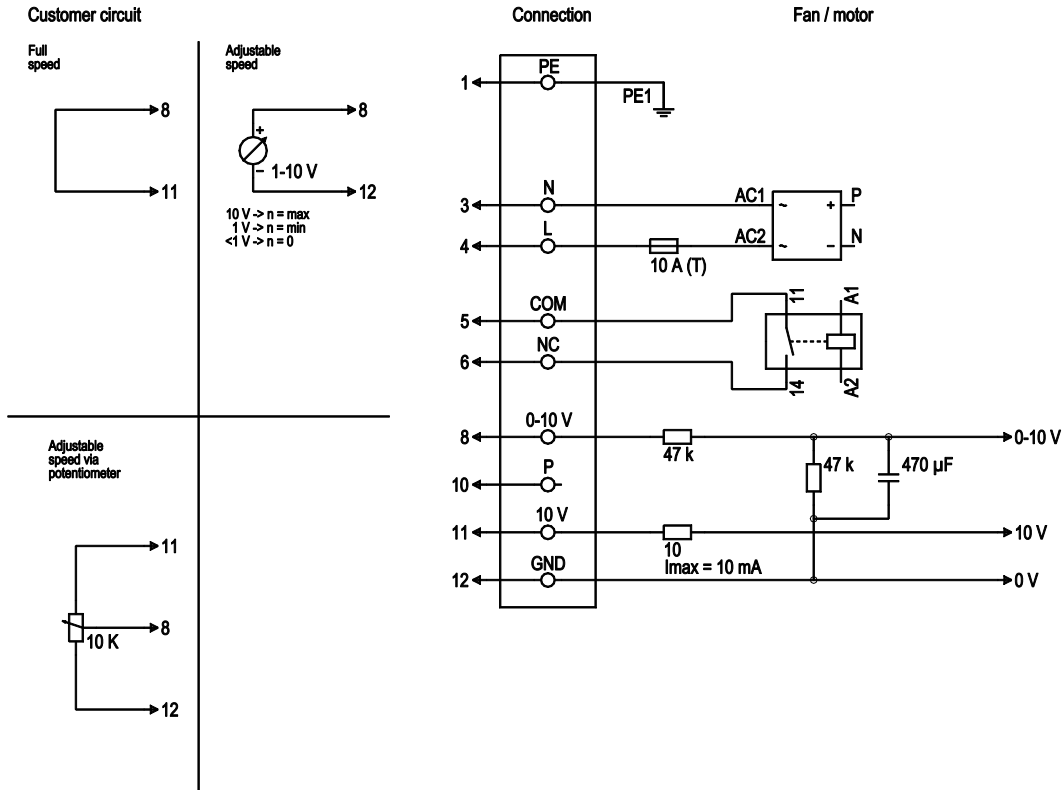

No.	Conn.	Designation	Colour	Function / assignment
1	1	PE	green/yellow	Ground wire
1	3	N	blue	Supply voltage, neutral conductor, 50/60 Hz
1	4	L	black	Supply voltage, phase, 50/60 Hz
1	5	COM	white 1	Floating status message contact, normally closed connection (2 A, max. 250 VAC, min. 10 mA, AC1)
1	6	NC	white 2	Floating status message contact, normally closed connection
2	8	0-10 V	yellow	Control input, set value 0-10 VDC, impedance 100 kΩ, SELV
2	10	P	orange	not assigned
2	11	10 VDC	red	Voltage output 10 VDC (+/-3 %), max. 10 mA, supply voltage for external devices (e.g. potentiometer), SELV
2	12	GND	blue	Reference mass for control interface, SELV



EC centrifugal fan

forward curved, dual inlet
with housing (large flange)

Charts: Air flow

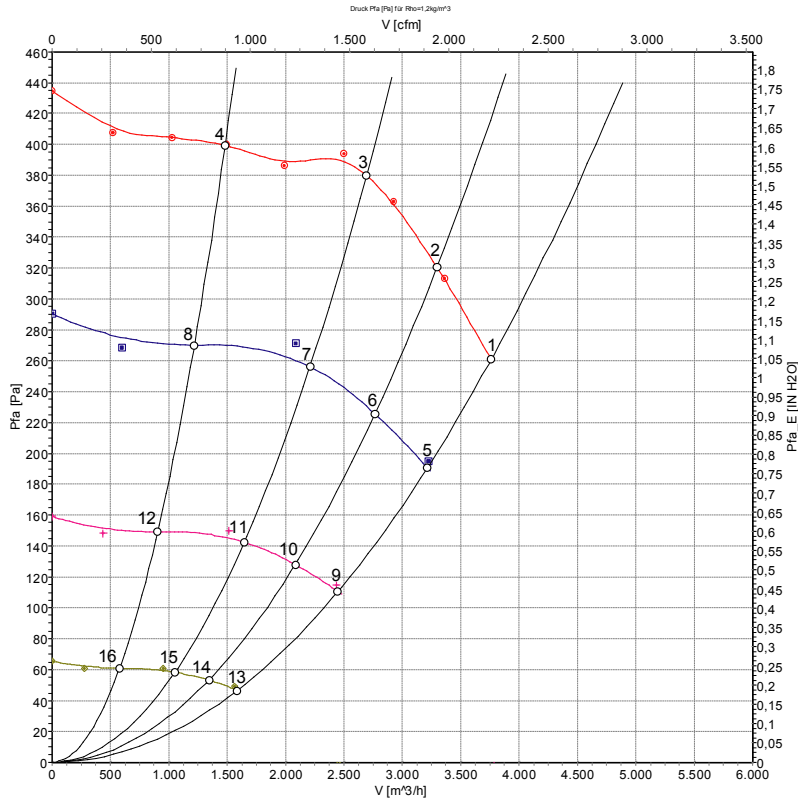

Measurement: LU-107510-1
Measurement: LU-107612-1
Measurement: LU-107611-1
Measurement: LU-107610-1

Air performance measured as per ISO 5801 Installation category A. For detailed information on the measuring set-up, please contact ebmpapst. Suction-side noise levels: L_{wA} measured as per ISO 13347 / L_{pA} measured with 1m distance to fan axis. The values given are valid under the measuring conditions mentioned above and may vary according to the actual installation situation. With any deviation from the standard set-up, the specific values have to be checked and reviewed with the unit installed.

Measured values

	U	f	n	P _{ed}	I	L _{pA_{in}}	L _{wA_{in}}	L _{wA_{out}}	q _v	P _{fs}	q _v	P _{fs}
	V	Hz	min ⁻¹	W	A	dB(A)	dB(A)	dB(A)	m ³ /h	Pa	cfm	inH ₂ O
1	230	50	960	750	3.40	70	79	81	3760	260	2215	1.04
2	230	50	995	670	3.00	68	77	79	3295	320	1940	1.28
3	230	50	1040	570	2.58	67	75	78	2695	380	1585	1.53
4	230	50	1085	329	1.70	67	75	78	1485	400	875	1.61
5	230	50	830	456	2.10	66	74	75	3215	196	1890	0.79
6	230	50	850	393	1.81	64	72	74	2765	226	1630	0.91
7	230	50	880	314	1.46	62	70	72	2210	263	1300	1.06
8	230	50	905	210	1.13	60	69	71	1220	270	715	1.08
9	230	50	630	208	0.98	58	67	69	2450	114	1440	0.46
10	230	50	645	180	0.88	57	66	67	2085	128	1225	0.51
11	230	50	660	146	0.75	55	64	65	1650	145	970	0.58
12	230	50	680	100	0.54	52	61	62	905	149	535	0.60
13	230	50	410	67	0.38	47	55	55	1585	48	935	0.19
14	230	50	420	60	0.34	45	53	53	1345	53	790	0.21
15	230	50	425	52	0.29	43	51	51	1055	59	620	0.24
16	230	50	440	40	0.23	40	50	50	580	61	340	0.24

U = Supply voltage · f = Frequency · n = Speed (rpm) · P_{ed} = Power input · I = Current draw · L_{pA_{in}} = Sound pressure level inlet side · L_{wA_{in}} = Sound power level inlet side · L_{wA_{out}} = Sound power level outlet side
q_v = Air flow · P_{fs} = Pressure increase

