

EC centrifugal fan

forward curved, dual inlet
with housing (large flange)

D3G283-AA66-05 ebmpapst Datasheet
sales@fansco.com
www.fansco.com

Nominal data

Type	D3G283-AA66-05	
Motor	M3G112-EA	
Phase		3~
Nominal voltage	VAC	400
Nominal voltage range	VAC	380 .. 480
Frequency	Hz	50/60
Type of data definition		ml
Speed (rpm)	min ⁻¹	1500
Power input	W	750
Current draw	A	1.5
Min. back pressure	Pa	0
Min. ambient temperature	°C	-25
Max. ambient temperature	°C	40

ml = Max. load · me = Max. efficiency · fa = Running at free air · cs = Customer specs · cu = Customer unit
Subject to alterations

Data according to ErP directive

		Actual	Request 2015		
01 Overall efficiency η_{es}	%	57.5	36.6	09 Power input P_{ed}	kW
02 Measurement category		A		09 Air flow q_v	m ³ /h
03 Efficiency category		Static		09 Pressure increase p_{fs}	Pa
04 Efficiency grade N		64.9	44	10 Speed (rpm) n	min ⁻¹
05 Variable speed drive		Yes		11 Specific ratio [*]	
					1.01

Data definition with optimum efficiency.
The ErP data is determined using a motor-impeller combination in a standardised measurement configuration.

^{*} Specific ratio = $1 + p_{fs} / 100\,000\text{ Pa}$

LU-113273



EC centrifugal fan

forward curved, dual inlet
with housing (large flange)

Technical features

Mass	17 kg
Size	283 mm
Surface of rotor	Coated in black
Material of electronics housing	Die-cast aluminium
Material of impeller	Sheet steel, galvanised
Housing material	Sheet steel, galvanised
Motor suspension	Motor anti-vibration mounted on both sides
Direction of rotation	Clockwise, seen on rotor
Type of protection	IP 20
Insulation class	"B"
Humidity (F)/environmental protection class (H)	F4-1
Max. permissible ambient motor temp. (transp./ storage)	+80 °C
Min. permissible ambient motor temp. (transp./storage)	-40 °C
Mounting position	Shaft horizontal
Cooling bore / aperture	Rotor-side
Operation mode	S1
Motor bearing	Ball bearing
Technical features	<ul style="list-style-type: none"> - PFC, passive - Control input 0-10 VDC / PWM - Output 10 VDC, max. 1.1 mA - Tach output - Over-temperature protected electronics / motor - Alarm relay - Integrated PID controller - RS485 ebmBUS - Motor current limit - Soft start - Line undervoltage / phase failure detection
EMC interference immunity	Acc. to EN 61000-6-2 (industrial environment)
EMC harmonics	Acc. to EN 61000-3-2/3
EMC interference emission	Acc. to EN 61000-6-4 (industrial environment)
Touch current acc. IEC 60990 (measuring network Fig. 4, TN system)	<= 3.5 mA
Motor protection	Thermal overload protector (TOP) wired internally
Cable exit	Variable
Protection class	I (if protective earth is connected by customer)



EC centrifugal fan

forward curved, dual inlet
with housing (large flange)

Product drawing

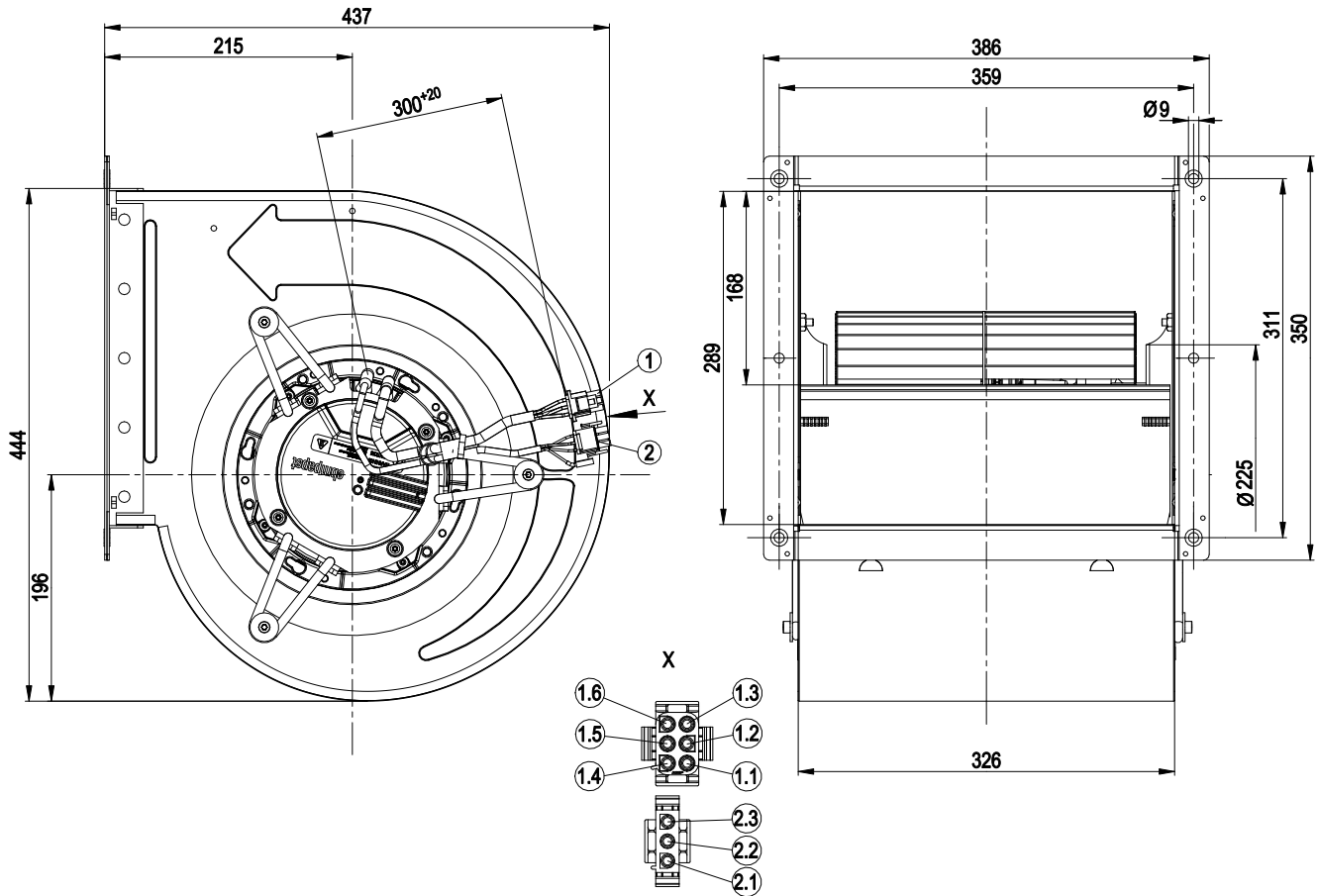

X	View X
1	Connection line AWG 18 with connector housing AMP order No. 350 715-4 with 5 x plug pin AMP order No. 926 883-1
1.1	L1 (black)
1.2	L2 (black)
1.3	L3 (black)
1.4	PE (green / yellow)
1.5	NC (white 1)
1.6	COM (white 2)
2	Connection line AWG 22 with connector housing AMP order No. 350 766-4 with 3 x plug pin AMP order No. 926 885-1
2.1	0-10V / PWM (yellow)
2.2	+10V (red)
2.3	GND (blue)



EC centrifugal fan

forward curved, dual inlet
with housing (large flange)

Connection screen

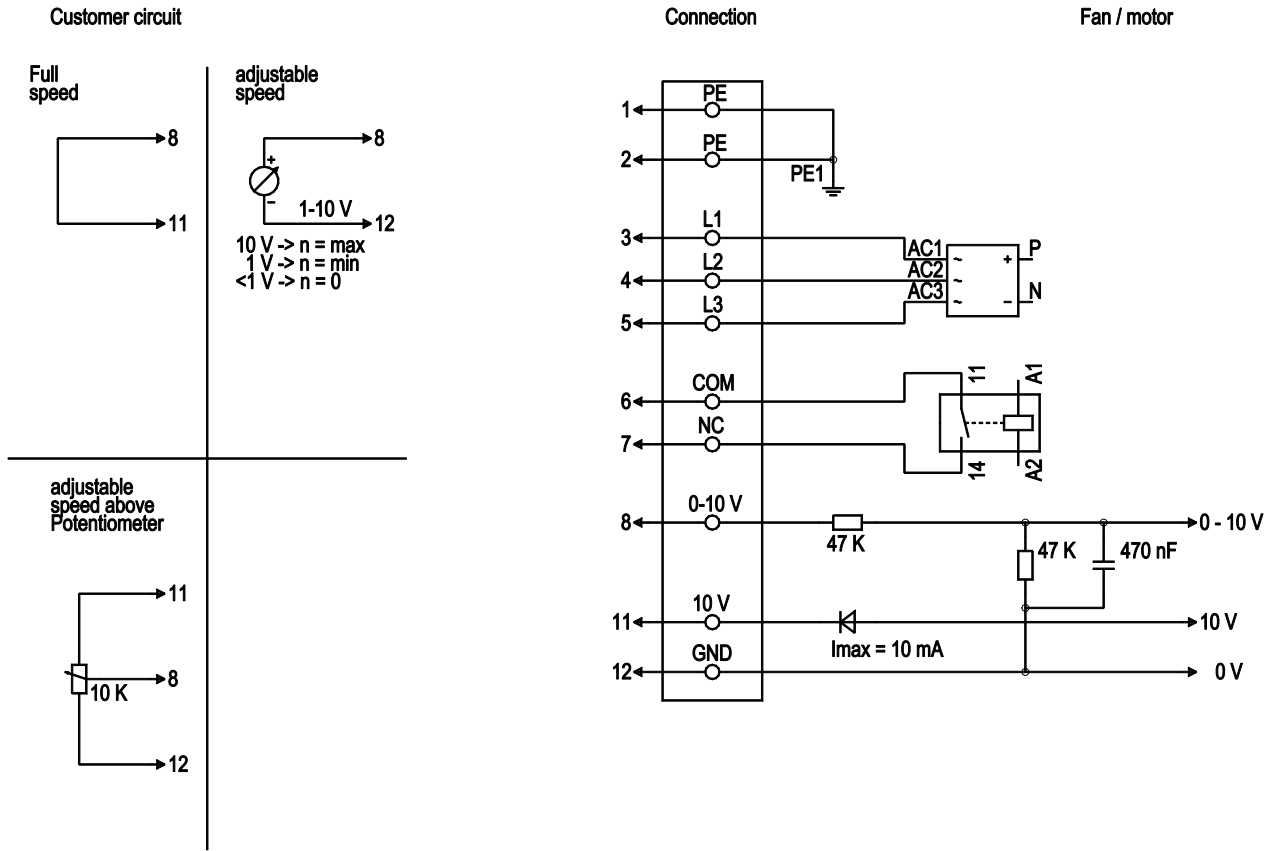

No.	Conn.	Designation	Colour	Function / assignment
1	1, 2	PE	green/yellow	Protective earth
1	3, 4, 5	L1, L2, L3	black	Supply voltage 50 / 60 Hz
1	6	COM	white 1	Floating status contact, break for failure (2 A, max. 250 VAC, min. 10 mA, AC1)
1	7	NC	white 2	Floating status message contact, break for failure
2	8	0 - 10 V	yellow	Control input, set value 0 - 10 VDC, impedance 100 kOhm, SELV
2	11	+ 10 V	red	Voltage output 10 VDC (+/-3%), max. 10 mA, supply voltage for ext. devices (e.g. potentiometer), SELV
2	12	GND	blue	Reference mass for control interface, SELV



EC centrifugal fan

forward curved, dual inlet
with housing (large flange)

Charts: Air flow 50 Hz

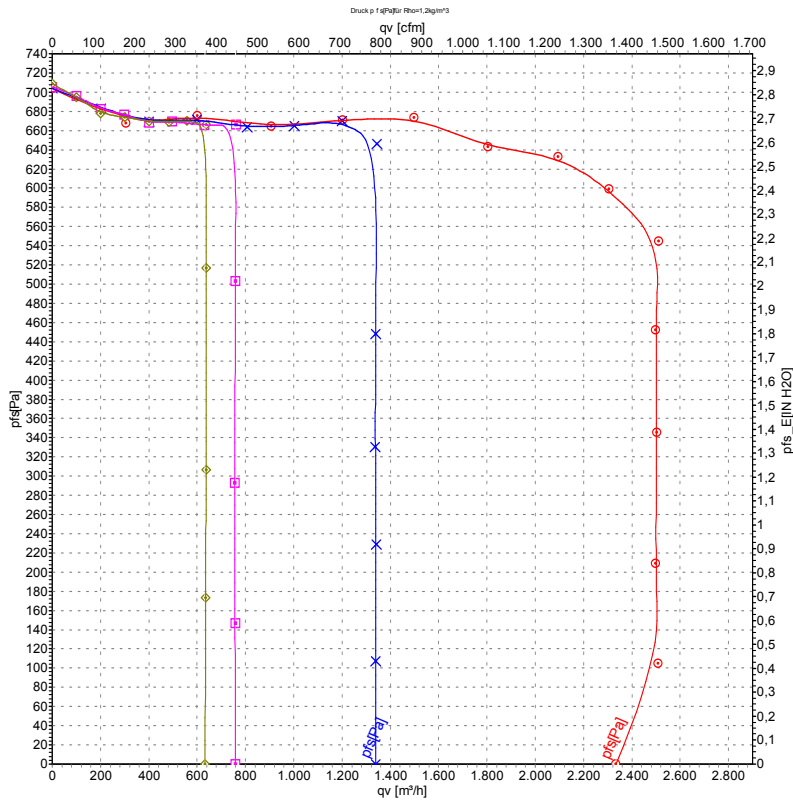

Measurement: LU-113273-1
Measurement: LU-113275-1
Measurement: LU-113277-1
Measurement: LU-113279-1

Air performance measured as per ISO 5801 Installation category A. For detailed information on the measuring set-up, please contact ebm-papst. Suction-side noise levels: L_{WA} measured as per ISO 13347 / L_{pA} measured with 1m distance to fan axis. The values given are valid under the measuring conditions mentioned above and may vary according to the actual installation situation. With any deviation from the standard set-up, the specific values have to be checked and reviewed with the unit installed.

