

D3G250-ED01-71

# EC centrifugal fan

forward curved, dual inlet  
with housing (flange)



D3G250-ED01-71 ebmpapst Datasheet  
sales@fansco.com  
www.fansco.com

Limited partnership · Headquarters Muldingen  
County court Stuttgart · HRA 590344

General partner Elektrobau Muldingen GmbH · Headquarters Muldingen  
County court Stuttgart · HRB 590142

## Nominal data

Type	D3G250-ED01-71	
Motor	M3G084-GF	
Phase		1~
Nominal voltage	VAC	230
Frequency	Hz	50/60
Type of data definition		ml
Speed (rpm)	min <sup>-1</sup>	1085
Power input	W	450
Current draw	A	2.8
Min. back pressure	Pa	100
Min. ambient temperature	°C	-25
Max. ambient temperature	°C	40

ml = Max. load · me = Max. efficiency · fa = Running at free air · cs = Customer specs · cu = Customer unit  
Subject to alterations

## Data in accordance with ecodesign regulation EU 327/2011 (EN 17166)

		Actual	Request 2015		
01 Overall efficiency $\eta_{es}$	%	50.9	34.2	09 Power input $P_{ed}$	kW 0.28
02 Measurement category		A		09 Air flow $q_v$	m <sup>3</sup> /h 1605
03 Efficiency category		Static		09 Pressure increase $p_{fs}$	Pa 292
04 Efficiency grade N		60.7	44	10 Speed (rpm) n	min <sup>-1</sup> 1235
05 Variable speed drive		Yes		11 Specific ratio*	1.00

Data definition with optimum efficiency.  
The ErP data is determined using a motor-impeller combination in a standardised measurement configuration.

\* Specific ratio =  $1 + p_{fs} / 100\,000\text{ Pa}$

LU-109916



# EC centrifugal fan

forward curved, dual inlet  
with housing (flange)

## Technical features

Mass	12.9 kg
Size	250 mm
Motor size	84
Surface of rotor	Coated in black
Material of electronics housing	Die-cast aluminum
Material of impeller	Sheet steel, hot-galvanised
Housing material	Sheet steel, hot-galvanised
Motor suspension	Motor anti-vibration mounted on one side via brackets
Direction of rotation	Clockwise, seen on rotor
Type of protection	IP54
Insulation class	"B"
Humidity (F) / environmental protection class (H)	H1
Max. permissible ambient motor temp. (transp./ storage)	+80 °C
Min. permissible ambient motor temp. (transp./storage)	-40 °C
Mounting position	Shaft horizontal
Condensation drainage holes	None
Operation mode	S1
Motor bearing	Ball bearing
Technical features	<ul style="list-style-type: none"> <li>- Output 10 VDC, max. 1.1 mA</li> <li>- Alarm relay</li> <li>- Motor current limit</li> <li>- Soft start</li> <li>- Control input 0-10 VDC / PWM</li> <li>- Control interface with SELV potential safely disconnected from the mains</li> <li>- Over-temperature protected electronics / motor</li> <li>- Line undervoltage detection</li> </ul>
Touch current acc. IEC 60990 (measuring network Fig. 4, TN system)	<= 3.5 mA
Motor protection	Thermal overload protector (TOP) wired internally
Cable exit	Variable
Protection class	I (if protective earth is connected by customer)
Product conforming to standard	EN 61800-5-1; CE
Approval	EAC



# EC centrifugal fan

forward curved, dual inlet  
with housing (flange)

## Product drawing

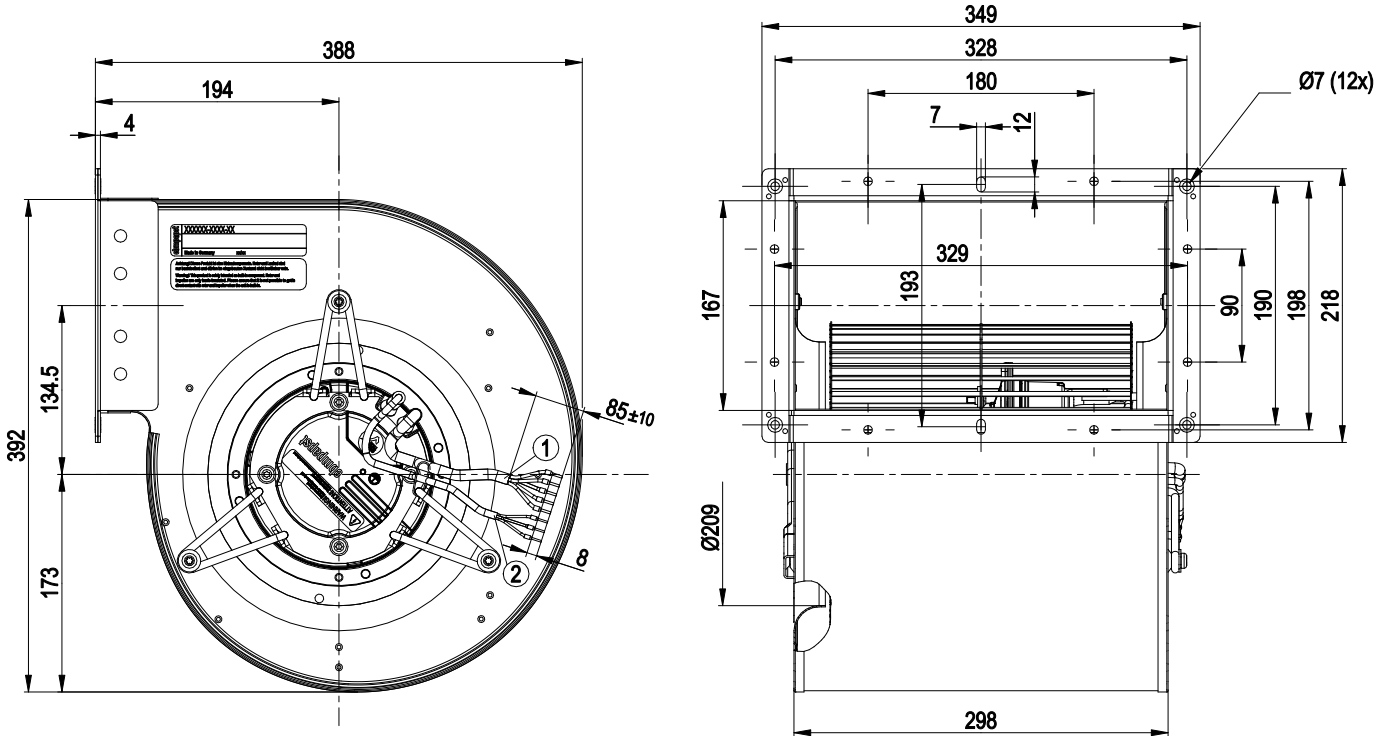

Cable length from electronics enclosure: 800+20 mm

- |   |  |
|---|--|
| 1 | Connection line PVC AWG18, 5x crimped core-end sleeves |
| 2 | Connection line PVC AWG22, 3x crimped core-end sleeves |



# EC centrifugal fan

forward curved, dual inlet  
with housing (flange)

## Connection screen

### Customer circuit

Notes on various control possibilities and their applications

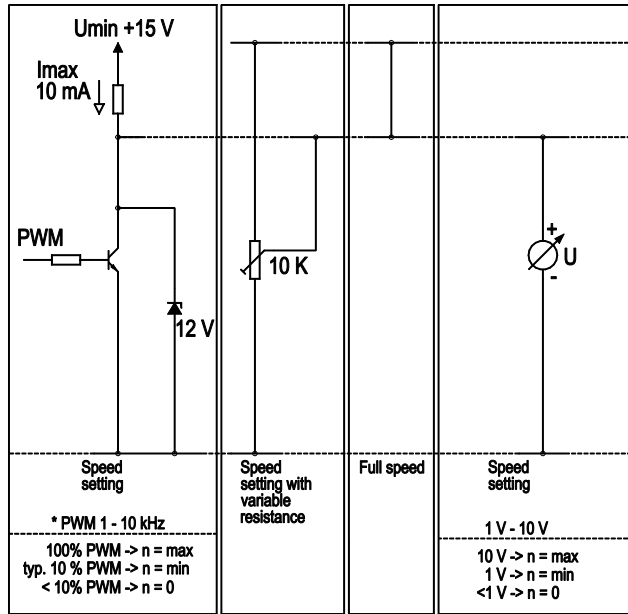

### Connection

### Fan / motor

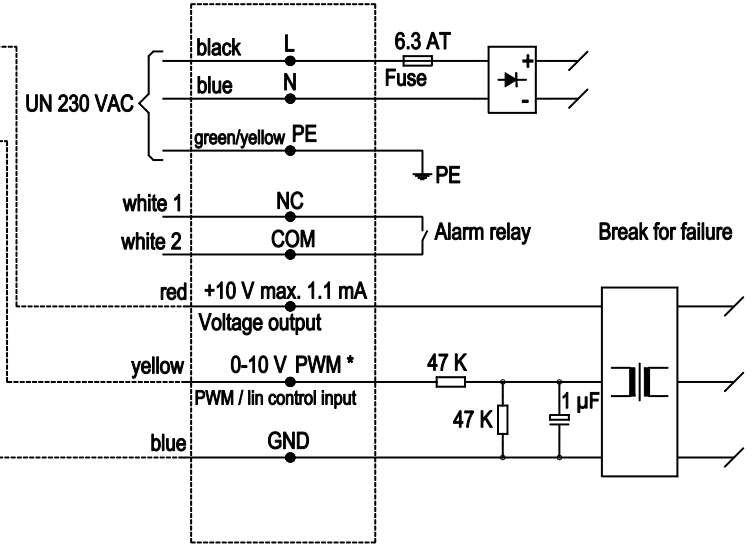

## Charts: Air flow 50 Hz

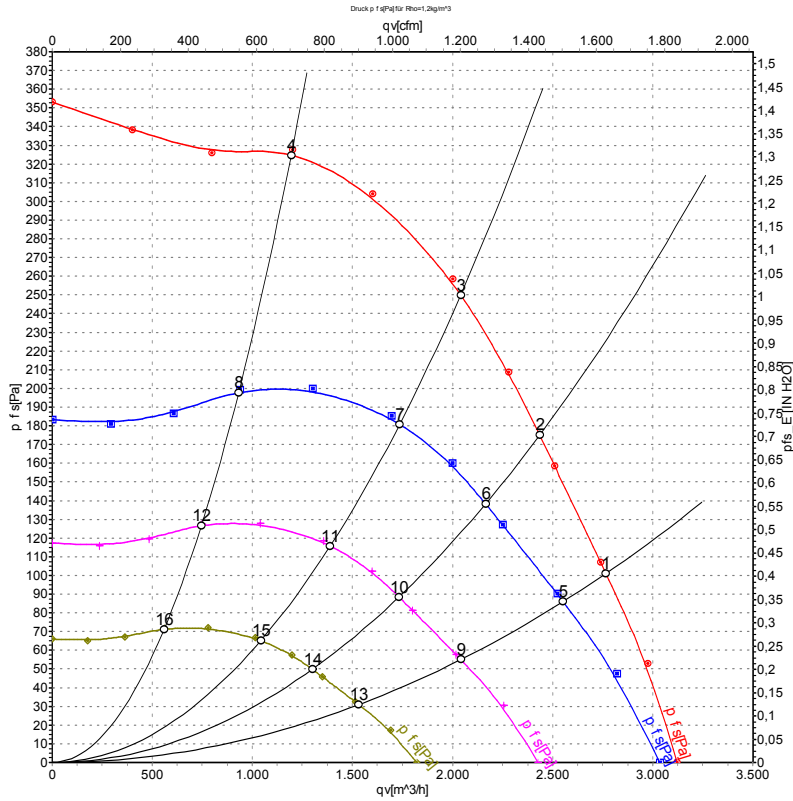

Measurement: LU-109916-1

Air performance measured as per ISO 5801 Installation category A. For detailed information on the measuring set-up, please contact ebmpapst. Suction-side noise levels: LwA measured as per ISO 13347 / LpA measured with 1m distance to fan axis. The values given are valid under the measuring conditions mentioned above and may vary according to the actual installation situation. With any deviation from the standard set-up, the specific values have to be checked and reviewed with the unit installed.

## Measured values

	U	f	n	P <sub>ed</sub>	I	LpA <sub>in</sub>	q <sub>v</sub>	P <sub>fs</sub>	q <sub>v</sub>	P <sub>fs</sub>
	V	Hz	min <sup>-1</sup>	W	A	dB(A)	m <sup>3</sup> /h	Pa	cfm	in. wg
1	230	50	1085	450	2.80	71	2765	100	1625	0.40
2	230	50	1125	401	2.55	69	2435	175	1435	0.70
3	230	50	1175	346	2.20	67	2040	250	1200	1.00
4	230	50	1285	232	1.50	65	1195	325	700	1.30
5	230	50	1000	346	2.21	69	2550	86	1500	0.35
6	230	50	1000	282	1.80	66	2165	138	1275	0.55
7	230	50	1000	213	1.36	63	1735	182	1020	0.73
8	230	50	1000	110	0.71	58	930	199	550	0.80
9	230	50	800	177	1.13	63	2040	55	1200	0.22
10	230	50	800	145	0.92	60	1730	88	1020	0.35
11	230	50	800	109	0.70	56	1390	116	815	0.47
12	230	50	800	56	0.37	52	745	127	440	0.51
13	230	50	600	75	0.48	55	1530	31	900	0.12
14	230	50	600	61	0.39	51	1300	50	765	0.20
15	230	50	600	46	0.29	48	1040	66	615	0.26
16	230	50	600	24	0.15	44	560	72	330	0.29

U = Supply voltage · f = Frequency · n = Speed (rpm) · P<sub>ed</sub> = Power input · I = Current draw · LpA<sub>in</sub> = Sound pressure level inlet side · q<sub>v</sub> = Air flow · p<sub>fs</sub> = Pressure increase

