

D3G200-BB22-71

EC centrifugal fan

forward curved, dual inlet
with housing (flange)



D3G200-BB22-71 ebmpapst Datasheet

sales@fansco.com

www.fansco.com

Nominal data

Type	D3G200-BB22-71	
Motor	M3G084-FA	
Phase		1~
Nominal voltage	VAC	230
Nominal voltage range	VAC	207 .. 253
Frequency	Hz	50/60
Type of data definition		ml
Speed	min ⁻¹	1640
Power input	W	465
Current draw	A	3.0
Min. back pressure	Pa	225
Min. ambient temperature	°C	-25
Max. ambient temperature	°C	50

ml = Max. load · me = Max. efficiency · fa = Running at free air · cs = Customer specs · cu = Customer unit
Subject to alterations

Data according to ErP directive

Installation category	A
Efficiency category	Static
Variable speed drive	Yes
Specific ratio*	1.00

* Specific ratio = $1 + p_b / 100\,000\text{ Pa}$

		Actual	Request 2013	Request 2015
Overall efficiency η_{es}	%	46.4	27.8	34.8
Efficiency grade N		55.6	37	44
Power input P_{ed}	kW	0.35		
Air flow q_v	m ³ /h	1510		
Pressure increase p_{fs}	Pa	351		
Speed n	min ⁻¹	1750		

Data definition with optimum efficiency. LU-107744
The ErP data is determined using a motor-impeller combination in a standardised measurement configuration.



Technical features

Mass	9.4 kg
Size	200 mm
Surface of rotor	Coated in black
Material of electronics housing	Die-cast aluminum
Material of impeller	Sheet steel, galvanised
Housing material	Sheet steel, galvanised
Motor suspension	Motor anti-vibration mounted on one side via brackets
Direction of rotation	Clockwise, seen on rotor
Type of protection	IP 54
Insulation class	"B"
Humidity class	F3-1
Max. permissible ambient motor temp. (transp./ storage)	+80 °C
Min. permissible ambient motor temp. (transp./storage)	-40 °C
Mounting position	Shaft horizontal
Condensate discharge holes	None
Operation mode	S1
Motor bearing	Ball bearing
Technical features	<ul style="list-style-type: none"> - Output 10 VDC max. 1.1 mA - Alarm relay - Motor current limit - Soft start - Control input 0-10 VDC / PWM - Control interface with SELV potential safely disconnected from the mains - Excess temperature protection for electronics/motor - Line undervoltage detection
EMC interference immunity	Acc. to EN 61000-6-2 (industrial environment)
EMC interference emission	Acc. to EN 61000-6-3 (household environment)
Touch current acc. IEC 60990 (measuring network Fig. 4, TN system)	<= 3.5 mA
Motor protection	Thermal overload protector (TOP) wired internally
Cable exit	Variable
Protection class	I (if protective earth is connected by customer)
Product conforming to standard	EN 61800-5-1; CE
Approval	EAC

D3G200-BB22-71

EC centrifugal fan

forward curved, dual inlet
with housing (flange)

Product drawing

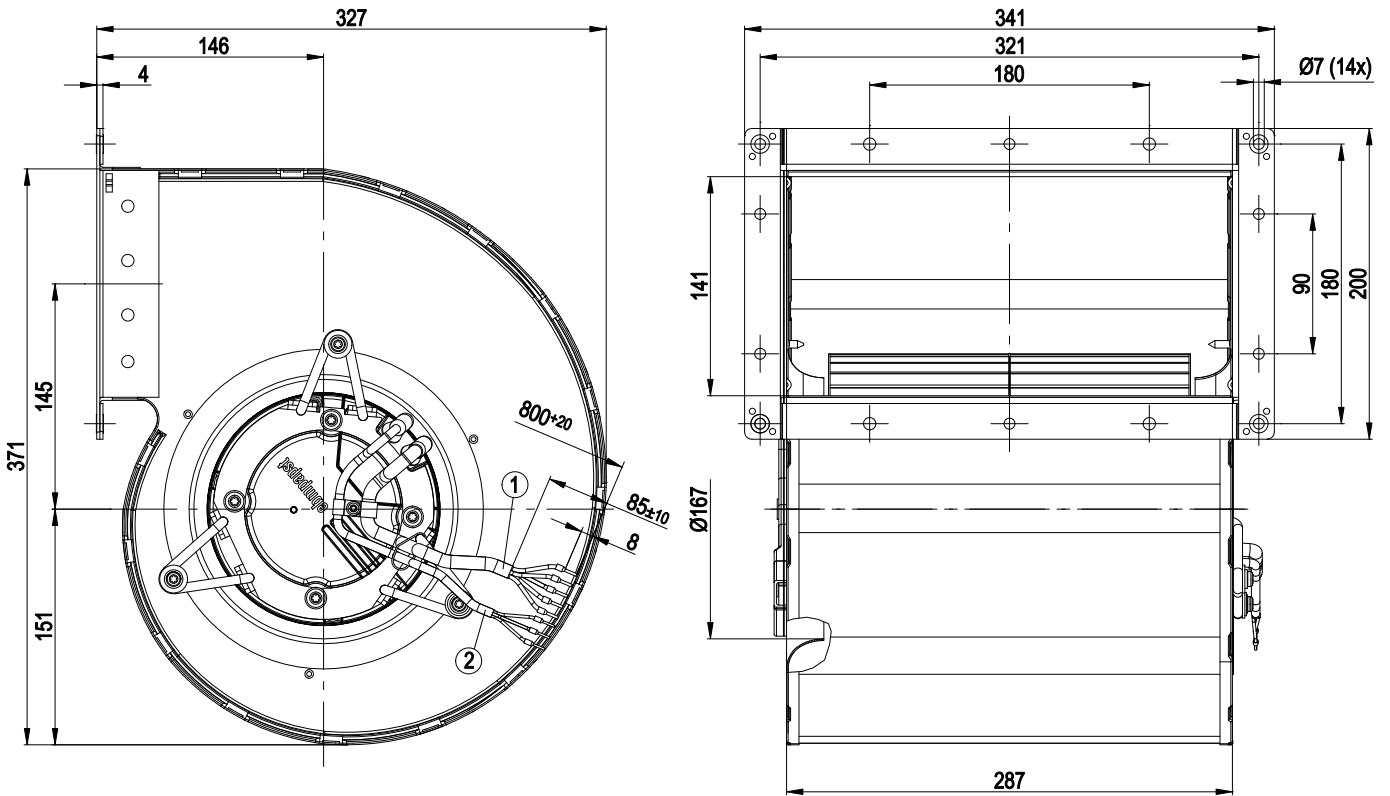

- | | |
|---|--|
| 1 | Connection line PVC AWG18, 5x crimped core-end sleeves |
| 2 | Connection line PVC AWG22, 3x crimped core-end sleeves |



EC centrifugal fan

forward curved, dual inlet
with housing (flange)

Connection screen

Customer circuit

Notes on various control possibilities and their applications

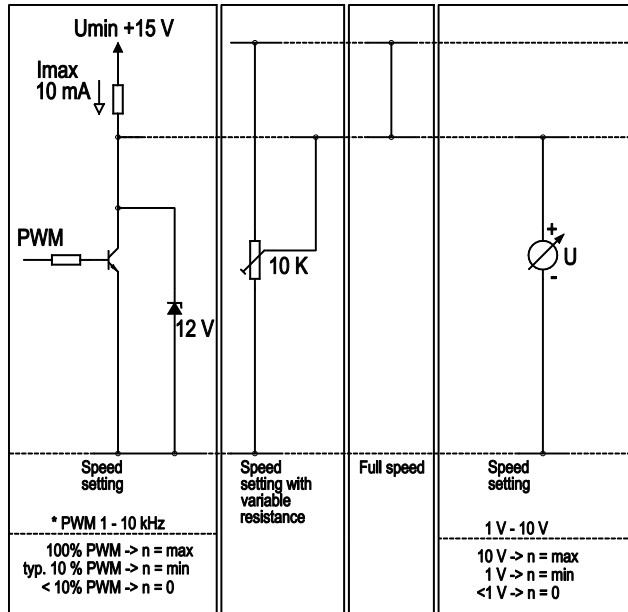

Connection

Fan / motor

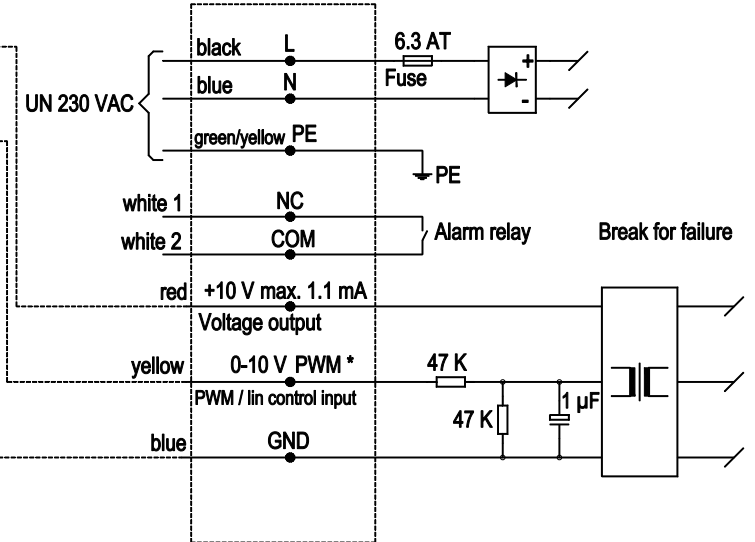

Charts: Air flow

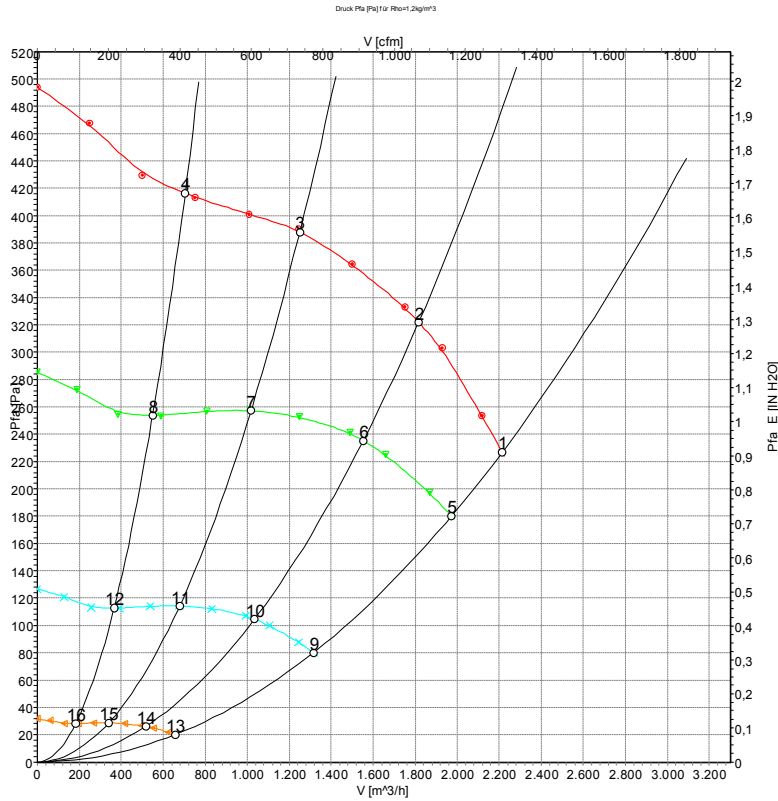

Air performance measured as per ISO 5801 Installation category A. For detailed information on the measuring set-up, please contact ebm-papst. Suction-side noise levels: LwA measured as per ISO 13347 / LpA measured with 1m distance to fan axis. The values given are valid under the measuring conditions mentioned above and may vary according to the actual installation situation. With any deviation from the standard set-up, the specific values have to be checked and reviewed with the unit installed.

Measured values

	U	f	n	P _{ed}	I	LpA _{in}	qv	p _{fs}
	V	Hz	min ⁻¹	W	A	dB(A)	m ³ /h	Pa
1	230	50	1640	465	3.00	70	2215	225
2	230	50	1665	402	2.60	68	1815	320
3	230	50	1750	308	1.98	66	1250	390
4	230	50	1825	225	1.48	66	705	415
5	230	50	1425	337	2.18	68	1975	180
6	230	50	1425	251	1.62	65	1550	235
7	230	50	1425	166	1.07	61	1020	258
8	230	50	1425	107	0.70	61	550	254
9	230	50	950	100	0.65	56	1315	80
10	230	50	950	74	0.48	53	1035	105
11	230	50	950	49	0.32	50	680	115
12	230	50	950	32	0.21	50	365	113
13	230	50	475	12	0.08	37	660	20
14	230	50	475	9.3	0.06	34	520	26
15	230	50	475	6.2	0.04	32	340	29
16	230	50	475	4.0	0.03	32	185	28

U = Supply voltage · f = Frequency · n = Speed · P_{ed} = Power input · I = Current draw · LpA_{in} = Sound pressure level inlet side · qv = Air flow · p_{fs} = Pressure increase

