

EC centrifugal fan

forward curved, dual inlet
with housing (flange)

D3G160-LV13-32 ebmpapst Datasheet
sales@fansco.com
www.fansco.com

Limited partnership · Headquarters Mulfingen
County court Stuttgart · HRA 590344

General partner Elektrobau Mulfingen GmbH · Headquarters Mulfingen
County court Stuttgart · HRB 590142

Nominal data

Type	D3G160-LV13-32	
Motor	M3G055-DF	
Phase		1~
Nominal voltage	VAC	230
Nominal voltage range	VAC	200 .. 240
Frequency	Hz	50/60
Type of data definition		ml
Speed (rpm)	min ⁻¹	1650
Power input	W	170
Current draw	A	1.4
Min. back pressure	Pa	150
Max. ambient temperature	°C	60

ml = Max. load · me = Max. efficiency · fa = Running at free air · cs = Customer specs · cu = Customer unit
Subject to alterations

Data in accordance with ecodesign regulation EU 327/2011

		Actual	Request 2015			
01 Overall efficiency η_{es}	%	42.4	32.6	09 Power input P_{ed}	kW	0.16
02 Measurement category		A		09 Air flow q_v	m ³ /h	705
03 Efficiency category		Static		09 Pressure increase p_{fs}	Pa	317
04 Efficiency grade N		53.8	44	10 Speed (rpm) n	min ⁻¹	2110
05 Variable speed drive		Yes		11 Specific ratio [*]		1.00

Data definition with optimum efficiency.
The ErP data is determined using a motor-impeller combination in a standardised measurement configuration.

^{*} Specific ratio = $1 + p_{fs} / 100\,000\text{ Pa}$

LU-164097



EC centrifugal fan

forward curved, dual inlet
with housing (flange)

Technical features

Mass	3.5 kg
Size	160 mm
Surface of rotor	Galvanised
Material of impeller	Sheet steel, galvanised
Housing material	PP plastic
Motor suspension	Motor mounted vibration-free on both sides
Direction of rotation	Counter-clockwise, seen on rotor
Type of protection	Motor IP34, electronics IP20
Insulation class	"F"
Max. permissible ambient motor temp. (transp./ storage)	+ 80 °C
Min. permissible ambient motor temp. (transp./storage)	- 40 °C
Mounting position	Any
Condensate discharge holes	None, open rotor
Operation mode	S1
Motor bearing	Ball bearing
Technical features	<ul style="list-style-type: none"> - Output 10 VDC, max. 1.1 mA - Fault output (open collector) - Motor current limit - Soft start - Control input 0-10 VDC / PWM - Control interface with SELV potential safely disconnected from the mains - Over-temperature protected motor
Touch current acc. IEC 60990 (measuring network Fig. 4, TN system)	<= 3.5 mA
Electrical leads	With plug
Motor protection	Thermal overload protector (TOP) wired internally
Cable exit	Variable
Protection class	I (if protective earth is connected by customer)
Product conforming to standard	EN 60335-1; CE



EC centrifugal fan

forward curved, dual inlet
with housing (flange)

Product drawing

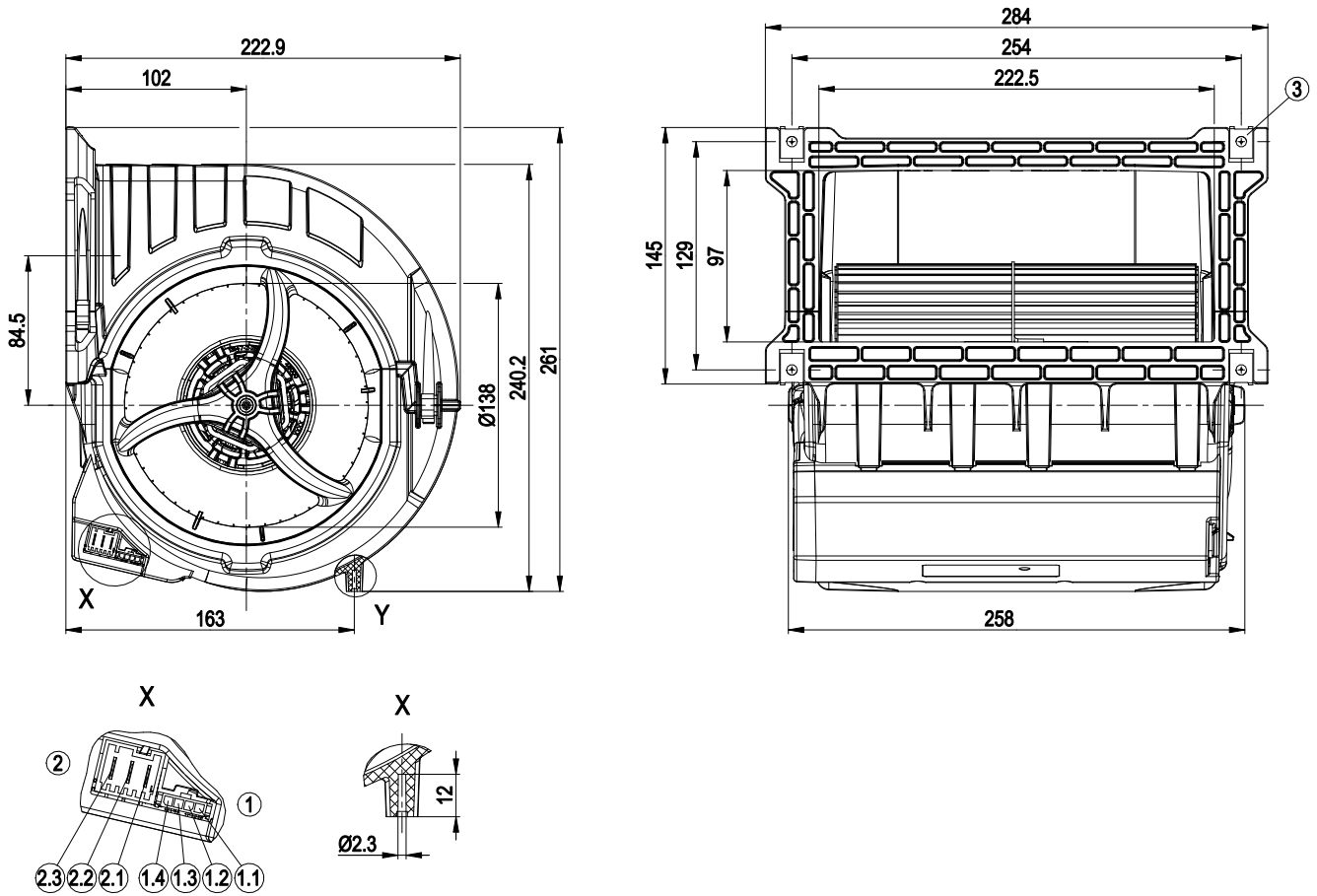

1	Strip Molex Micro Fit 3.0 04365 00400 (pluggable with 04364 50400)
1.1	10 V
1.2	Fan good / fan bad
1.3	0-10 V lin. / PWM
1.4	GND
2	Connector Lumberg 3642 03 K01 (pluggable with 3626 03 K01)
2.1	PE
2.2	L
2.3	N
3	4x sheet metal nut for thread EN ISO 1478-ST4.8 (min. screw length 14.5 mm plus thickness of mounting material)



EC centrifugal fan

forward curved, dual inlet
with housing (flange)

Connection screen

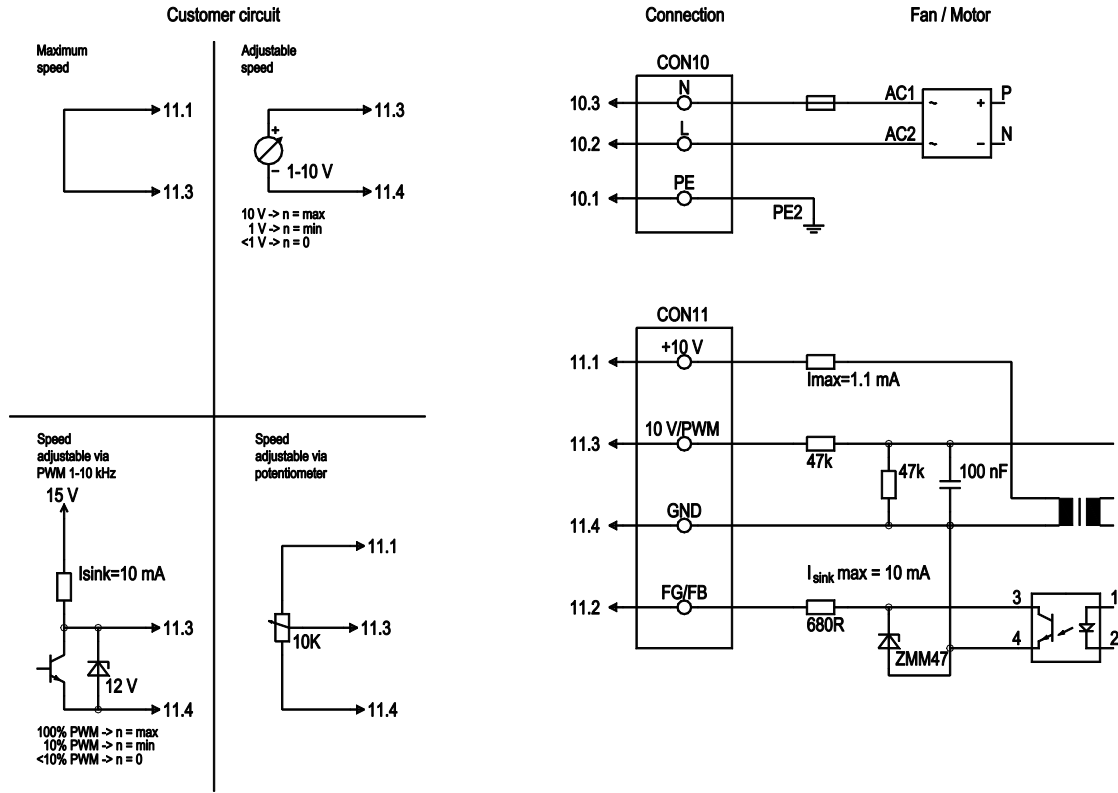

No.	Conn.	Designation	Colour	Function / assignment
CON10	10.1	PE	green/yellow	Protective earth
CON10	10.2	L	black	Power supply 230 VAC, 50-60 Hz, see type plate for voltage range
CON10	10.3	N	blue	Neutral conductor
CON11	11.1	10 V/max. 1.1 mA	red	Voltage output 10 V, 1.1 mA, electrically isolated, not short-circuit-proof
CON11	11.2	FG/FB	white	Fan good / fan bad: Open collector, fan good = low, electrically isolated, Isink max=10 mA
CON11	11.3	0-10 V PWM	yellow	Control input 0-10 V or PWM, electrically isolated
CON11	11.4	GND	blue	GND connection for control interface



EC centrifugal fan

forward curved, dual inlet
with housing (flange)

Charts: Air flow 50 Hz

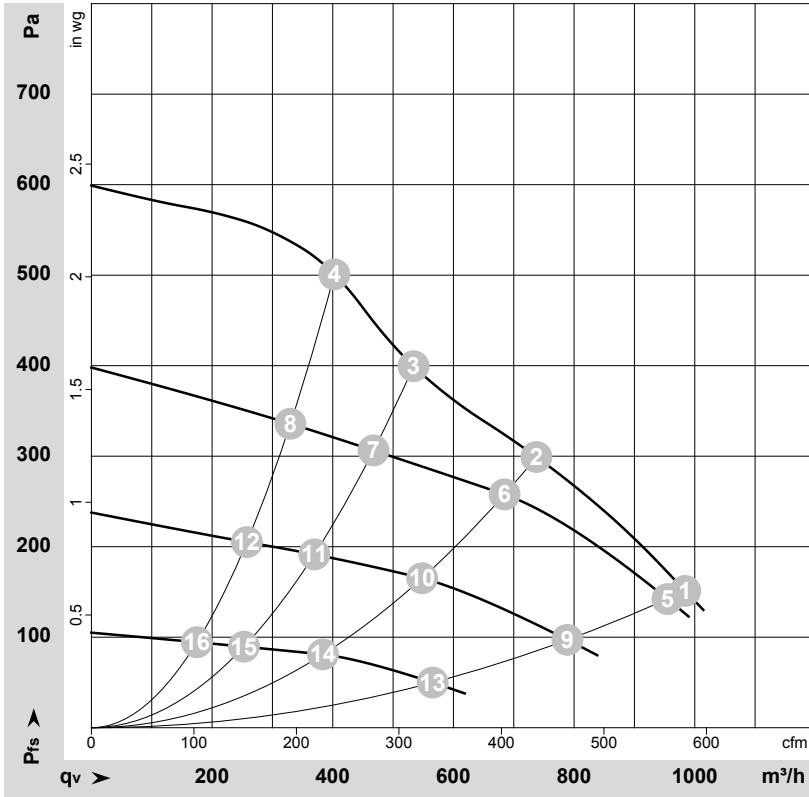

$\rho = 1.15 \text{ kg/m}^3 \pm 2 \%$

Measurement: LU-164097-1
Measurement: LU-141250-1
Measurement: LU-141251-1
Measurement: LU-141252-1

Air performance measured as per ISO 5801 Installation category A. For detailed information on the measuring set-up, please contact ebmpapst. Suction-side noise levels: LwA measured as per ISO 13347 / LpA measured with 1m distance to fan axis. The values given are valid under the measuring conditions mentioned above and may vary according to the actual installation situation. With any deviation from the standard set-up, the specific values have to be checked and reviewed with the unit installed.

Measured values

	U	f	n	P _{ed}	I	q _v	P _{fs}	q _v	P _{fs}
	V	Hz	min ⁻¹	W	A	m ³ /h	Pa	cfm	inH ₂ O
1	230	50	1650	170	1.40	985	150	580	0.60
2	230	50	2060	170	1.40	740	300	435	1.20
3	230	50	2350	170	1.40	535	400	315	1.61
4	230	50	2615	170	1.40	405	500	235	2.01
5	230	50	1630	154	1.25	955	152	560	0.61
6	230	50	1880	130	1.06	685	258	405	1.04
7	230	50	2030	106	0.87	470	307	275	1.23
8	230	50	2135	90	0.74	330	336	195	1.35
9	230	50	1350	82	0.71	790	102	465	0.41
10	230	50	1495	61	0.53	550	165	325	0.66
11	230	50	1595	49	0.43	370	192	220	0.77
12	230	50	1665	40	0.36	260	205	150	0.82
13	230	50	975	29	0.28	565	53	335	0.21
14	230	50	1050	21	0.21	385	81	225	0.33
15	230	50	1090	17	0.18	255	90	150	0.36
16	230	50	1125	14	0.15	175	94	105	0.38

U = Supply voltage · f = Frequency · n = Speed (rpm) · P_{ed} = Power input · I = Current draw · q_v = Air flow · P_{fs} = Pressure increase

