

EC centrifugal fan

forward curved, dual inlet
with housing (flange)

D3G160-BP03-15 ebmpapst Datasheet

sales@fansco.com

www.fansco.com

Nominal data

Type	D3G160-BP03-15	
Motor	M3G055-DF	
Phase		1~
Nominal voltage	VAC	230
Nominal voltage range	VAC	200 .. 240
Frequency	Hz	50/60
Type of data definition		ml
Speed	min ⁻¹	1170
Power input	W	83
Current draw	A	0.7
Min. back pressure	Pa	60
Min. ambient temperature	°C	-25
Max. ambient temperature	°C	40

ml = Max. load · me = Max. efficiency · fa = Running at free air · cs = Customer specs · cu = Customer unit
Subject to alterations



EC centrifugal fan

forward curved, dual inlet
with housing (flange)

Technical features

Mass	4.3 kg
Size	160 mm
Surface of rotor	Thick layer passivated
Material of impeller	Sheet steel, galvanised
Housing material	Sheet steel, galvanised
Motor suspension	Motor mounted anti-vibration on both sides
Direction of rotation	Counter-clockwise, seen on rotor
Type of protection	IP 54; Depending on installation and position
Insulation class	"B"
Max. permissible ambient motor temp. (transp./ storage)	+ 80 °C
Min. permissible ambient motor temp. (transp./storage)	- 40 °C
Mounting position	Shaft horizontal
Condensate discharge holes	None, open rotor
Operation mode	S1
Motor bearing	Ball bearing
Technical features	<ul style="list-style-type: none"> - Output 10 VDC, max. 1.1 mA - Tach output - Motor current limit - Soft start - Control input 0-10 VDC / PWM - Control interface with SELV potential safely disconnected from the mains - Over-temperature protected electronics / motor
EMC interference immunity	Acc. to EN 61000-6-2 (industrial environment)
EMC harmonics	Acc. to EN 61000-3-2/3
EMC interference emission	Acc. to EN 61000-6-3 (household environment)
Touch current acc. IEC 60990 (measuring network Fig. 4, TN system)	<= 3.5 mA
Motor protection	Locked-rotor protection
Protection class	I (if protective earth is connected by customer)
Product conforming to standard	EN 60335-1; CE



EC centrifugal fan

forward curved, dual inlet
with housing (flange)

Product drawing

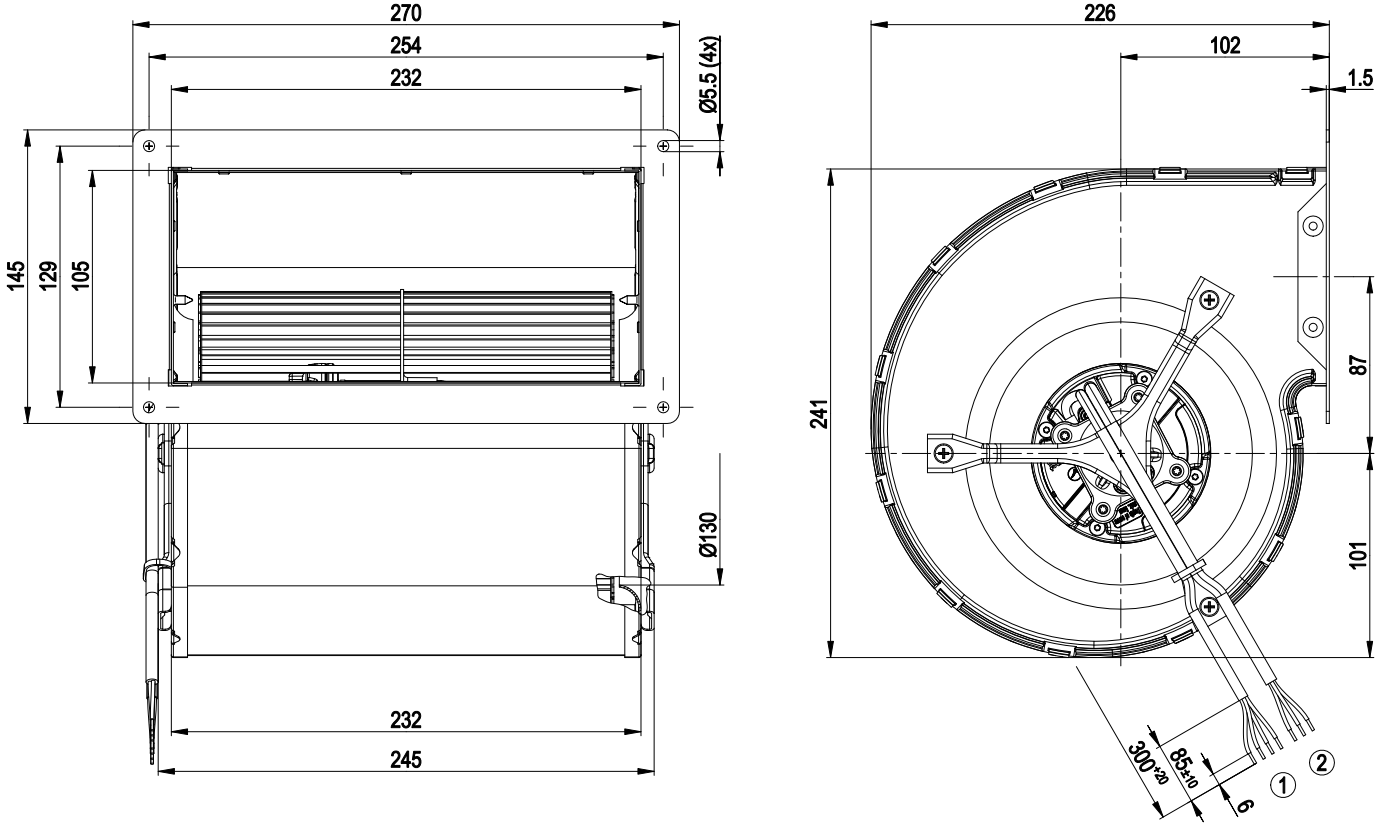

- | | |
|---|---|
| 1 | Connection line PVC AWG22, 4x lead tips crimped |
| 2 | Connection line PVC AWG20, 3x lead tips crimped |



EC centrifugal fan

forward curved, dual inlet
with housing (flange)

Connection screen

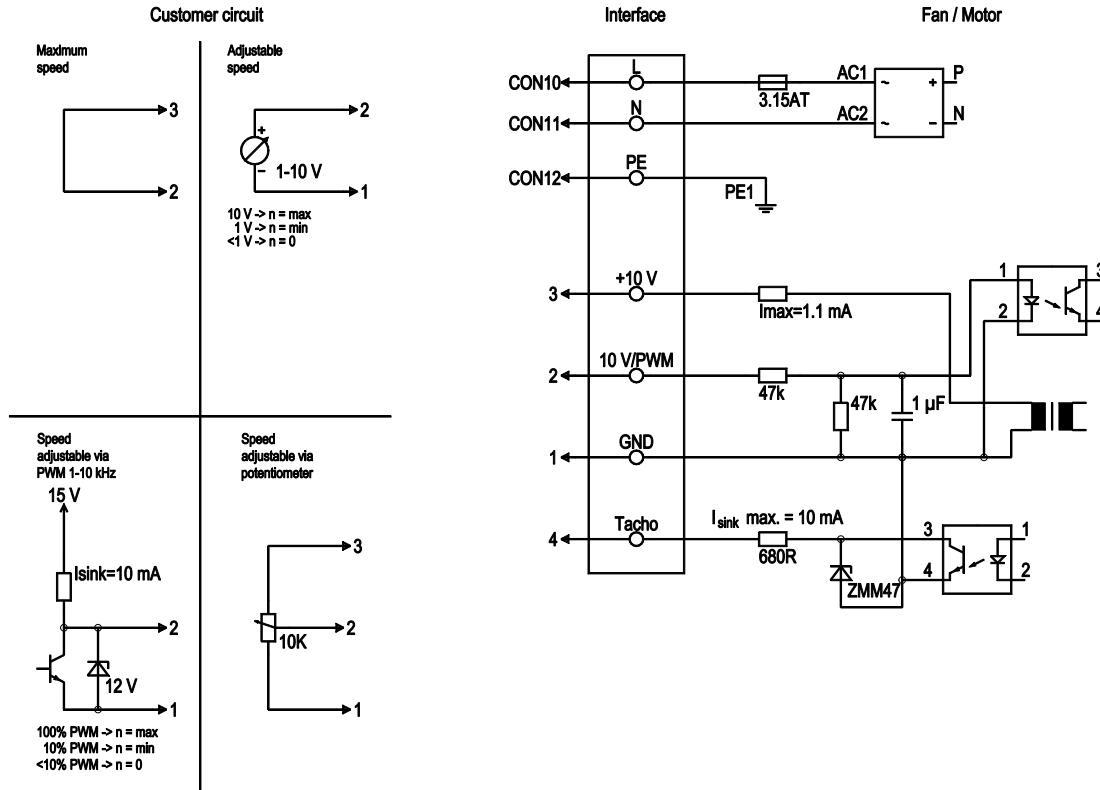

No.	Conn.	Designation	Colour	Function / assignment
	CON10	L	black	Power supply 230 VAC, 50-60 Hz, for voltage range refer to rating plate
	CON11	N	blue	Neutral conductor
	CON12	PE	green/yellow	Protective earth
	1	GND	blue	GND - Connection for control interface
	2	0- 10V PWM	yellow	Control input 0 - 10 V or PWM, electrically isolated
	3	10V/ max 1.1mA	red	Voltage output 10 V / 1.1 mA, electrically isolated, not short-circuit-proof
	4	Tach	white	Tach output: open collector, 1 pulse per revolution, electrically isolated, Isink max = 10 mA



EC centrifugal fan

forward curved, dual inlet

with housing (flange)

Charts: Air flow 50 Hz

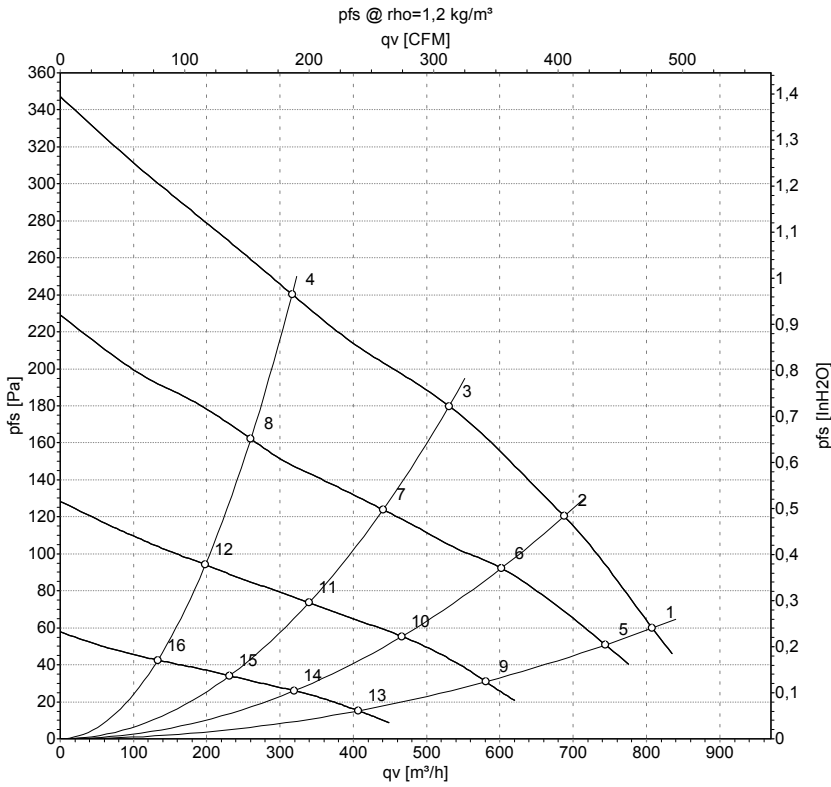

Measurement: LU-150949

Air performance measured as per ISO 5801 Installation category A. For detailed information on the measuring set-up, please contact ebm-papst. Suction-side noise levels: LwA measured as per ISO 13347 / LpA measured with 1m distance to fan axis. The values given are valid under the measuring conditions mentioned above and may vary according to the actual installation situation. With any deviation from the standard set-up, the specific values have to be checked and reviewed with the unit installed.

Measured values

	U	f	n	P _{ed}	I	LpA _{in}	LwA _{in}	qv	p _{fs}
	V	Hz	min ⁻¹	W	A	dB(A)	dB(A)	m ³ /h	Pa
1	230	50	1170	83	0.70	50	62	810	60
2	230	50	1320	83	0.70	51	62	690	120
3	230	50	1495	81	0.69	52	64	530	180
4	230	50	1645	69	0.60	54	66	315	240
5	230	50	1075	66	0.59			745	51
6	230	50	1170	57	0.52			600	93
7	230	50	1265	47	0.44			440	124
8	230	50	1375	39	0.37			260	162
9	230	50	860	33	0.32			580	31
10	230	50	925	28	0.28			465	55
11	230	50	995	23	0.24			340	74
12	230	50	1055	20	0.22			200	94
13	230	50	615	13	0.16			405	15
14	230	50	660	11	0.13			320	26
15	230	50	690	10.0	0.12			230	34
16	230	50	730	8.0	0.11			135	43

U = Supply voltage · f = Frequency · n = Speed · P_{ed} = Power input · I = Current draw · LpA_{in} = Sound pressure level inlet side · LwA_{in} = Sound power level inlet side · qv = Air flow
p_{fs} = Pressure increase

