

# EC centrifugal fan

forward curved, dual inlet

with housing (flange)

D3G146-LV13-37 ebmpapst Datasheet

sales@fansco.com

www.fansco.com

Limited partnership · Headquarters Muldingen  
County court Stuttgart · HRA 590344

General partner Elektrobau Muldingen GmbH · Headquarters Muldingen  
County court Stuttgart · HRB 590142

## Nominal data

Type	D3G146-LV13-37	
Motor	M3G055-DF	
Phase		1~
Nominal voltage	VAC	230
Nominal voltage range	VAC	200 .. 240
Frequency	Hz	50/60
Type of data definition		ml
State		prelim.
Speed (rpm)	min <sup>-1</sup>	1550
Power input	W	167
Current draw	A	1.3
Min. back pressure	Pa	0
Min. ambient temperature	°C	-25
Max. ambient temperature	°C	55

ml = Max. load · me = Max. efficiency · fa = Running at free air · cs = Customer specs · cu = Customer unit  
Subject to alterations

## Data according to ErP directive

		Actual	Request 2015		
01 Overall efficiency $\eta_{es}$	%	35.8	32.6	09 Power input $P_{ed}$	kW
02 Measurement category		A		09 Air flow $q_v$	m <sup>3</sup> /h
03 Efficiency category		Static		09 Pressure increase $p_{fs}$	Pa
04 Efficiency grade N		47.2	44	10 Speed (rpm) n	min <sup>-1</sup>
05 Variable speed drive		Yes		11 Specific ratio*	1.00

Data definition with optimum efficiency.  
The ErP data is determined using a motor-impeller combination in a standardised measurement configuration.

\* Specific ratio =  $1 + p_s / 100\,000\text{ Pa}$

LU-162427



# EC centrifugal fan

forward curved, dual inlet  
with housing (flange)

## Technical features

Mass	2.8 kg
Size	146 mm
Surface of rotor	Galvanised
Material of electronics housing	PP plastic
Material of impeller	Sheet steel, galvanised
Housing material	PP plastic
Motor suspension	Motor mounted anti-vibration on both sides
Direction of rotation	Counter-clockwise, seen on rotor
Type of protection	Motor IP34, electronics IP20
Insulation class	"F"
Max. permissible ambient motor temp. (transp./ storage)	+ 80 °C
Min. permissible ambient motor temp. (transp./storage)	- 40 °C
Mounting position	Any
Cooling bore / aperture	On rotor and stator sides
Operation mode	S1
Motor bearing	Ball bearing
Technical features	<ul style="list-style-type: none"> <li>- Output 10 VDC, max. 1.1 mA</li> <li>- Fault output (open collector)</li> <li>- Motor current limit</li> <li>- Soft start</li> <li>- Control input 0-10 VDC / PWM</li> <li>- Control interface with SELV potential safely disconnected from the mains</li> <li>- Over-temperature protected motor</li> </ul>
Touch current acc. IEC 60990 (measuring network Fig. 4, TN system)	<= 3.5 mA
Electrical leads	With plug
Motor protection	Thermal overload protector (TOP) wired internally
Cable exit	Variable
Protection class	I (if protective earth is connected by customer)
Product conforming to standard	EN 60335-1; CE



# EC centrifugal fan

forward curved, dual inlet  
with housing (flange)

## Product drawing

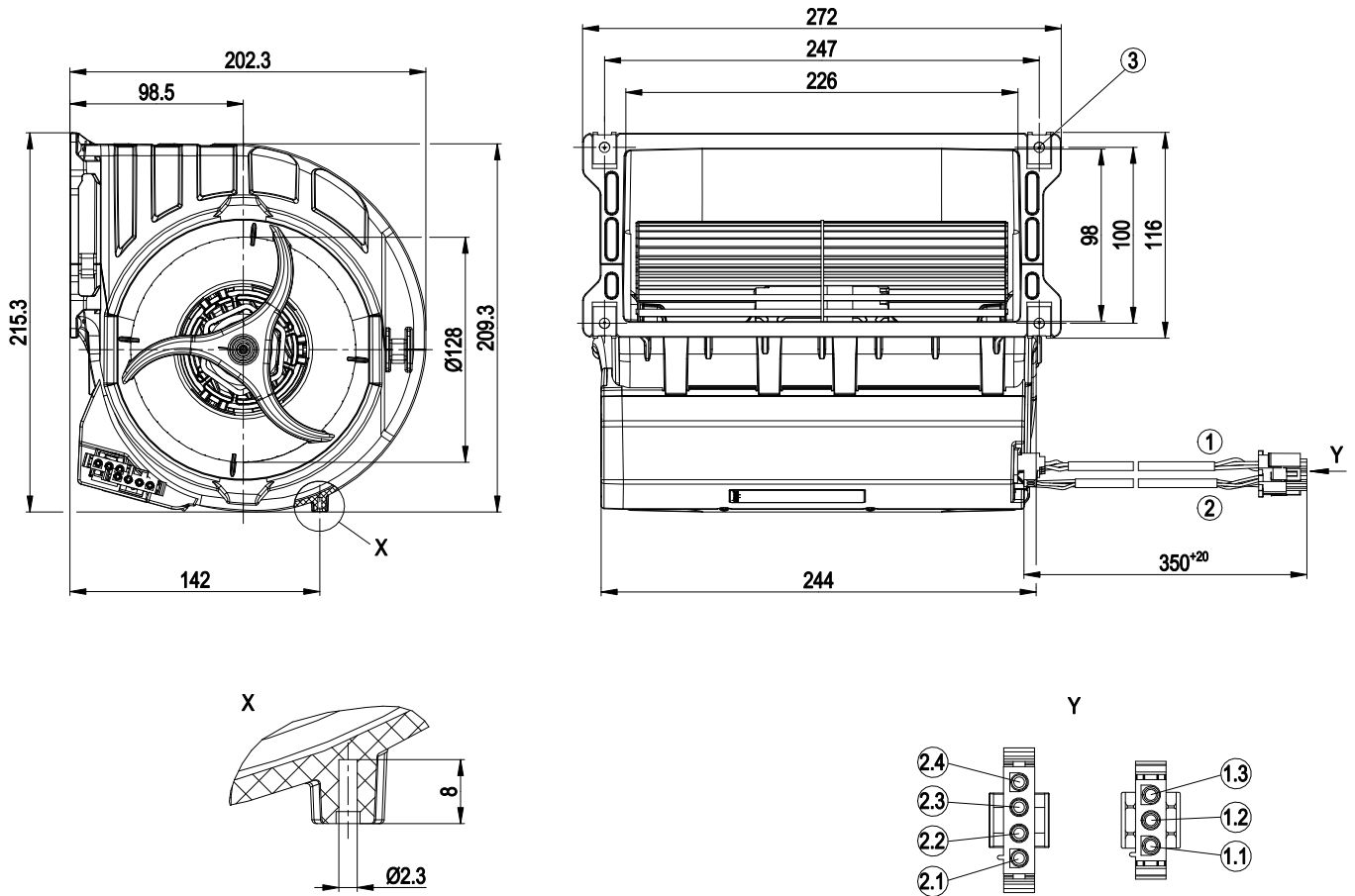

1	Connection line PVC AWG18, tyco 3-pin connector housing 350766-4, 3x tyco plug pin 926883-1
1.1	PE (green/yellow)
1.2	N (blue)
1.3	L (black)
2	Connection line PVC AWG22, connector housing 4-pole Tyco 350779-4, 4x plug pin Tyco 926885-1
2.1	+10 V (red)
2.2	GND (blue)
2.3	0-10 V PWM (yellow)
2.4	Fan good / fan bad (white)
3	4x sheet metal nut for thread EN ISO 1478-ST4.8 (min. screw length 14.5 mm plus thickness of mounting material)



# EC centrifugal fan

forward curved, dual inlet  
with housing (flange)

## Connection screen

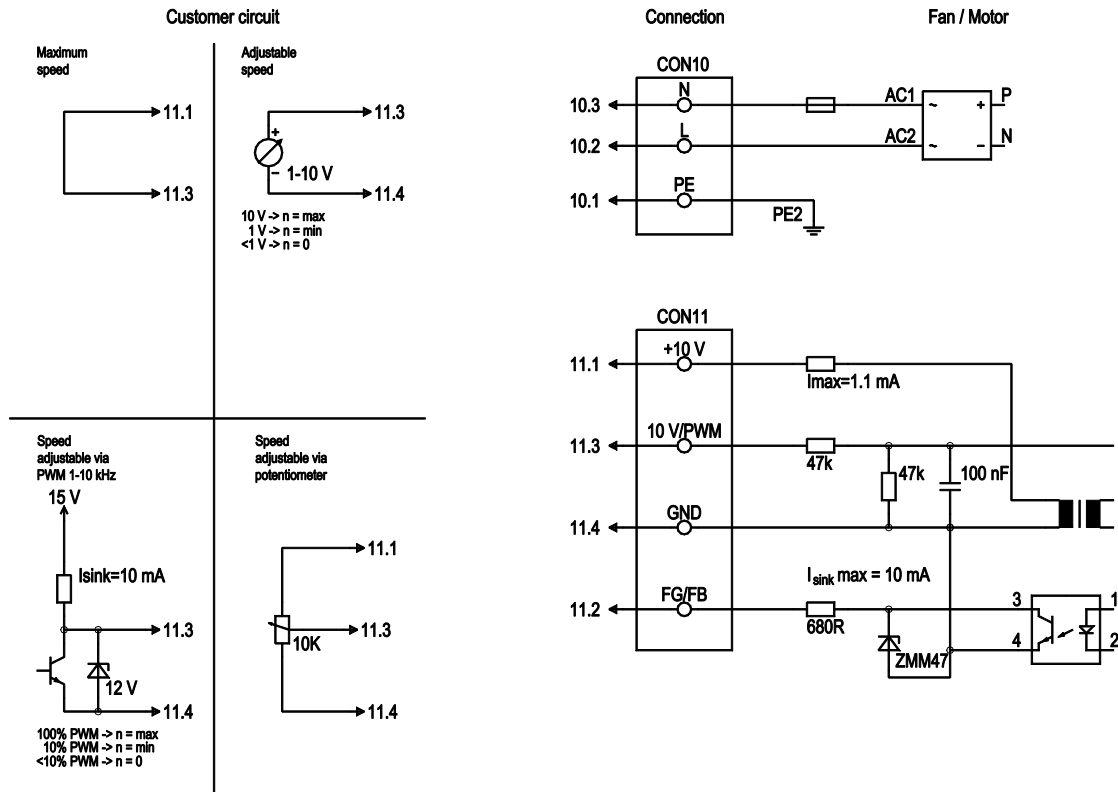

No.	Conn.	Designation	Colour	Function / assignment
CON10	10.1	PE	green/yellow	Protective earth
CON10	10.2	L	black	Power supply 230 VAC, 50-60 Hz, see type plate for voltage range
CON10	10.3	N	blue	Neutral conductor
CON11	11.1	10 V/max. 1.1 mA	red	Voltage output 10 V, 1.1 mA, electrically isolated, not short-circuit-proof
CON11	11.2	FG/FB	white	Fan good / fan bad: Open collector, fan good = high, electrically isolated, Isink max=10 mA
CON11	11.3	0-10 V PWM	yellow	Control input 0-10 V or PWM, electrically isolated
CON11	11.4	GND	blue	GND connection for control interface



# EC centrifugal fan

forward curved, dual inlet  
with housing (flange)

## Charts: Air flow 50 Hz

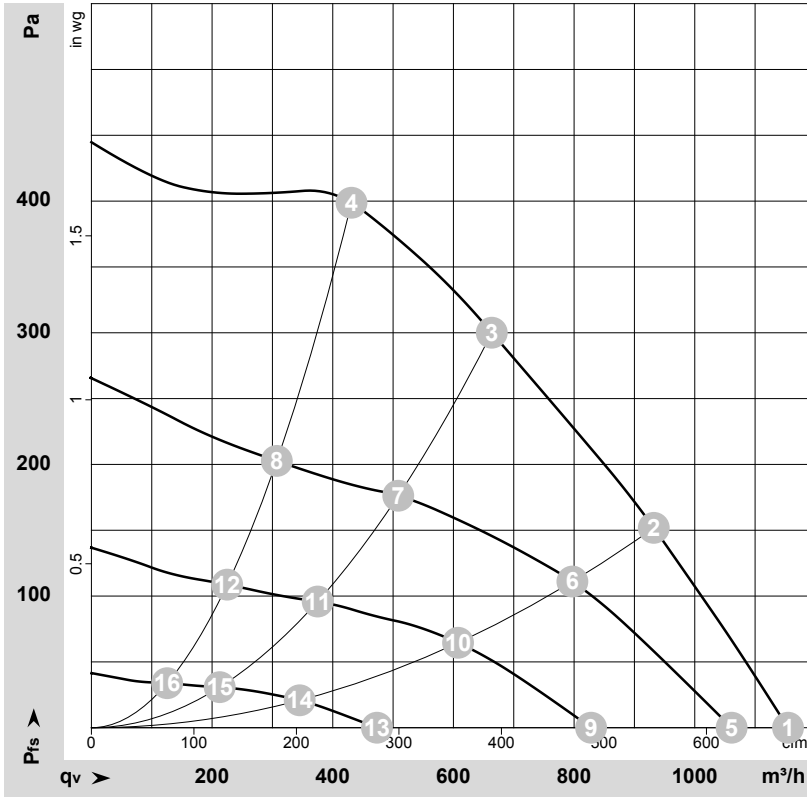

$\rho = 1.15 \text{ kg/m}^3 \pm 2 \%$

Measurement: LU-153304-1  
Measurement: LU-129107-1  
Measurement: LU-129113-1  
Measurement: LU-129114-1

Air performance measured as per ISO 5801 Installation category A. For detailed information on the measuring set-up, please contact ebmpapst. Suction-side noise levels: LwA measured as per ISO 13347 / LpA measured with 1m distance to fan axis. The values given are valid under the measuring conditions mentioned above and may vary according to the actual installation situation. With any deviation from the standard set-up, the specific values have to be checked and reviewed with the unit installed.

## Measured values

	U	f	n	P <sub>ed</sub>	I	LpA <sub>in</sub>	LwA <sub>in</sub>	q <sub>v</sub>	P <sub>fs</sub>	q <sub>v</sub>	P <sub>fs</sub>
	V	Hz	min <sup>-1</sup>	W	A	dB(A)	dB(A)	m <sup>3</sup> /h	Pa	cfm	inH2O
1	230	50	1550	167	1.30	61	74	1155	0	680	0.00
2	230	50	1905	167	1.30	60	72	930	150	550	0.60
3	230	50	2350	167	1.30	62	74	665	300	390	1.20
4	230	50	2675	157	1.25	65	76	430	400	255	1.61
5	230	50	1470	145	1.14			1060	0	625	0.00
6	230	50	1660	110	0.89			795	112	470	0.45
7	230	50	1825	78	0.64			510	177	300	0.71
8	230	50	1935	61	0.51			305	203	180	0.81
9	230	50	1140	63	0.54			830	0	485	0.00
10	230	50	1260	49	0.43			610	65	360	0.26
11	230	50	1345	34	0.30			375	96	220	0.39
12	230	50	1405	27	0.26			225	109	130	0.44
13	230	50	685	16	0.16			475	0	280	0.00
14	230	50	730	12	0.12			345	21	205	0.08
15	230	50	770	9.0	0.11			215	31	125	0.12
16	230	50	800	8.0	0.09			125	34	75	0.14

U = Supply voltage · f = Frequency · n = Speed (rpm) · P<sub>ed</sub> = Power input · I = Current draw · LpA<sub>in</sub> = Sound pressure level inlet side · LwA<sub>in</sub> = Sound power level inlet side · q<sub>v</sub> = Air flow  
P<sub>fs</sub> = Pressure increase

