

# EC centrifugal fan

forward-curved, dual-intake

with housing (flange)

D3G146-HQ13-34 ebmpapst Datasheet

sales@fansco.com

www.fansco.com

## Nominal data

Type	D3G146-HQ13-34	
Motor	M3G055-DF	
Phase		1~
Nominal voltage	VAC	230
Nominal voltage range	VAC	200 .. 240
Frequency	Hz	50/60
Method of obtaining data		ml
Speed (rpm)	min <sup>-1</sup>	2400
Power consumption	W	230
Current draw	A	1.8
Min. ambient temperature	°C	-25
Max. ambient temperature	°C	50

ml = Max. load · me = Max. efficiency · fa = Free air · cs = Customer specification · ce = Customer equipment  
Subject to change

## Data according to Commission Regulation (EU) 327/2011 (EN 17166)

		Actual	Req. 2015			
01 Overall efficiency $\eta_{es}$	%	47.9	32.5	09 Power consumption $P_{ed}$	kW	0.15
02 Measurement category		A		09 Air flow $q_v$	m <sup>3</sup> /h	505
03 Efficiency category		Static		09 Pressure increase $p_{fs}$	Pa	453
04 Efficiency grade N		59.4	44	10 Speed (rpm) $n$	min <sup>-1</sup>	2715
05 Variable speed drive		Yes		11 Specific ratio <sup>*</sup>		1.00

Data obtained at optimum efficiency level.

\* Specific ratio =  $1 + p_g / 100\,000\text{ Pa}$ 

LU-134808

The efficiency values displayed for achieving conformity with the Ecodesign Regulation EU 327/2011 has been reached with defined air duct components (e.g. inlet rings). The dimensions must be requested from ebm-papst. If other air conduction geometries are used on the installation side, the ebm-papst evaluation loses its validity/the conformity must be confirmed again. The product does not fall within the scope of Regulation (EU) 2019/1781 due to the exception specified in Article 2 (2a) (motors completely integrated into a product).



# EC centrifugal fan

forward-curved, dual-intake

with housing (flange)

## Technical description

<b>Weight</b>	2.36 kg
<b>Size</b>	146 mm
<b>Motor size</b>	55
<b>Rotor surface</b>	Galvanized
<b>Electronics housing material</b>	PP plastic
<b>Impeller material</b>	PP plastic
<b>Housing material</b>	PP plastic
<b>Motor suspension</b>	Motor vibration-damped on both sides
<b>Direction of rotation</b>	Counterclockwise, viewed toward rotor
<b>Degree of protection</b>	IP10
<b>Insulation class</b>	"F"
<b>Moisture (F) / Environmental (H) protection class</b>	H0 - dry environment
<b>Max. permitted ambient temp. for motor (transport/storage)</b>	+ 80 °C
<b>Min. permitted ambient temp. for motor (transport/storage)</b>	- 40 °C
<b>Installation position</b>	Any
<b>Condensation drainage holes</b>	None, open rotor
<b>Mode</b>	S1
<b>Motor bearing</b>	Ball bearing
<b>Technical features</b>	<ul style="list-style-type: none"> <li>- Output 10 VDC, max. 1.1 mA</li> <li>- Tach output</li> <li>- Motor current limitation</li> <li>- Soft start</li> <li>- Control input 0-10 VDC / PWM</li> <li>- Control interface with SELV potential safely disconnected from supply</li> <li>- Thermal overload protection for motor</li> </ul>
<b>EMC immunity to interference</b>	According to EN 61000-6-2 (industrial environment)
<b>EMC interference emission</b>	According to EN 61000-6-4 (industrial environment)
<b>Touch current according to IEC 60990 (measuring circuit Fig. 4, TN system)</b>	<= 3.5 mA
<b>Electrical hookup</b>	Plug
<b>Motor protection</b>	Thermal overload protector (TOP) internally connected
<b>With cable</b>	Variable
<b>Protection class</b>	I (with customer connection of protective earth)
<b>Conformity with standards</b>	EN 60335-1; EN 60335-2-31; CE; UKCA
<b>Approval</b>	VDE; CCC; EAC



# EC centrifugal fan

forward-curved, dual-intake  
with housing (flange)

## Product drawing

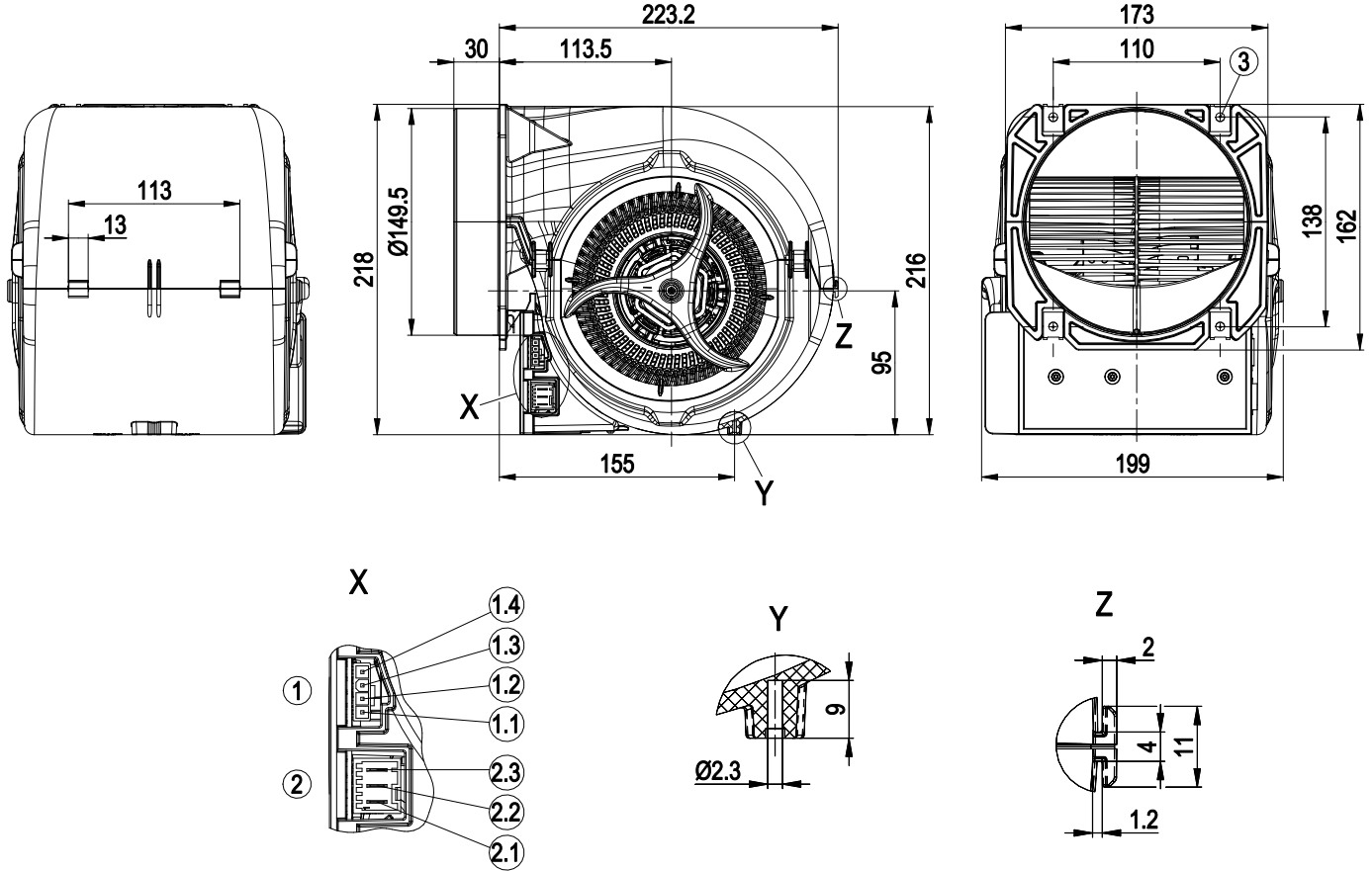

1	Header Stocko MSLO 7708-004-003-960 pluggable with Stocko EH 705-004-003-960 + RBB 8230.120 Ms
1.1	10 V
1.2	Tach
1.3	0-10 V / PWM
1.4	GND
2	Macromodul connector Stocko MSLO 9404-003-00A-960 pluggable with Stocko MFMP 9761-003-50A-960
2.1	L
2.2	N
2.3	PE
3	4x sheet metal nut for thread EN ISO 1478-ST4.8



# EC centrifugal fan

forward-curved, dual-intake  
with housing (flange)

## Connection diagram

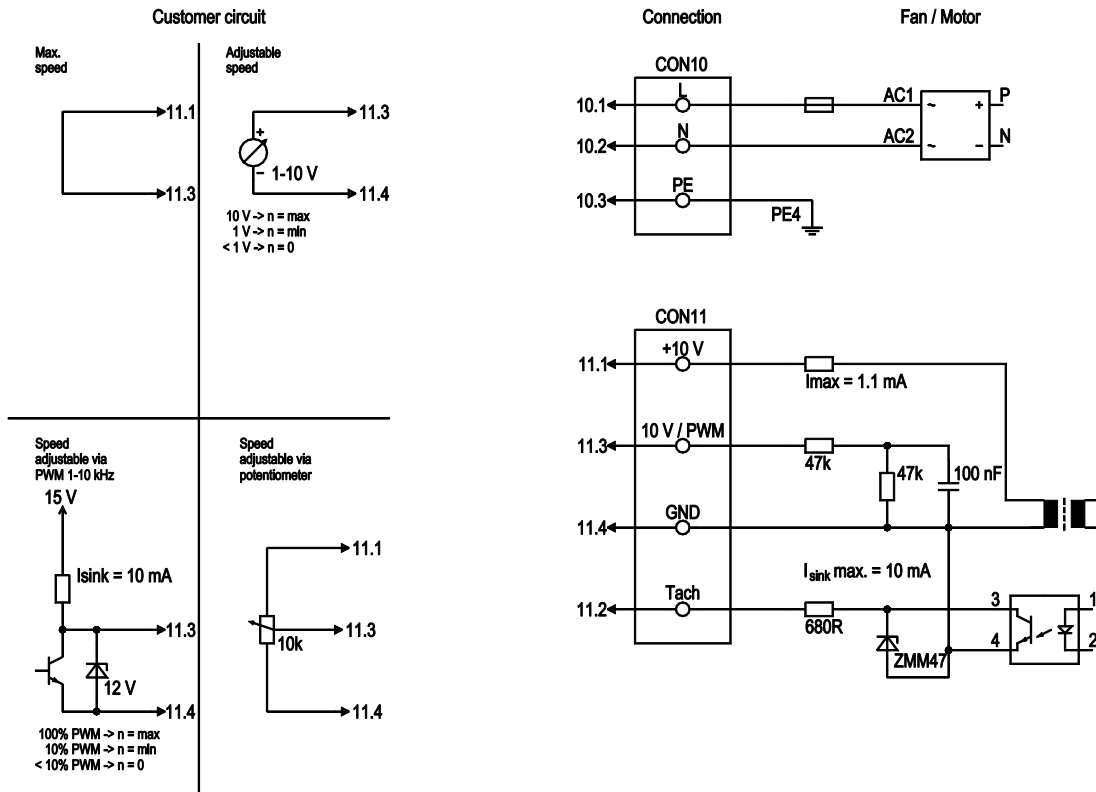

No.	Conn.	Designation	Color	Function/assignment
CON10	10.1	L	black	Power supply 230 VAC, 50-60 Hz, see nameplate for voltage range
CON10	10.2	N	blue	Neutral conductor
CON10	10.3	PE	green/yellow	Protective earth
CON11	11.1	10 V/max. 1.1mA	red	Voltage output 10 V / 1.1 mA, electrically isolated, not short-circuit-proof
CON11	11.2	Tacho	white	Tach output: Open collector, 1 pulse per revolution, electrically isolated, Isink max = 10 mA
CON11	11.3	0-10 V PWM	yellow	Control input 0-10 V or PWM, electrically isolated
CON11	11.4	GND	blue	GND connection for control interface



# EC centrifugal fan

forward-curved, dual-intake

with housing (flange)

## Curves: Air performance 50 Hz

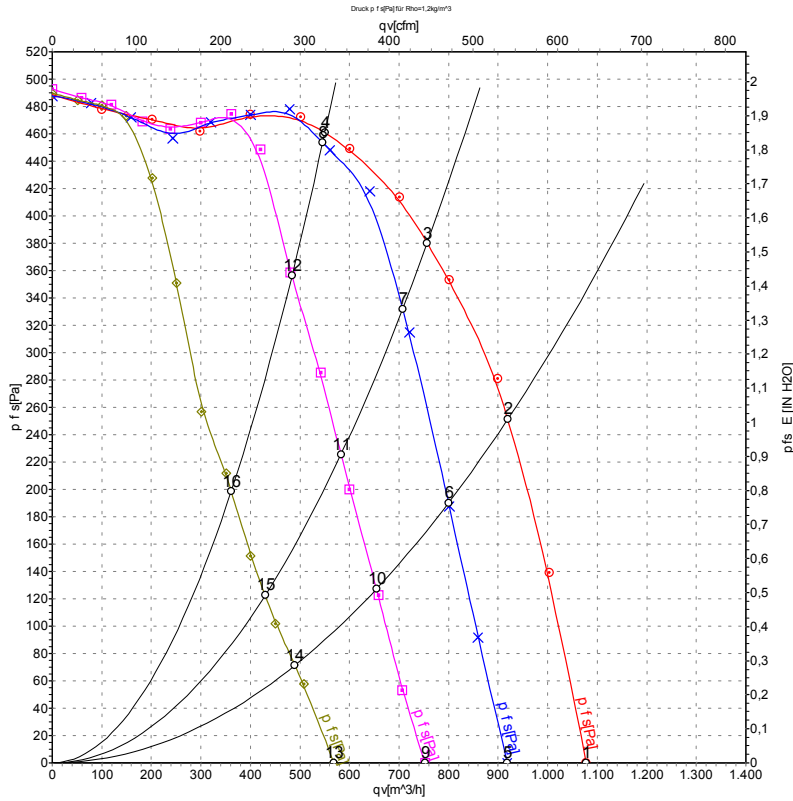

Measurement: LU-134808-1  
 Measurement: LU-132420-1  
 Measurement: LU-132422-1  
 Measurement: LU-132424-1

Air performance measured according to ISO 5801 installation category A. For detailed information on the measurement setup, contact ebmpapst. Intake sound level: Sound power level according to ISO 13347 / sound pressure level measured at 1 m distance from fan axis. The values given are valid under the specified measuring conditions and may vary due to conditions of installation. For deviations from the standard configuration, the parameters have to be checked on the installed unit.

## Measured values

	U	f	n	P <sub>ed</sub>	I	LpA <sub>in</sub>	LwA <sub>in</sub>	q <sub>v</sub>	P <sub>fs</sub>	q <sub>v</sub>	P <sub>fs</sub>
	V	Hz	min <sup>-1</sup>	W	A	dB(A)	dB(A)	m <sup>3</sup> /h	Pa	cfm	in. wg
1	230	50	1790	189	1.47	62	74	1080	0	635	0.00
2	230	50	2400	230	1.80	62	73	920	250	540	1.00
3	230	50	2535	206	1.61	61	72	755	380	445	1.53
4	230	50	2705	164	1.30	61	73	550	460	325	1.85
5	230	50	1535	118	0.97			920	0	540	0.00
6	230	50	2040	154	1.21			800	191	470	0.77
7	230	50	2395	175	1.38			705	333	415	1.34
8	230	50	2695	169	1.33			545	454	320	1.82
9	230	50	1265	66	0.57			750	0	445	0.00
10	230	50	1675	85	0.71			655	128	385	0.51
11	230	50	1975	98	0.82			585	225	345	0.90
12	230	50	2380	118	0.96			485	354	285	1.42
13	230	50	970	29	0.27			570	0	335	0.00
14	230	50	1275	38	0.34			490	72	290	0.29
15	230	50	1490	43	0.37			430	122	255	0.49
16	230	50	1800	52	0.44			360	199	210	0.80

U = Voltage · f = Frequency · n = Speed (rpm) · P<sub>ed</sub> = Power consumption · I = Current draw · LpA<sub>in</sub> = Sound pressure level intake side · LwA<sub>in</sub> = Sound power level intake side  
 q<sub>v</sub> = Air flow · P<sub>fs</sub> = Pressure increase

