

EC centrifugal fan

forward curved, dual inlet

with housing (flange)

D3G146-HQ13-12 ebmpapst Datasheet

sales@fansco.com

www.fansco.com

Limited partnership · Headquarters Mulfingen
County court Stuttgart · HRA 590344

General partner Elektrobau Mulfingen GmbH · Headquarters Mulfingen
County court Stuttgart · HRB 590142



Nominal data

| | | |
|--------------------------|-------------------|------------|
| Type | D3G146-HQ13-12 | |
| Motor | M3G055-DF | |
| Phase | | 1~ |
| Nominal voltage | VAC | 230 |
| Nominal voltage range | VAC | 200 .. 240 |
| Frequency | Hz | 50/60 |
| Type of data definition | | ml |
| Speed (rpm) | min ⁻¹ | 2380 |
| Power input | W | 230 |
| Current draw | A | 1.8 |
| Min. back pressure | Pa | 0 |
| Min. ambient temperature | °C | -25 |
| Max. ambient temperature | °C | 50 |

ml = Max. load · me = Max. efficiency · fa = Running at free air · cs = Customer specs · cu = Customer unit
Subject to alterations

Data according to ErP directive

| | | Actual | Request 2015 | | |
|-----------------------------------|---|--------|--------------|--------------------------------|------------------------|
| 01 Overall efficiency η_{es} | % | 47.9 | 32.5 | 09 Power input P_{ed} | kW 0.15 |
| 02 Measurement category | | A | | 09 Air flow q_v | m ³ /h 505 |
| 03 Efficiency category | | Static | | 09 Pressure increase p_{fs} | Pa 453 |
| 04 Efficiency grade N | | 59.4 | 44 | 10 Speed (rpm) n | min ⁻¹ 2715 |
| 05 Variable speed drive | | Yes | | 11 Specific ratio [*] | 1.00 |

Data definition with optimum efficiency.
The ErP data is determined using a motor-impeller combination in a standardised measurement configuration.

^{*} Specific ratio = $1 + p_{fs} / 100\,000\text{ Pa}$

LU-134808



EC centrifugal fan

forward curved, dual inlet
with housing (flange)

Technical features

| | |
|--|---|
| Mass | 2.4 kg |
| Size | 146 mm |
| Surface of rotor | Galvanised |
| Material of impeller | PP plastic |
| Housing material | PP plastic |
| Motor suspension | Motor mounted anti-vibration on both sides |
| Direction of rotation | Counter-clockwise, seen on rotor |
| Type of protection | IP 20 |
| Insulation class | "F" |
| Max. permissible ambient motor temp. (transp./ storage) | + 80 °C |
| Min. permissible ambient motor temp. (transp./storage) | - 40 °C |
| Mounting position | Any |
| Condensate discharge holes | None, open rotor |
| Operation mode | S1 |
| Motor bearing | Ball bearing |
| Technical features | <ul style="list-style-type: none"> - Speed adjustment input (230 V) - Motor current limit - Soft start - Over-temperature protected motor |
| Touch current acc. IEC 60990 (measuring network Fig. 4, TN system) | <= 3.5 mA |
| Electrical leads | Via terminal box; With plug |
| Motor protection | Thermal overload protector (TOP) wired internally |
| Cable exit | Variable |
| Protection class | I (if protective earth is connected by customer) |
| Product conforming to standard | EN 60335-1; EN 60335-2-31; CE |



EC centrifugal fan

forward curved, dual inlet
with housing (flange)

Product drawing

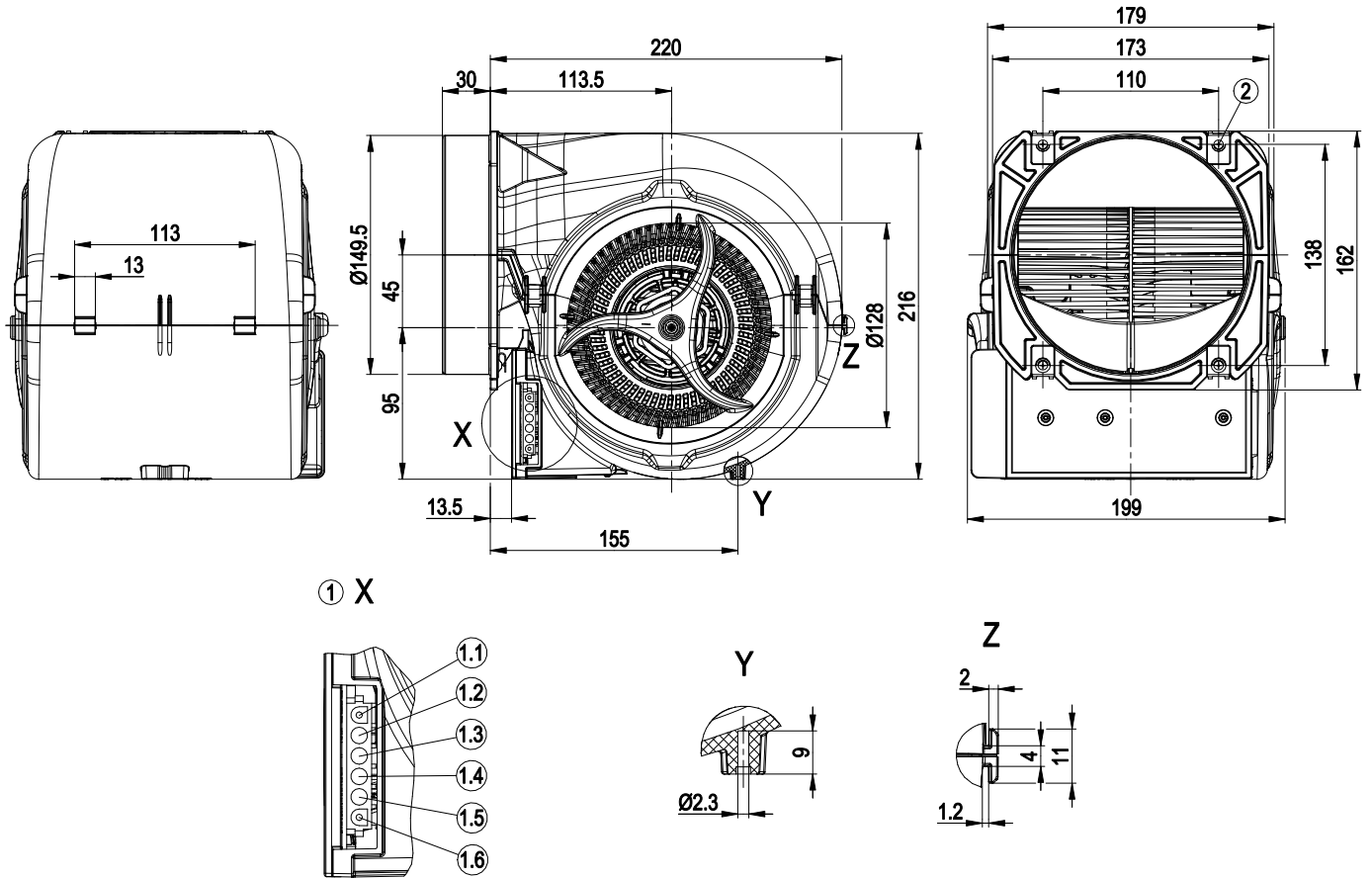

| | |
|-----|---|
| 1 | Pin socket AMP Universal Mate-N-Lok 1586936-1 |
| 1.1 | L = Level 4 (max.) |
| 1.2 | L = Level 3 |
| 1.3 | L = Level 2 |
| 1.4 | L = Level 1 (min.) |
| 1.5 | PE |
| 1.6 | N |
| 2 | 4x sheet metal nut for thread EN ISO 1478-ST4.8 (min. screw length 14.5 mm plus thickness of mounting material) |



EC centrifugal fan

forward curved, dual inlet
with housing (flange)

Connection screen

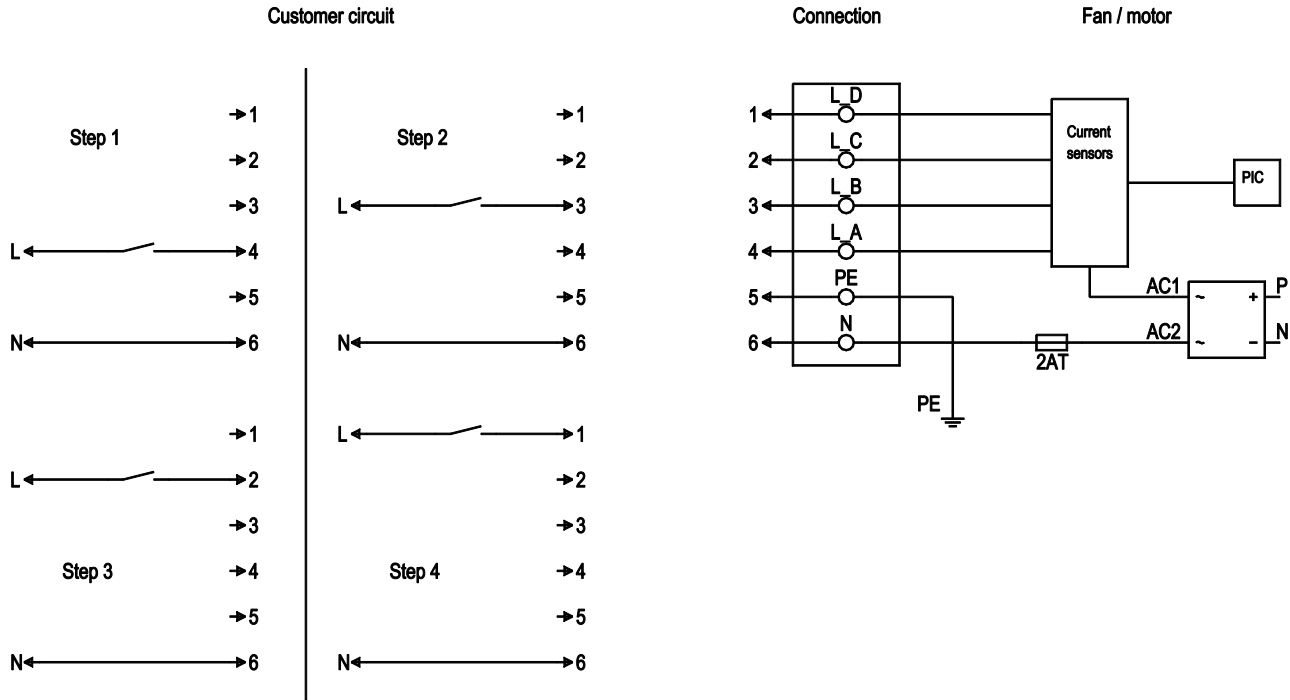

| No. | Conn. | Designation | Colour | Function / assignment |
|-----|-------|-------------|--------------|--|
| | 1 | L_D | black | Step 4 - strongest step (230 VAC, 50-60 Hz, for voltage range refer to rating plate) |
| | 2 | L_C | grey | Step 3 (230 VAC, 50-60 Hz, for voltage range refer to rating plate) |
| | 3 | L_B | red | Step 2 (230 VAC, 50-60 Hz, for voltage range refer to rating plate) |
| | 4 | L_A | white | Step 1 - weakest step (230 VAC, 50-60 Hz, for voltage range refer to rating plate) |
| | 5 | PE | green/yellow | Protective earth |
| | 6 | N | blue | Neutral conductor |



Charts: Air flow 50 Hz

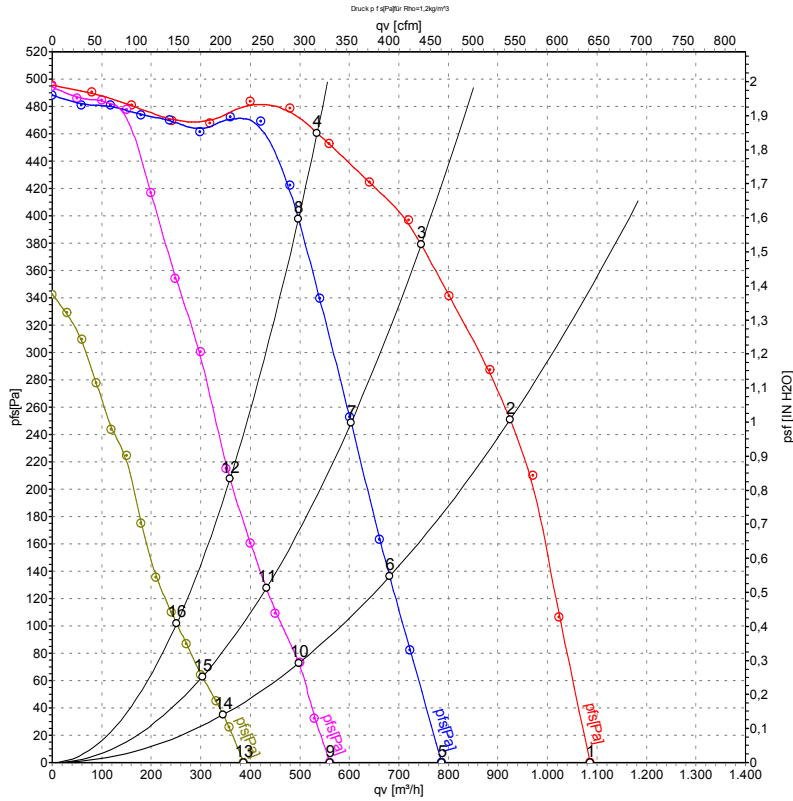

Measurement: LU-138137-1
 Measurement: LU-138138-1
 Measurement: LU-138140-1
 Measurement: LU-138141-1

Air performance measured as per ISO 5801 Installation category A. For detailed information on the measuring set-up, please contact ebmpapst. Suction-side noise levels: LwA measured as per ISO 13347 / LpA measured with 1m distance to fan axis. The values given are valid under the measuring conditions mentioned above and may vary according to the actual installation situation. With any deviation from the standard set-up, the specific values have to be checked and reviewed with the unit installed.

Measured values

| | U | f | n | P _{ed} | I | LpA _{in} | LwA _{in} | qv | p _{fs} | qv | p _{fs} |
|----|-----|----|-------------------|-----------------|------|-------------------|-------------------|------|-----------------|-----|-----------------|
| | V | Hz | min ⁻¹ | W | A | dB(A) | dB(A) | m³/h | Pa | CFM | inH2O |
| 1 | 230 | 50 | 1800 | 193 | 1.35 | 62 | 74 | 1085 | 0 | 640 | 0.00 |
| 2 | 230 | 50 | 2380 | 230 | 1.80 | 62 | 73 | 925 | 250 | 545 | 1.00 |
| 3 | 230 | 50 | 2515 | 196 | 1.42 | 61 | 72 | 745 | 380 | 440 | 1.53 |
| 4 | 230 | 50 | 2690 | 159 | 1.15 | 61 | 72 | 535 | 460 | 315 | 1.85 |
| 5 | 230 | 50 | 1320 | 72 | 0.59 | 55 | 66 | 785 | 0 | 465 | 0.00 |
| 6 | 230 | 50 | 1725 | 90 | 0.73 | 54 | 65 | 680 | 136 | 400 | 0.55 |
| 7 | 230 | 50 | 2050 | 106 | 0.85 | 55 | 66 | 605 | 249 | 355 | 1.00 |
| 8 | 230 | 50 | 2510 | 129 | 1.03 | 59 | 70 | 495 | 399 | 295 | 1.60 |
| 9 | 230 | 50 | 960 | 28 | 0.28 | 47 | 58 | 560 | 0 | 330 | 0.00 |
| 10 | 230 | 50 | 1285 | 39 | 0.35 | 47 | 58 | 500 | 75 | 295 | 0.30 |
| 11 | 230 | 50 | 1500 | 43 | 0.38 | 47 | 59 | 430 | 128 | 255 | 0.51 |
| 12 | 230 | 50 | 1835 | 52 | 0.45 | 51 | 62 | 360 | 206 | 210 | 0.83 |
| 13 | 230 | 50 | 675 | 12 | 0.13 | 38 | 49 | 385 | 0 | 225 | 0.00 |
| 14 | 230 | 50 | 890 | 15 | 0.16 | 38 | 49 | 345 | 35 | 205 | 0.14 |
| 15 | 230 | 50 | 1055 | 17 | 0.18 | 39 | 50 | 305 | 62 | 180 | 0.25 |
| 16 | 230 | 50 | 1305 | 21 | 0.21 | 43 | 54 | 250 | 102 | 150 | 0.41 |

U = Supply voltage · f = Frequency · n = Speed (rpm) · P_{ed} = Power input · I = Current draw · LpA_{in} = Sound pressure level inlet side · LwA_{in} = Sound power level inlet side · qv = Air flow
 p_{fs} = Pressure increase

