

D3G146-HQ01-01

EC centrifugal fan

forward curved, dual inlet
with housing (large flange)



D3G146-HQ01-01 ebmpapst Datasheet
sales@fansco.com
www.fansco.com

Nominal data

Type	D3G146-HQ01-01	
Motor	M3G055-DF	
Phase		1~
Nominal voltage	VAC	230
Nominal voltage range	VAC	200 .. 240
Frequency	Hz	50/60
Type of data definition		ml
Speed	min ⁻¹	1830
Power input	W	165
Current draw	A	1.3
Min. back pressure	Pa	0
Min. ambient temperature	°C	-25
Max. ambient temperature	°C	+50

ml = max. load · me = max. efficiency · fa = running at free air · cs = customer specs · cu = customer unit
Subject to alterations



EC centrifugal fan

forward curved, dual inlet
with housing (large flange)

Technical features

Mass	2.4 kg
Size	146 mm
Surface of rotor	Galvanised
Material of electronics housing	PP plastic, black
Material of impeller	PP plastic, white
Housing material	PP plastic, black
Motor suspension	Motor anti-vibration mounted on both sides
Direction of rotation	Counter-clockwise, seen on rotor
Type of protection	Motor IP54
Insulation class	"F"
Max. permissible ambient motor temp. (transp./ storage)	+ 80 °C
Min. permissible ambient motor temp. (transp./storage)	- 40 °C
Mounting position	Any
Condensate discharge holes	None, open rotor
Operation mode	S1
Motor bearing	Ball bearing
Technical features	<ul style="list-style-type: none"> - Output 10 VDC, max. 1.1 mA - Tach output - Motor current limit - Soft start - Control input 0-10 VDC / PWM - Over-temperature protected motor
Touch current acc. IEC 60990 (measuring network Fig. 4, TN system)	<= 3.5 mA
Electrical leads	With plug; Via terminal box
Motor protection	Thermal overload protector (TOP) wired internally
Cable exit	Variable
Protection class	I (if protective earth is connected by customer)
Product conforming to standard	EN 60335-1; CE



EC centrifugal fan

forward curved, dual inlet
with housing (large flange)

Product drawing

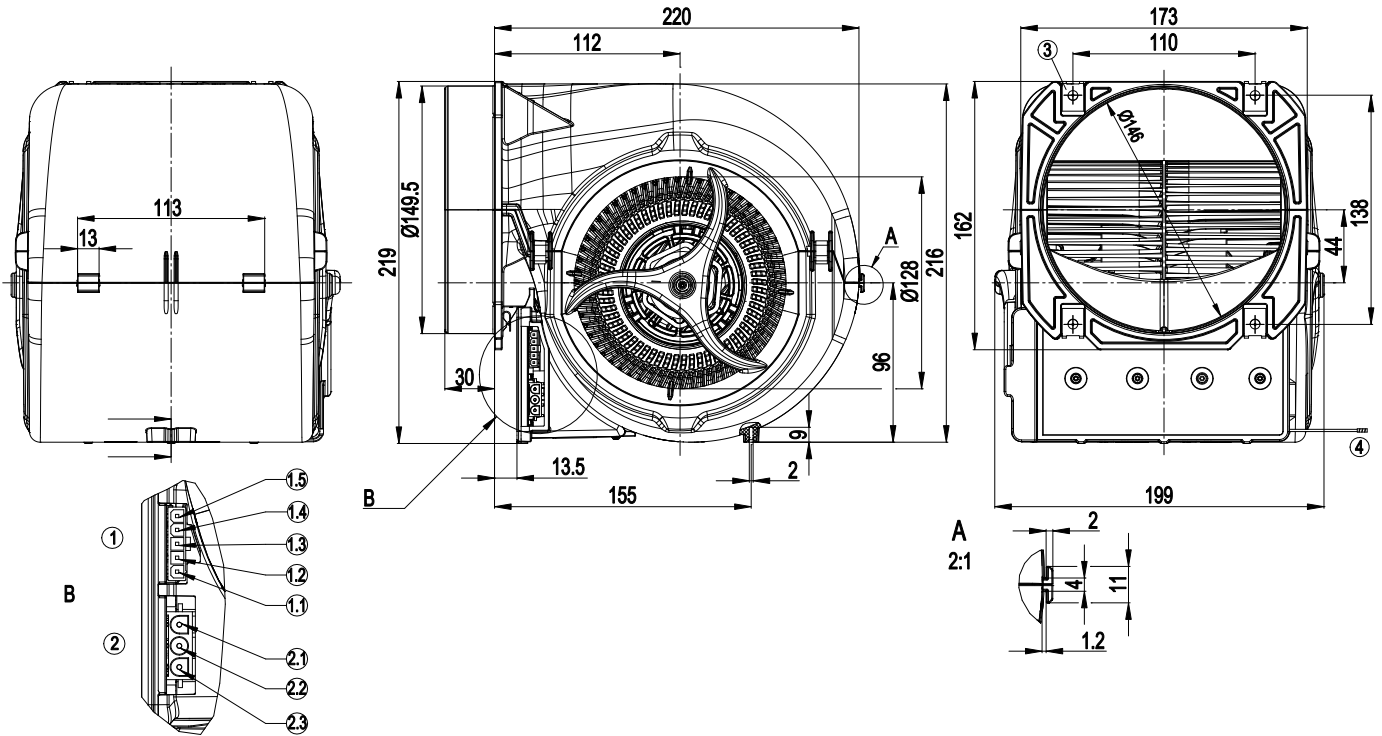

1	Strip Molex Mini-Fit 39-30-3055, pluggable with connector housing Molex 39-01-4050
1.1	10V
1.2	Tach
1.3	0-10V lin. / PWM
1.4	Not assigned
1.5	GND
2	Pin socket AMP Mate-N-Lok 1-350943-0, pluggable with connector housing AMP 350766-4
2.1	PE
2.2	N
2.3	L
3	4 x sheet metal nut for thread EN ISO 1478-ST4.8 (min. screw length 14.5 mm plus thickness of mounting material)
4	EMC earth, 1 x brass lead tip crimped



EC centrifugal fan

forward curved, dual inlet
with housing (large flange)

Connection screen

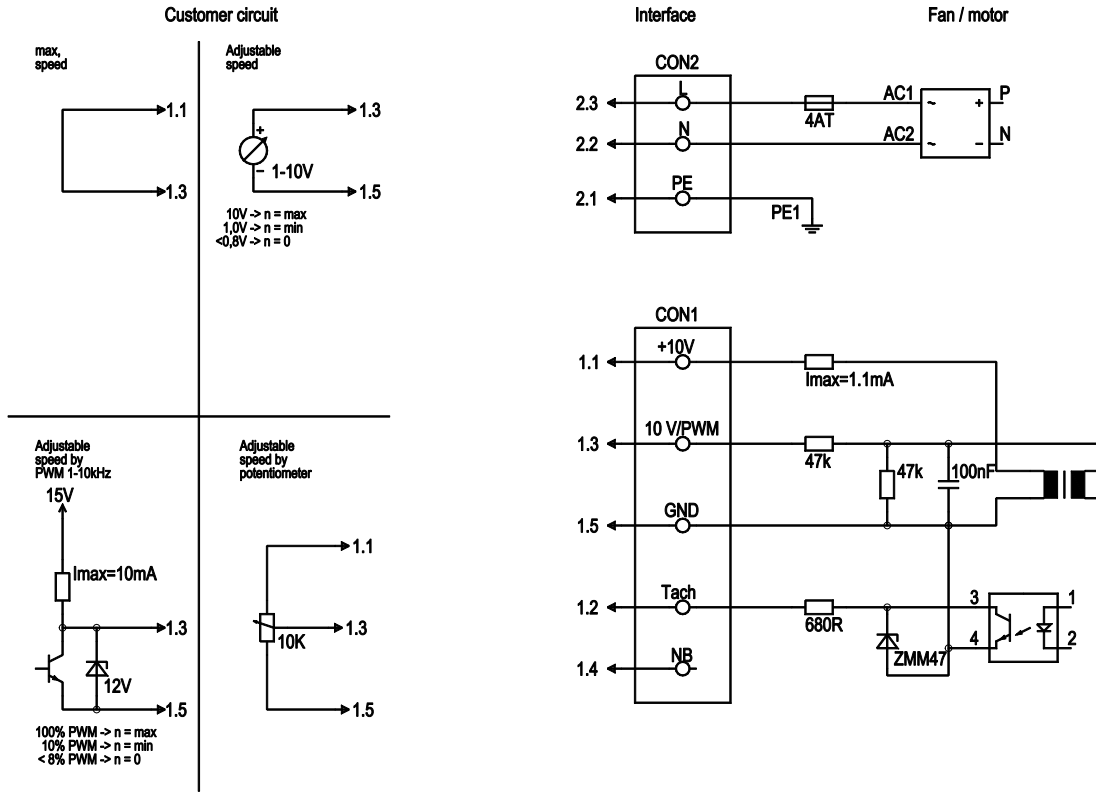

No.	Pin	Signal	Function / assignment
CON1	1.1	10 V/max. 1.1 mA	Voltage output 10 V/ 1.1 mA, electrically isolated
CON1	1.2	Tach	Tach output: open collector, 1 pulse per revolution, electrically isolated
CON1	1.3	0-10 V PWM	Control input 0 - 10 V or PWM, electrically isolated
CON1	1.4	NB	Not assigned
CON1	1.5	GND	GND - Connection for control interface
CON2	2.1	PE	Protective earth
CON2	2.2	N	Neutral conductor
CON2	2.3	L	Power supply 230 VAC, 50-60 Hz, for voltage range refer to rating plate



Charts: Air flow 50 Hz

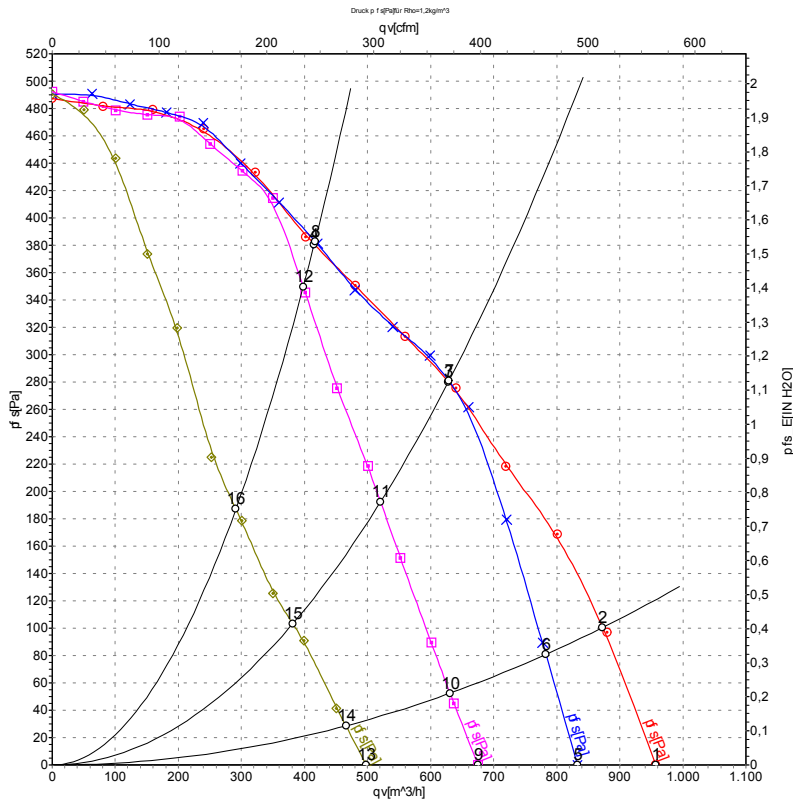

Measurement: LU-132080
Measurement: LU-132083
Measurement: LU-132084
Measurement: LU-132086

Air performance measured as per ISO 5801 Installation category A. For detailed information on the measuring set-up, please contact ebm-papst. Suction-side noise levels: L_{wA} measured as per ISO 13347 / L_{pA} measured with 1m distance to fan axis. The values given are valid under the measuring conditions mentioned above and may vary according to the actual installation situation. With any deviation from the standard set-up, the specific values have to be checked and reviewed with the unit installed.

Measured values

	U	f	n	P _{ed}	I	qv	P _{fs}
	V	Hz	min ⁻¹	W	A	m ³ /h	Pa
1	230	50	1610	165	1.30	955	0
2	230	50	1830	165	1.30	875	100
3	230	50	2165	134	1.06	630	280
4	230	50	2445	110	0.89	415	380
5	230	50	1390	100	0.80	835	0
6	230	50	1640	113	0.91	785	81
7	230	50	2175	136	1.07	630	281
8	230	50	2450	110	0.90	415	383
9	230	50	1130	50	0.43	675	0
10	230	50	1325	59	0.49	630	52
11	230	50	1810	73	0.61	520	192
12	230	50	2345	94	0.76	400	350
13	230	50	865	22	0.21	500	0
14	230	50	1000	25	0.23	465	28
15	230	50	1360	32	0.28	380	103
16	230	50	1740	40	0.35	290	187

U = Supply voltage · f = Frequency · n = Speed · P_{ed} = Power input · I = Current draw · qv = Air flow · p_{fs} = Pressure increase

