

D3G133-BF03-06

EC centrifugal fan

forward curved, dual inlet

with housing (flange)

D3G133-BF03-06 ebmpapst Datasheet

sales@fansco.com

www.fansco.com

Nominal data

Type	D3G133-BF03-06	
Motor	M3G055-CF	
Phase		1~
Nominal voltage	VAC	230
Nominal voltage range	VAC	195 .. 253
Frequency	Hz	50/60
Type of data definition		fa
Speed	min ⁻¹	1260
Power input	W	86
Current draw	A	0.64
Min. ambient temperature	°C	-25
Max. ambient temperature	°C	+40

ml = Max. load · me = Max. efficiency · fa = Running at free air · cs = Customer specs · cu = Customer unit
Subject to alterations



EC centrifugal fan

forward curved, dual inlet
with housing (flange)

Technical features

Mass	3 kg
Size	133 mm
Surface of rotor	Uncoated
Material of impeller	Sheet steel, galvanised
Housing material	Sheet steel, galvanised
Motor suspension	Motor mounted via brackets on one side
Direction of rotation	Clockwise, seen on rotor
Type of protection	IP 42
Insulation class	"B"
Humidity class	F3-1
Max. permissible ambient motor temp. (transp./ storage)	+ 80 °C
Min. permissible ambient motor temp. (transp./storage)	- 40 °C
Mounting position	Shaft horizontal
Condensate discharge holes	None
Operation mode	S1
Motor bearing	Ball bearing
Technical features	<ul style="list-style-type: none"> - Output 10 VDC, max. 1.1 mA - Tach output - Motor current limit - Soft start - Control input 0-10 VDC / PWM - Control interface with SELV potential safely disconnected from the mains - Over-temperature protected motor
EMC interference immunity	Acc. to EN 61000-6-2 (industrial environment)
EMC harmonics	Acc. to EN 61000-3-2/3
EMC interference emission	Acc. to EN 61000-6-3 (household environment)
Touch current acc. IEC 60990 (measuring network Fig. 4, TN system)	<= 3.5 mA
Electrical leads	With plug
Motor protection	Thermal overload protector (TOP) wired internally
Cable exit	Lateral
Protection class	I (if protective earth is connected by customer)
Product conforming to standard	EN 60335-1



EC centrifugal fan

forward curved, dual inlet
with housing (flange)

Product drawing

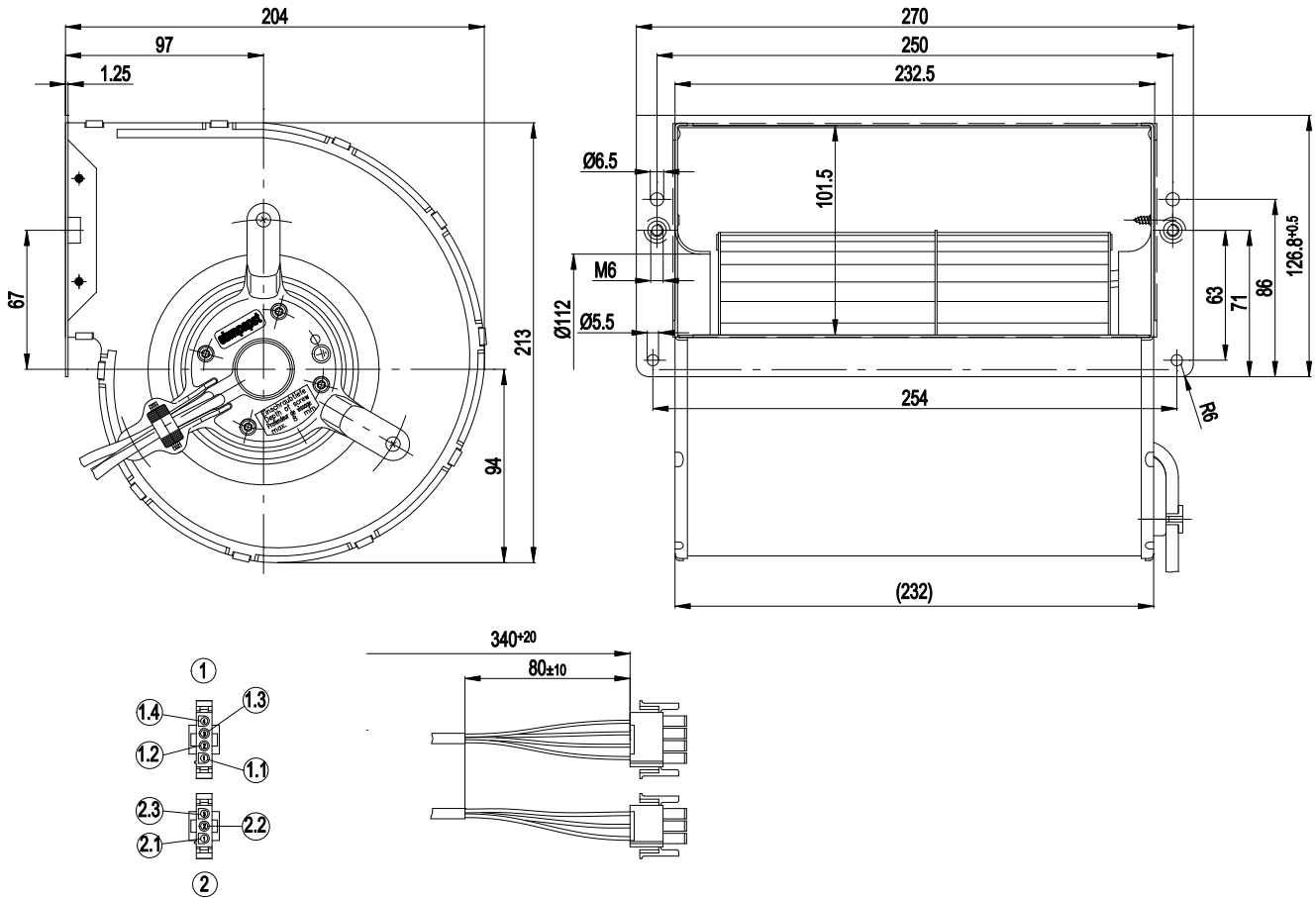

1	Connection line PVC 4 x 0.25 mm ² with plug: AMP Mate-N-Lok 480702-0
1.1	red
1.2	yellow
1.3	Light blue
1.4	white
2	Connection line PVC 3G x 0.5 mm ² with plug: AMP Mate-N-Lok-480702-0
2.1	brown
2.2	blue
2.3	green/yellow



EC centrifugal fan

forward curved, dual inlet
with housing (flange)

Connection screen

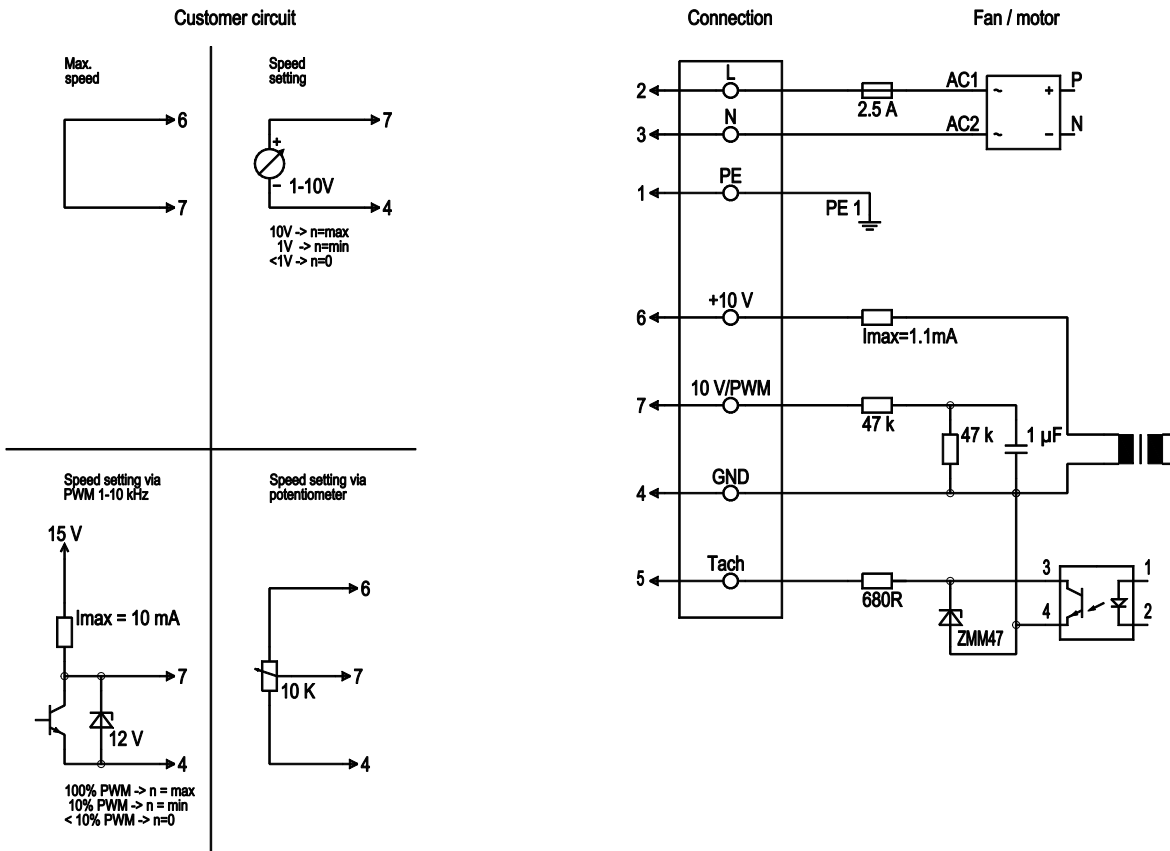

Line	No.	Signal	Colour	Function / assignment
	2	L	brown	Power supply 230 VAC, 50-60 Hz, see type plate for voltage range
	3	N	blue	Neutral conductor
	1	PE	green/yellow	Protective earth
	7	0-10 V PWM	yellow	Control input 0 - 10 V or PWM, electrically isolated
	5	Tach	white	Tach output: Open Collector, 1 pulse per revolution, electrically isolated
	6	10V / max. 1.1 mA	red	Voltage output 10V / 1.1mA, electrically isolated, not short-circuit-proof
	4	GND	blue	GND - Connection for control interface



EC centrifugal fan

forward curved, dual inlet
with housing (flange)

Charts: Air flow 50 Hz

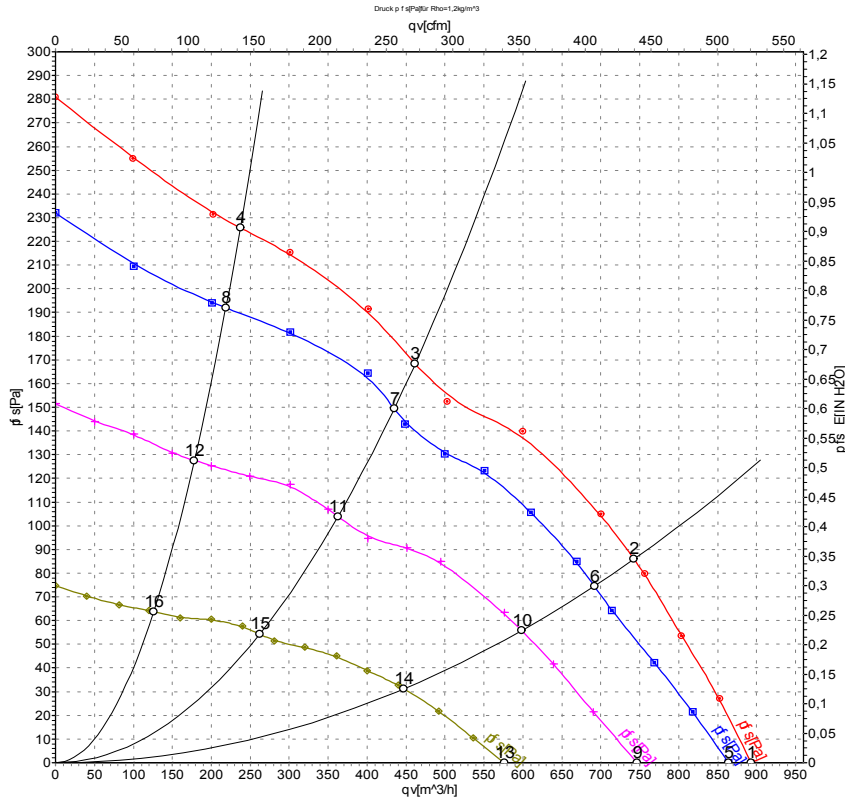

Measurement: LU-108839
Measurement: LU-108841
Measurement: LU-108842
Measurement: LU-108844

Air performance measured as per ISO 5801 Installation category A. For detailed information on the measuring set-up, please contact ebm-papst. Suction-side noise levels: LwA measured as per ISO 13347 / LpA measured with 1m distance to fan axis. The values given are valid under the measuring conditions mentioned above and may vary according to the actual installation situation. With any deviation from the standard set-up, the specific values have to be checked and reviewed with the unit installed.

Measured values

	U	f	n	P _{ed}	I	qv	P _{fs}
	V	Hz	min ⁻¹	W	A	m ³ /h	Pa
1	230	50	1260	86	0.64	890	0
2	230	50	1550	82	0.63	740	85
3	230	50	1825	62	0.48	460	165
4	230	50	2055	47	0.36	235	225
5	230	50	1270	83	0.63	865	0
6	230	50	1460	69	0.54	690	75
7	230	50	1720	51	0.39	435	149
8	230	50	1930	39	0.30	220	192
9	230	50	1110	53	0.41	745	0
10	230	50	1270	44	0.34	600	56
11	230	50	1440	30	0.23	365	104
12	230	50	1570	22	0.17	180	128
13	230	50	855	25	0.19	575	0
14	230	50	960	21	0.16	445	31
15	230	50	1070	15	0.12	260	54
16	230	50	1110	10	0.09	125	64

U = Supply voltage · f = Frequency · n = Speed · P_{ed} = Power input · I = Current draw · qv = Air flow · p_{fs} = Pressure increase

