

D2E160-FK11-10

AC centrifugal fan

forward curved, dual inlet
with housing (large flange)



D2E160-FK11-10 ebmpapst Datasheet
sales@fansco.com
www.fansco.com

Limited partnership · Headquarters Muldingen
County court Stuttgart · HRA 590344

General partner Elektrobau Muldingen GmbH · Headquarters Muldingen
County court Stuttgart · HRB 590142

Nominal data

Type	D2E160-FK11-10	
Motor	M2E068-CF	
Phase		1~
Nominal voltage	VAC	230
Frequency	Hz	50
Type of data definition		ml
Valid for approval / standard		CE
Speed	min ⁻¹	1400
Power input	W	180
Current draw	A	0.8
Motor capacitor	µF	4
Capacitor voltage	VDB	400
Capacitor standard		P2 (CE)
Min. back pressure	Pa	150
Min. ambient temperature	°C	-25
Max. ambient temperature	°C	40
Starting current	A	0.80

ml = max. load · me = max. efficiency · fa = running at free air · cs = customer specs · cu = customer unit
Subject to alterations



AC centrifugal fan

forward curved, dual inlet
with housing (large flange)

Technical features

Mass	2.95 kg
Size	160 mm
Surface of rotor	Uncoated
Material of impeller	Sheet steel, hot-galvanised
Housing material	PP plastic, black
Motor suspension	Motor mounted via brackets on one side
Direction of rotation	Clockwise, seen on rotor
Type of protection	IP 44; Depending on installation and position
Insulation class	"F"
Humidity class	F0
Max. permissible ambient motor temp. (transp./ storage)	+ 80 °C
Min. permissible ambient motor temp. (transp./storage)	- 40 °C
Mounting position	Any
Condensate discharge holes	None
Operation mode	S1
Motor bearing	Ball bearing
Speed steps	4
Touch current acc. IEC 60990 (measuring network Fig. 4, TN system)	< 0.75 mA
Electrical leads	Via terminal box, integrated capacitor connected via terminal box; With plug
Motor protection	Thermal overload protector (TOP) wired internally
Protection class	I (if protective earth is connected by customer)
Product conforming to standard	EN 60335-1; CE
Approval	GOST



AC centrifugal fan

forward curved, dual inlet
with housing (large flange)

Product drawing

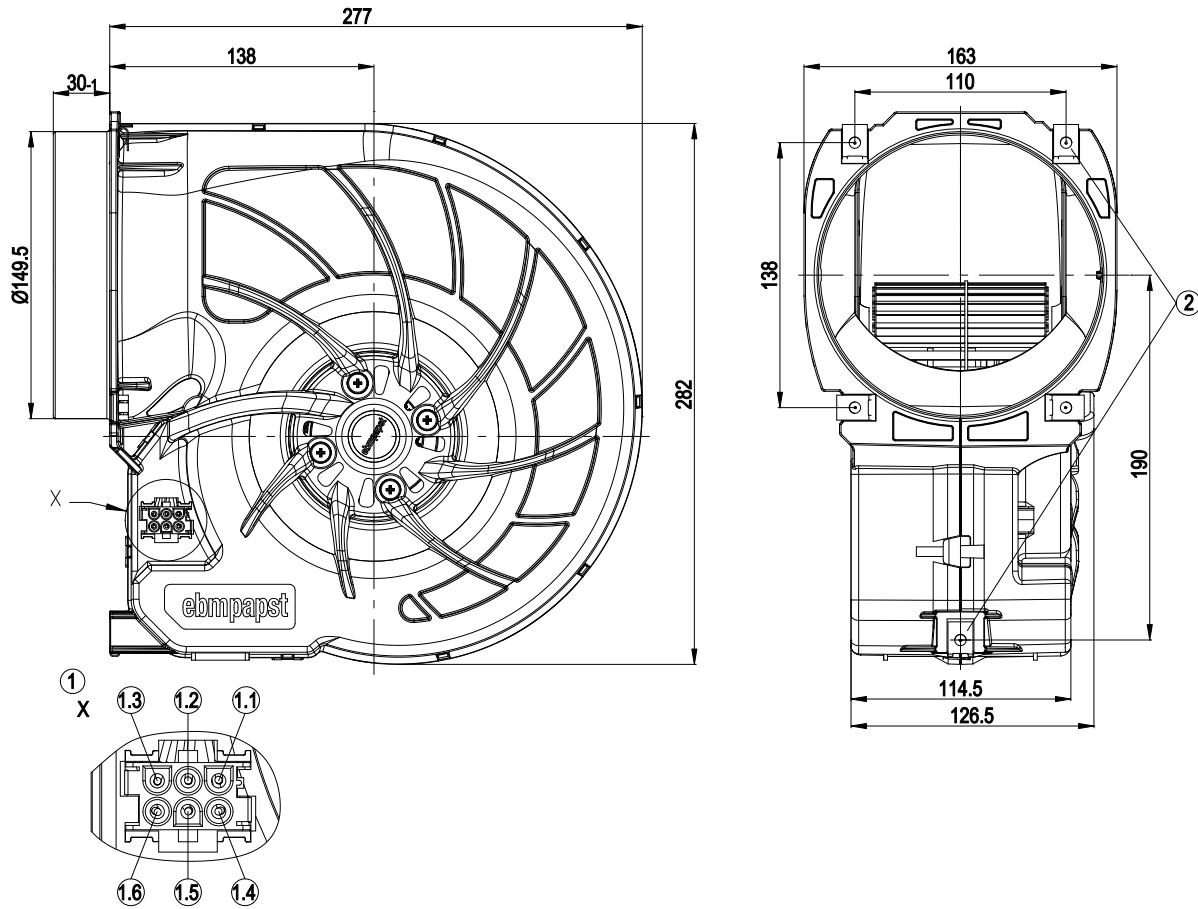

1	Connector housing Universal Mate-N-Lok AMP no. 926 682-3 with 6 x plug pin AMP no. 926 886-1
1.1	Step 1
1.2	Step 2
1.3	Step 3
1.4	Step 4
1.5	N
1.6	PE
2	5 x sheet metal nut for thread EN ISO 1478-ST4.8, min. screw length 14.5mm plus thickness of mounting material



AC centrifugal fan

forward curved, dual inlet
with housing (large flange)

Connection screen

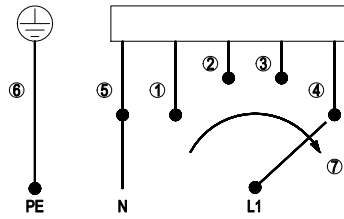

When changing speeds, switch must break the circuit

1	Step 1 (min.)	2	Step 2	3	Step 3
4	Step 4 (max.)	5	N	6	PE protective earth
7	Speed increase				



AC centrifugal fan

forward curved, dual inlet
with housing (large flange)

Charts: Air flow 50 Hz

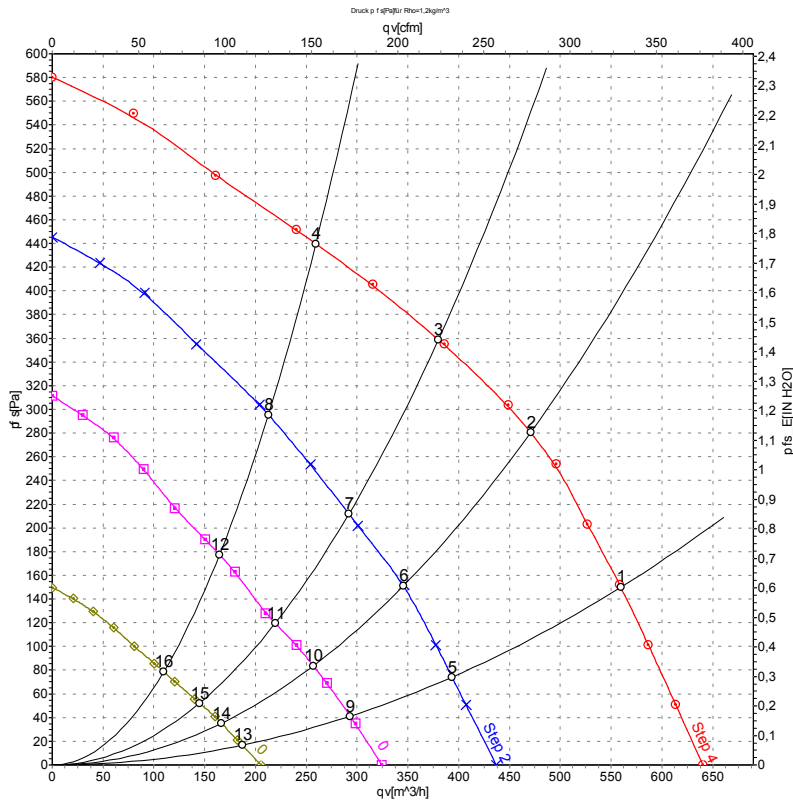

Measurement: LU-72109
Measurement: LU-72112
Measurement: LU-72115
Measurement: LU-72118

Air performance measured as per ISO 5801 Installation category A. For detailed information on the measuring set-up, please contact ebmpapst. Suction-side noise levels: LwA measured as per ISO 13347 / LpA measured with 1m distance to fan axis. The values given are valid under the measuring conditions mentioned above and may vary according to the actual installation situation. With any deviation from the standard set-up, the specific values have to be checked and reviewed with the unit installed.

Measured values

	Stage	U	f	n	P _e	I	qv	P _{fs}
		V	Hz	min ⁻¹	W	A	m ³ /h	Pa
1	4	230	50	1400	180	0.80	560	150
2	4	230	50	1780	166	0.72	470	280
3	4	230	50	2035	158	0.68	380	360
4	4	230	50	2260	146	0.63	260	440
5	3	230	50	1010	120	0.56	395	74
6	3	230	50	1315	116	0.54	345	153
7	3	230	50	1575	111	0.53	290	212
8	3	230	50	1855	104	0.50	215	296
9	2	230	50	770	96	0.46	295	42
10	2	230	50	1005	94	0.46	255	84
11	2	230	50	1210	91	0.45	220	119
12	2	230	50	1450	88	0.44	165	177
13	1	230	50	495	76	0.38	185	17
14	1	230	50	665	75	0.38	165	35
15	1	230	50	805	74	0.37	145	52
16	1	230	50	985	73	0.37	110	79

U = Supply voltage · f = Frequency · n = Speed · P_e = Power input · I = Current draw · qv = Air flow · p_{fs} = Pressure increase

