

AC centrifugal fan

forward-curved, dual-intake
with housing (without flange)

D2E160-AH02-15 ebmpapst Datasheet

sales@fansco.com

www.fansco.com

Nominal data

Type	D2E160-AH02-15		
Motor	M2E074-LA		
Phase		1~	1~
Nominal voltage	VAC	230	230
Frequency	Hz	50	60
Method of obtaining data		ml	ml
Valid for approval/standard		-	-
Speed (rpm)	min ⁻¹	2500	2400
Power consumption	W	550	730
Current draw	A	2.45	3.2
Capacitor	µF	12	12
Capacitor voltage	VDB	400	400
Min. back pressure	Pa	400	390
Min. back pressure	in. wg	1.61	1.57
Min. ambient temperature	°C	-25	-25
Max. ambient temperature	°C	90	50

ml = Max. load · me = Max. efficiency · fa = Free air · cs = Customer specification · ce = Customer equipment
Subject to change



AC centrifugal fan

forward-curved, dual-intake
with housing (without flange)

Technical description

Weight	9.7 kg
Size	160 mm
Motor size	74
Rotor surface	Painted black
Impeller material	Sheet steel, galvanized
Housing material	Sheet steel, galvanized
Guard grille material	Steel, phosphated and coated with white-aluminum plastic (RAL 9006)
Motor suspension	Motor vibration-damped on both sides
Direction of rotation	Counterclockwise, viewed toward rotor
Degree of protection	IP00
Insulation class	"F"
Moisture (F) / Environmental (H) protection class	F2-1
Max. permitted ambient temp. for motor (transport/storage)	+ 80 °C
Min. permitted ambient temp. for motor (transport/storage)	- 40 °C
Installation position	Shaft horizontal
Condensation drainage holes	None, open rotor
Mode	S1
Motor mounting	Ball bearing
Touch current according to IEC 60990 (measuring circuit Fig. 4, TN system)	< 0.75 mA
Electrical hookup	Via terminal strip, capacitor connected
Motor protection	Thermal overload protector (TOP) with basic insulation
With cable	Axial
Pollution degree	2
Protection class	I (with customer connection of protective earth)
Motor capacitor according to EN 60252-1 in safety protection class	S0
Conformity with standards	EN 60335-1
Approval	CCC
Comment	Thermal overload protector with basic insulation



AC centrifugal fan

forward-curved, dual-intake
with housing (without flange)

Product drawing

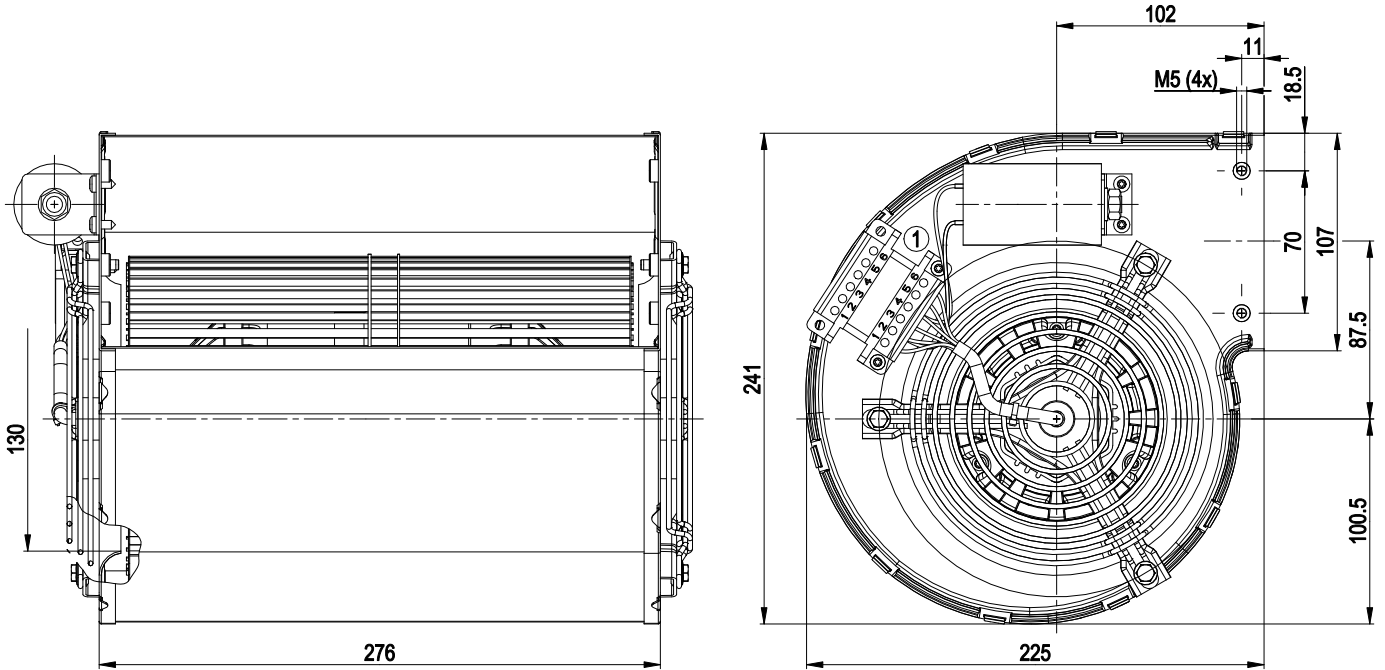

No.	Conn.	Designation	Function/assignment
1			Header Weidmüller 1612070000 & header connector Weidmüller 1612080000
			Terminal assignment:
	1	PE	green/yellow
	2		brown + capacitor
	3	L	blue
	4	N	black + capacitor
	5	TOP	gray
	6	TOP	gray



AC centrifugal fan

forward-curved, dual-intake
with housing (without flange)

Connection diagram

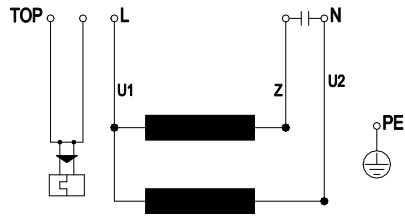

TOP	2x gray	U1	blue	Z	brown
U2	black	PE	green/yellow		

AC centrifugal fan

forward-curved, dual-intake
with housing (without flange)

Curves: Air performance 50 Hz

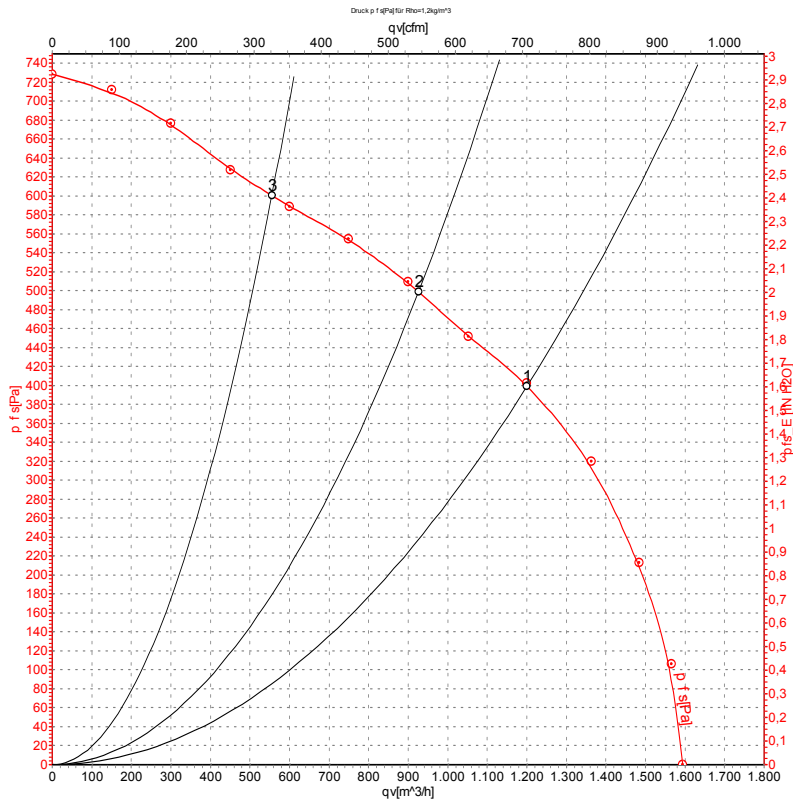

Measurement: LU-109474-1

Air performance measured according to ISO 5801 installation category A. For detailed information on the measurement setup, contact ebm-papst. Intake sound level: Sound power level according to ISO 13347 / sound pressure level measured at 1 m distance from fan axis. The values given are valid under the specified measuring conditions and may vary due to conditions of installation. For deviations from the standard configuration, the parameters have to be checked on the installed unit.

Measured values

	U	f	n	P _e	I	q _v	P _{is}	q _v	P _{is}
	V	Hz	min ⁻¹	W	A	m ³ /h	Pa	cfm	in. wg
1	230	50	2500	550	2.45	1200	400	705	1.61
2	230	50	2630	515	2.35	925	500	545	2.01
3	230	50	2715	456	2.18	555	600	325	2.41

U = Power supply · f = Frequency · n = Speed (rpm) · P_e = Power consumption · I = Current draw · q_v = Air flow · P_{is} = Pressure increase



AC centrifugal fan

forward-curved, dual-intake
with housing (without flange)

Curves: Air performance 60 Hz

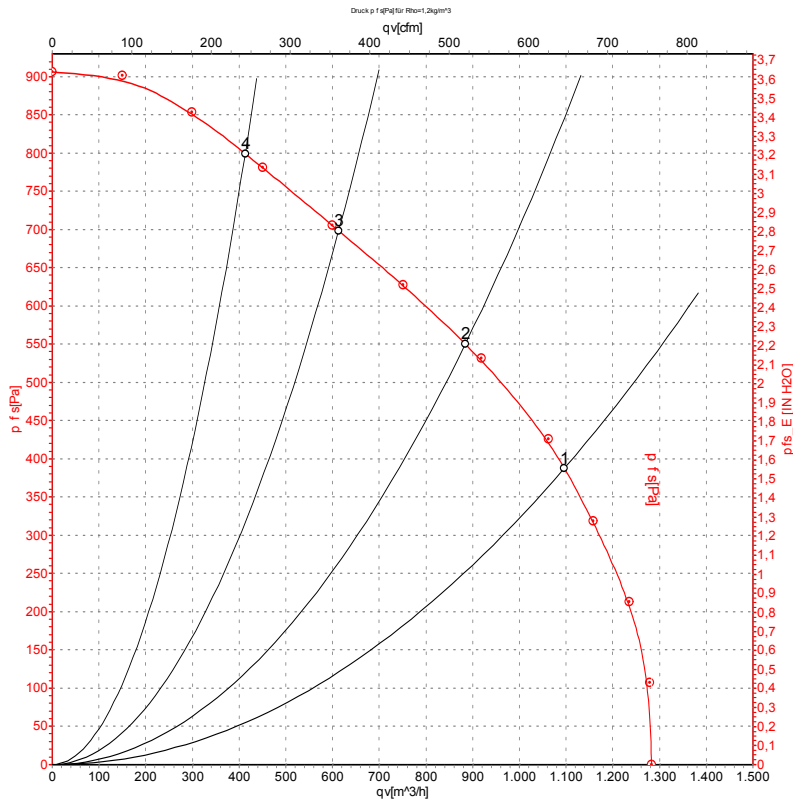

Measurement: LU-109478-1

Air performance measured according to ISO 5801 installation category A. For detailed information on the measurement setup, contact ebmpapst. Intake sound level: Sound power level according to ISO 13347 / sound pressure level measured at 1 m distance from fan axis. The values given are valid under the specified measuring conditions and may vary due to conditions of installation. For deviations from the standard configuration, the parameters have to be checked on the installed unit.

Measured values

	U	f	n	P _e	I	q _v	P _{is}	q _v	P _{is}
	V	Hz	min ⁻¹	W	A	m ³ /h	Pa	cfm	in. wg
1	230	60	2400	730	3.20	1095	390	645	1.57
2	230	60	2715	698	3.05	885	550	520	2.21
3	230	60	2940	663	2.94	615	700	360	2.81
4	230	60	3050	640	2.88	415	800	245	3.21

U = Power supply · f = Frequency · n = Speed (rpm) · P_e = Power consumption · I = Current draw · q_v = Air flow · P_{is} = Pressure increase

