

D2E146-HT59-02 ebmpapst Datasheet

sales@fansco.com

www.fansco.com

Nominal data

Type	D2E146-HT59-02		
Motor	M2E068-EC		
Phase		1~	1~
Nominal voltage	VAC	230	230
Frequency	Hz	50	60
Method of obtaining data		fa	fa
Valid for approval/standard		CE	CE
Speed (rpm)	min ⁻¹	1600	1500
Power consumption	W	290	320
Current draw	A	1.28	1.4
Capacitor	μF	6	6
Capacitor voltage	VDB	400	400
Capacitor standard		S2 (CE)	S2 (CE)
Min. back pressure	Pa	0	0
Min. back pressure	inH ₂ O	0	0
Min. ambient temperature	°C	-25	-25
Max. ambient temperature	°C	50	40
Starting current	A	1.48	1.5

ml = Max. load · me = Max. efficiency · fa = Free air · cs = Customer specification · ce = Customer equipment
Subject to change

Data according to ErP Directive

		Actual	Req. 2015			
01 Overall efficiency η_{es}	%	33.3	33.3	09 Power consumption P_e	kW	0.2
02 Measurement category		A		09 Air flow q_v	m ³ /h	630
03 Efficiency category		Static		09 Pressure increase p_{fs}	Pa	379
04 Efficiency grade N		44	44	10 Speed (rpm) n	min ⁻¹	2410
05 Variable speed drive		No		11 Specific ratio*		1.00

Data obtained at optimum efficiency level.

The ErP data is determined using a motor-impeller combination in a standardized measurement setup.

* Specific ratio = $1 + p_g / 100\,000\text{ Pa}$

LU-156752



AC centrifugal fan

forward-curved, dual-intake

with housing (flange)

Technical description

Weight	3.4 kg
Fan size	146 mm
Rotor surface	Partly cast in aluminum
Terminal box material	PP plastic
Impeller material	Sheet steel, galvanized
Housing material	PP plastic
Motor suspension	Motor vibration-damped on both sides
Direction of rotation	Counterclockwise, viewed toward rotor
Degree of protection	IP20
Insulation class	"F"
Moisture (F) / Environmental (H) protection class	H0 - dry environment
Max. permitted ambient temp. for motor (transport/storage)	+ 80 °C
Min. permitted ambient temp. for motor (transport/storage)	- 40 °C
Installation position	Any
Condensation drainage holes	None, open rotor
Mode	S1
Motor bearing	Ball bearing
Speed levels	4
Touch current according to IEC 60990 (measuring circuit Fig. 4, TN system)	< 0.75 mA
Electrical hookup	With plug; Via terminal box, capacitor integrated and connected
Motor protection	Thermal overload protector (TOP) internally connected
With cable	Variable
Protection class	I (with customer connection of protective earth)
Motor capacitor according to EN 60252-1 in safety protection class	S2
Conformity with standards	EN 60335-1; EN 60335-2-31; CE
Approval	VDE



AC centrifugal fan

forward-curved, dual-intake
with housing (flange)

Product drawing

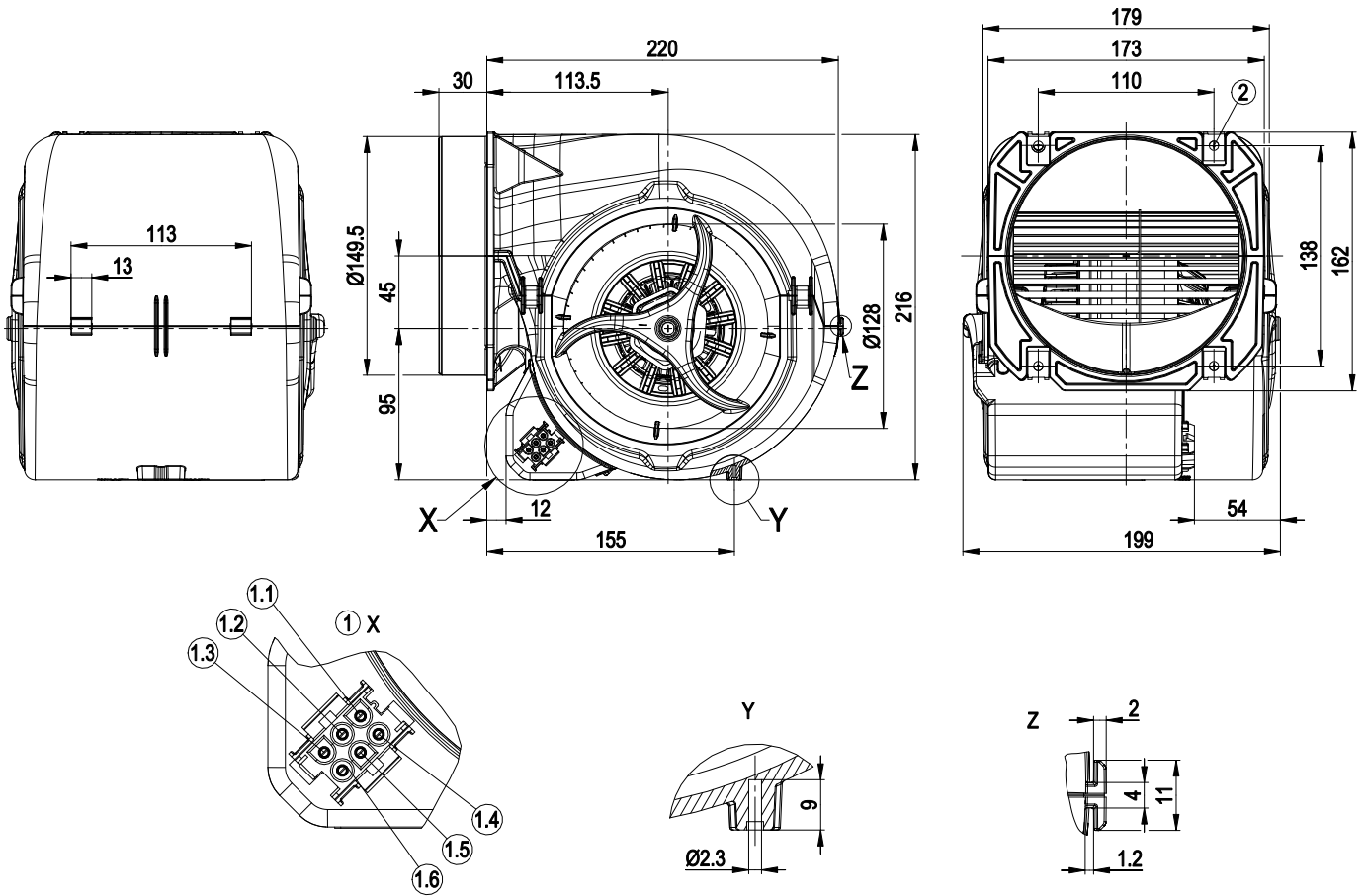

1	Coded plug system AMP Universal Mate-N-Lok; connector housing: AMP 926 682-3; 6x plug pin AMP 926 886-1
1.1	L = step 1
1.2	L = step 2
1.3	L = step 3
1.4	L = step 4
1.5	N
1.6	Protective earth
2	4x sheet metal nut for thread EN ISO 1478-ST4.8 (min. screw length 14.5 mm plus material thickness of mounting)



AC centrifugal fan

forward-curved, dual-intake
with housing (flange)

Connection diagram

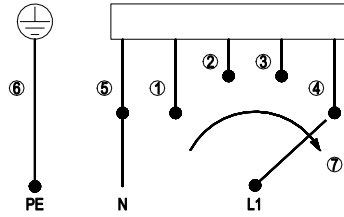

The switch must interrupt the circuit when switching.

1	Step 1 (min.)	2	Step 2	3	Step 3
4	Step 4 (max.)	5	N	6	PE protective earth
7	Speed increasing				



Curves: Air performance 50 Hz

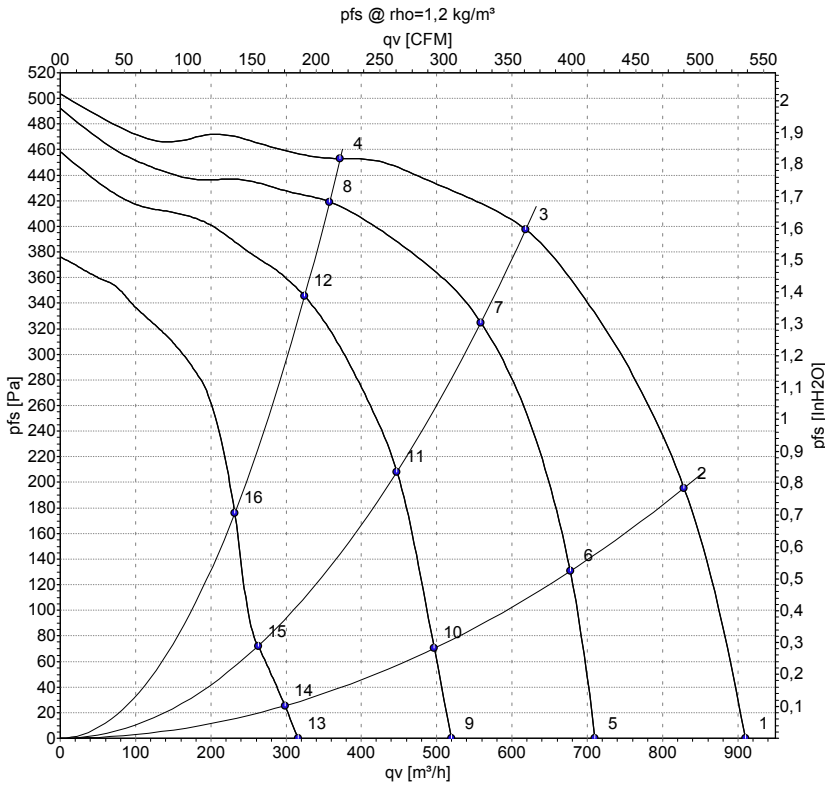

Measurement: LU-156752-1
 Measurement: LU-156754-1
 Measurement: LU-156757-1
 Measurement: LU-156762-1

Air performance measured according to ISO 5801 installation category A. For detailed information on the measurement setup, contact ebmpapst. Intake sound level: Sound power level according to ISO 13347 / sound pressure level measured at 1 m distance from fan axis. The values given are valid under the specified measuring conditions and may vary due to conditions of installation. For deviations from the standard configuration, the parameters have to be checked on the installed unit.

Measured values

	U	f	n	P _e	I	LpA _{in}	LwA _{in}	q _v	P _{fs}	q _v	P _{fs}
	V	Hz	min ⁻¹	W	A	dB(A)	dB(A)	m ³ /h	Pa	cfm	inH2O
1	230	50	1600	290	1.28	62	73	910	0	535	0.00
2	230	50	2020	256	1.12	61	73	830	200	490	0.80
3	230	50	2420	203	0.89	60	72	620	400	365	1.61
4	230	50	2645	161	0.70	63	74	370	450	220	1.81
5	230	50	1280	247	1.08	56	67	710	0	420	0.00
6	230	50	1665	226	0.99	56	68	675	133	400	0.53
7	230	50	2210	183	0.83	59	70	560	325	330	1.30
8	230	50	2550	140	0.66	63	74	360	421	210	1.69
9	230	50	960	203	0.89	48	59	520	0	305	0.00
10	230	50	1235	196	0.87	49	60	495	70	295	0.28
11	230	50	1805	174	0.78	53	65	445	214	265	0.86
12	230	50	2330	133	0.63	60	71	325	345	190	1.39
13	230	50	595	163	0.72	36	47	315	0	185	0.00
14	230	50	765	160	0.71	36	47	300	26	175	0.10
15	230	50	1065	154	0.68	40	52	265	72	155	0.29
16	230	50	1675	138	0.63	51	62	230	181	135	0.73

U = Power supply · f = Frequency · n = Speed (rpm) · P_e = Power consumption · I = Current draw · LpA_{in} = Sound pressure level intake side · LwA_{in} = Sound power level intake side
 q_v = Air flow · p_{fs} = Pressure increase



AC centrifugal fan

forward-curved, dual-intake

with housing (flange)

Curves: Air performance 60 Hz

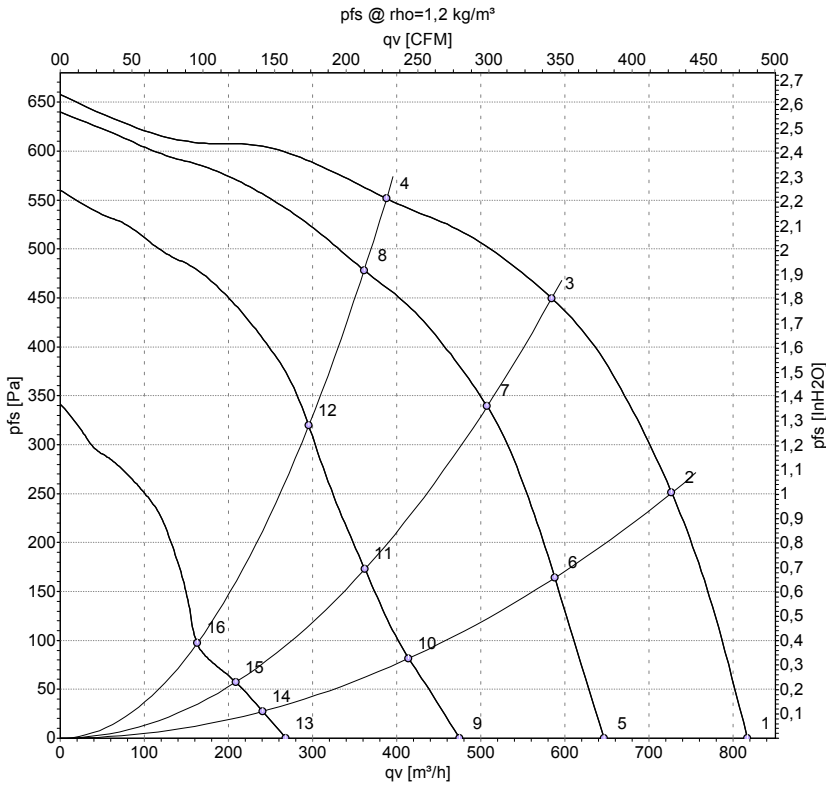

Measurement: LU-156771-1
 Measurement: LU-156772-1
 Measurement: LU-156773-1
 Measurement: LU-156774-1

Air performance measured according to ISO 5801 installation category A. For detailed information on the measurement setup, contact ebmpapst. Intake sound level: Sound power level according to ISO 13347 / sound pressure level measured at 1 m distance from fan axis. The values given are valid under the specified measuring conditions and may vary due to conditions of installation. For deviations from the standard configuration, the parameters have to be checked on the installed unit.

Measured values

	U	f	n	P _e	I	LpA _{in}	LwA _{in}	q _v	P _{fs}	q _v	P _{fs}
	V	Hz	min ⁻¹	W	A	dB(A)	dB(A)	m ³ /h	Pa	cfm	inH2O
1	230	60	1500	320	1.40	60	71	815	0	480	0.00
2	230	60	2085	296	1.28	60	71	725	250	430	1.00
3	230	60	2570	267	1.17	62	73	585	450	345	1.81
4	230	60	2930	236	1.06	65	77	390	550	230	2.21
5	230	60	1170	254	1.11	54	65	645	0	380	0.00
6	230	60	1685	244	1.08	54	66	590	164	345	0.66
7	230	60	2260	221	1.01	59	70	505	339	300	1.36
8	230	60	2720	188	0.92	64	75	360	477	210	1.91
9	230	60	875	204	0.92	46	57	475	0	280	0.00
10	230	60	1225	197	0.89	46	56	415	81	245	0.33
11	230	60	1640	192	0.88	51	62	360	173	215	0.69
12	230	60	2255	169	0.82	59	70	295	320	175	1.28
13	230	60	515	157	0.72	29	40	270	0	160	0.00
14	230	60	730	153	0.70	30	41	240	28	140	0.11
15	230	60	955	151	0.69	36	47	210	57	120	0.23
16	230	60	1245	147	0.68	42	53	165	93	95	0.37

U = Power supply · f = Frequency · n = Speed (rpm) · P_e = Power consumption · I = Current draw · LpA_{in} = Sound pressure level intake side · LwA_{in} = Sound power level intake side
 q_v = Air flow · p_{fs} = Pressure increase

