

D2E146-HS97-04

AC centrifugal fan

forward-curved, dual-intake

with housing (flange)



D2E146-HS97-04 ebmpapst Datasheet FansCo

sales@fansco.com

www.fansco.com

Nominal data

Type	D2E146-HS97-04		
Motor	M2E068-DF		
Phase		1~	1~
Nominal voltage	VAC	230	230
Frequency	Hz	50	60
Method of obtaining data		fa	ml
Valid for approval/standard		CE	CE
Speed (rpm)	min ⁻¹	1350	1750
Power consumption	W	195	215
Current draw	A	0.86	0.94
Capacitor	µF	5	5
Capacitor voltage	VDB	400	400
Capacitor standard		S2 (CE)	S2 (CE)
Min. back pressure	Pa	0	150
Min. back pressure	in. wg	0	0.6
Min. ambient temperature	°C	-20	-20
Max. ambient temperature	°C	45	40

ml = Max. load · me = Max. efficiency · fa = Free air · cs = Customer specification · ce = Customer equipment
Subject to change



AC centrifugal fan

forward-curved, dual-intake
with housing (flange)

Technical description

Weight	3.4 kg
Size	146 mm
Motor size	68
Impeller material	Sheet steel, hot-dip galvanized
Housing material	PP plastic, black
Guard grille material	Plastic, A3X black
Direction of rotation	Counterclockwise, viewed toward rotor
Degree of protection	IP20
Insulation class	"F"
Moisture (F) / Environmental (H) protection class	H0 - dry environment
Max. permitted ambient temp. for motor (transport/storage)	+ 80 °C
Min. permitted ambient temp. for motor (transport/storage)	- 40 °C
Installation position	Any
Condensation drainage holes	None
Mode	S1
Motor mounting	Calotte bearing
Speed levels	4
Touch current according to IEC 60990 (measuring circuit Fig. 4, TN system)	< 0.75 mA
Electrical hookup	Plug; Via terminal box, capacitor integrated and connected
Motor protection	Thermal overload protector (TOP) internally connected
With cable	Variable
Motor capacitor according to EN 60252-1 in safety protection class	S2
Conformity with standards	EN 60335-2-31; CE
Approval	VDE



AC centrifugal fan

forward-curved, dual-intake
with housing (flange)

Product drawing

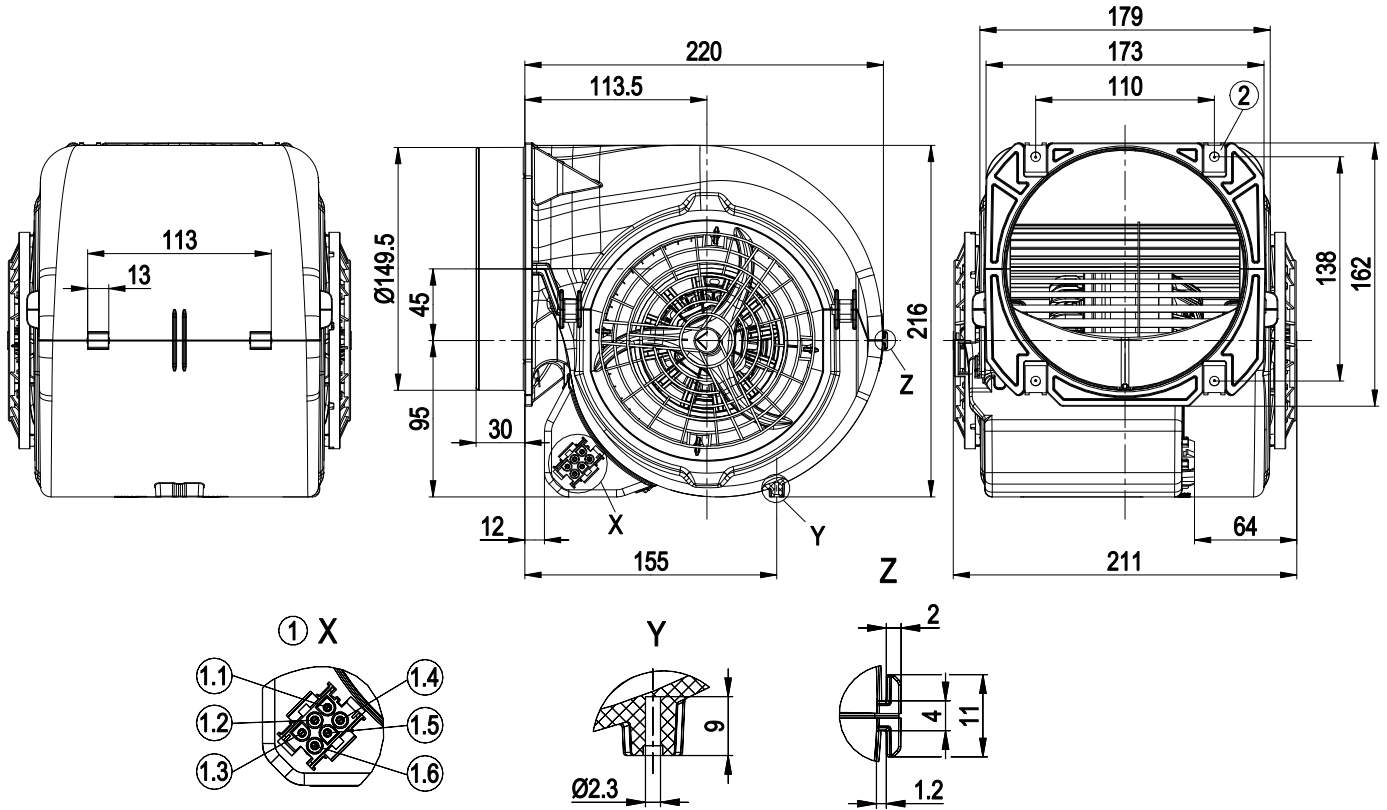

1	Coded plug system: 6-pole connector housing TE 2178773-1, 6x plug pin TE 926886-1
1.1	L = step 1
1.2	L = step 2
1.3	L = step 3
1.4	L = step 4
1.5	N
1.6	Protective earth
2	4x sheet metal nut for thread EN ISO 1478-ST4.8 (min. screw length 14.5 mm plus material thickness of mounting)



AC centrifugal fan

forward-curved, dual-intake

with housing (flange)

Connection diagram

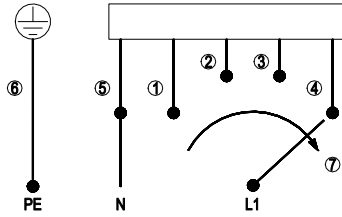

The switch must interrupt the circuit when switching.

1	Step 1 (min.)	2	Step 2	3	Step 3
4	Step 4 (max.)	5	N	6	PE protective earth
7	Speed increasing				



AC centrifugal fan

forward-curved, dual-intake

with housing (flange)

Curves: Air performance 50 Hz

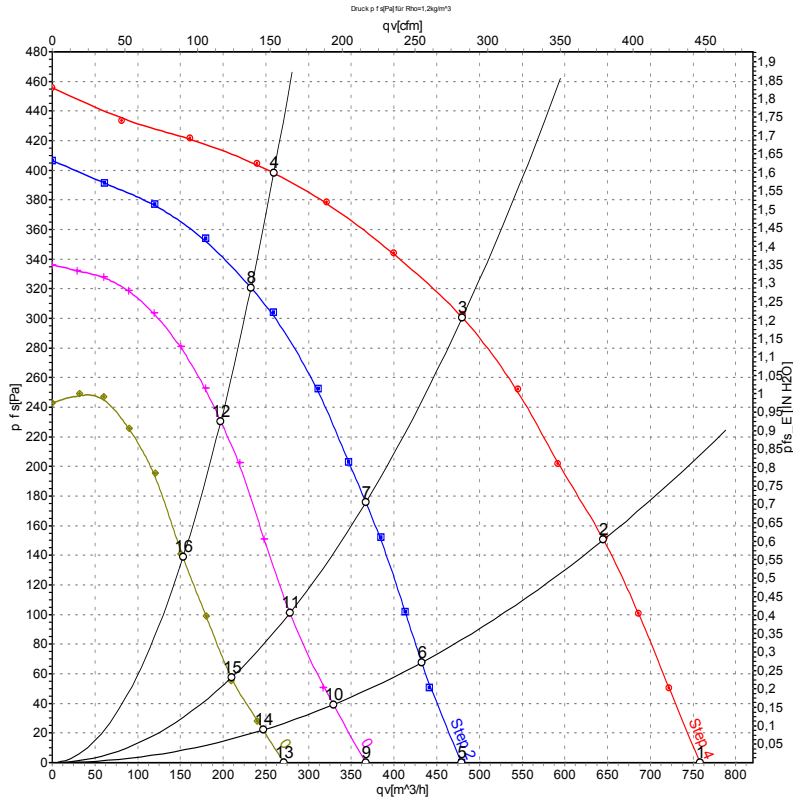

Measurement: LU-72087-1
 Measurement: LU-72089-1
 Measurement: LU-72091-1
 Measurement: LU-72094-1

Air performance measured according to ISO 5801 installation category A. For detailed information on the measurement setup, contact ebmpapst. Intake sound level: Sound power level according to ISO 13347 / sound pressure level measured at 1 m distance from fan axis. The values given are valid under the specified measuring conditions and may vary due to conditions of installation. For deviations from the standard configuration, the parameters have to be checked on the installed unit.

Measured values

	Stage	U	f	n	Pe	I	LpA _{in}	LwA _{in}	qv	Ps	qv	Ps
		V	Hz	min ⁻¹	W	A	dB(A)	dB(A)	m ³ /h	Pa	cfm	in. wg
1	4	230	50	1350	195	0.86	53	65	760	0	445	0.00
2	4	230	50	1795	185	0.81	53	65	645	150	380	0.60
3	4	230	50	2200	169	0.75	55	67	480	300	285	1.20
4	4	230	50	2520	146	0.65	58	70	260	400	150	1.61
5	3	230	50	875	128	0.61	42	54	480	0	280	0.00
6	3	230	50	1215	125	0.60	43	55	430	67	255	0.27
7	3	230	50	1680	116	0.58	49	61	365	176	215	0.71
8	3	230	50	2255	94	0.52	56	68	235	321	135	1.29
9	2	230	50	660	109	0.53	35	46	365	0	215	0.00
10	2	230	50	915	106	0.52	36	48	330	38	195	0.15
11	2	230	50	1280	102	0.51	43	54	280	100	165	0.40
12	2	230	50	1920	88	0.48	52	64	195	230	115	0.92
13	1	230	50	510	95	0.47	27	39	270	0	160	0.00
14	1	230	50	715	94	0.47	28	40	245	22	145	0.09
15	1	230	50	960	92	0.46	34	46	210	55	125	0.22
16	1	230	50	1515	85	0.44	46	58	155	138	90	0.55

U = Power supply · f = Frequency · n = Speed (rpm) · Pe = Power consumption · I = Current draw · LpA_{in} = Sound pressure level intake side · LwA_{in} = Sound power level intake side
 qv = Air flow · Ps = Pressure increase



Curves: Air performance 60 Hz

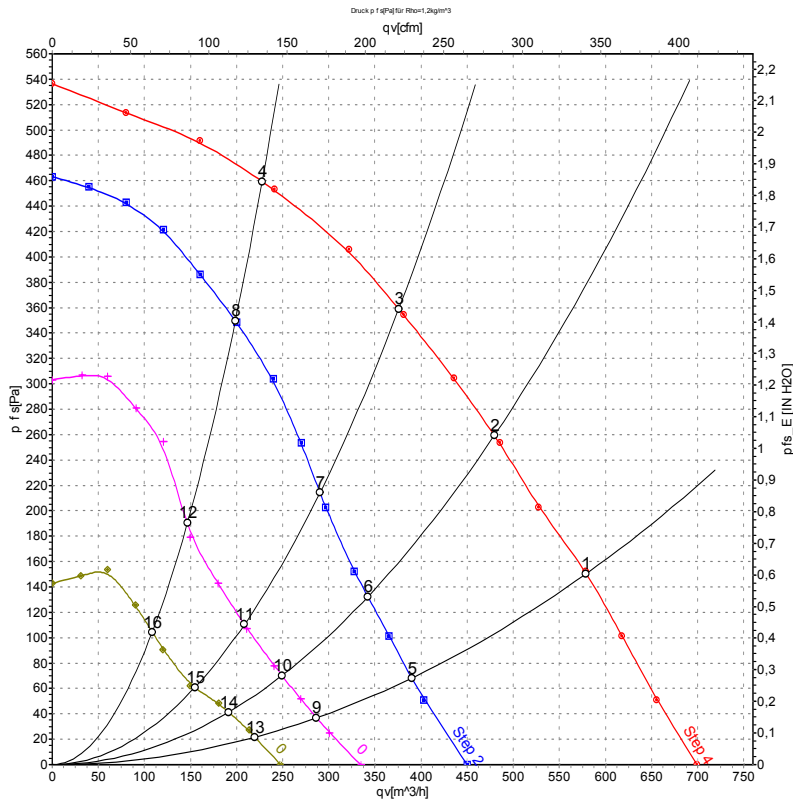

Measurement: LU-72088-1
 Measurement: LU-72090-1
 Measurement: LU-72092-1
 Measurement: LU-72095-1

Air performance measured according to ISO 5801 installation category A. For detailed information on the measurement setup, contact ebmpapst. Intake sound level: Sound power level according to ISO 13347 / sound pressure level measured at 1 m distance from fan axis. The values given are valid under the specified measuring conditions and may vary due to conditions of installation. For deviations from the standard configuration, the parameters have to be checked on the installed unit.

Measured values

	Stage	U	f	n	Pe	I	qv	Pfs	qv	Pfs
		V	Hz	min ⁻¹	W	A	m ³ /h	Pa	cfm	in. wg
1	4	230	60	1750	215	0.94	580	150	340	0.60
2	4	230	60	2060	212	0.93	480	260	280	1.04
3	4	230	60	2380	208	0.91	375	360	220	1.45
4	4	230	60	2710	201	0.89	230	460	135	1.85
5	3	230	60	1175	131	0.67	390	68	230	0.27
6	3	230	60	1485	129	0.67	340	132	200	0.53
7	3	230	60	1855	125	0.66	290	214	170	0.86
8	3	230	60	2365	114	0.65	200	350	115	1.41
9	2	230	60	890	106	0.57	285	37	170	0.15
10	2	230	60	1100	105	0.57	250	70	145	0.28
11	2	230	60	1365	104	0.57	210	110	120	0.44
12	2	230	60	1835	99	0.56	145	187	85	0.75
13	1	230	60	665	92	0.50	220	22	130	0.09
14	1	230	60	820	91	0.50	190	41	115	0.16
15	1	230	60	1010	90	0.50	155	60	90	0.24
16	1	230	60	1325	88	0.50	110	104	65	0.42

U = Power supply · f = Frequency · n = Speed (rpm) · Pe = Power consumption · I = Current draw · qv = Air flow · Pfs = Pressure increase

