

AC centrifugal fan

forward curved, dual inlet

with housing (flange)

D2E146-HS21-80 ebmpapst Datasheet

sales@fansco.com

www.fansco.com

Limited partnership · Headquarters Muldingen
County court Stuttgart · HRA 590344General partner Elektrobau Muldingen GmbH · Headquarters Muldingen
County court Stuttgart · HRB 590142

Nominal data

Type	D2E146-HS21-80	
Motor	M2E068-DF	
Phase		1~
Nominal voltage range	VAC	220 .. 240
Frequency	Hz	50
Type of data definition		cs/cu
Valid for approval / standard		CE
Speed (rpm)	min ⁻¹	1850
Power input	W	260
Current draw	A	1.14
Motor capacitor	µF	6
Capacitor voltage	VDB	450
Capacitor standard		P2 (CE)
Min. ambient temperature	°C	-20
Max. ambient temperature	°C	-

ml = Max. load · me = Max. efficiency · fa = Running at free air · cs = Customer specs · cu = Customer unit
Subject to alterations



D2E146-HS21-80

AC centrifugal fan

forward curved, dual inlet
with housing (flange)

Technical features

Mass	2.9 kg
Size	146 mm
Surface of rotor	Uncoated
Material of terminal box	PP plastic, black
Material of impeller	PP plastic, white
Housing material	PP plastic, black
Motor suspension	Motor anti-vibration mounted on both sides
Direction of rotation	Counter-clockwise, seen on rotor
Type of protection	IP 20
Insulation class	"F"
Humidity (F)/environmental protection class (H)	H0 - dry environment
Max. permissible ambient motor temp. (transp./ storage)	+ 80 °C
Min. permissible ambient motor temp. (transp./storage)	- 40 °C
Mounting position	Any
Condensate discharge holes	None, open rotor
Operation mode	S1
Motor bearing	Calotte bearing
Speed steps	4
Touch current acc. IEC 60990 (measuring network Fig. 4, TN system)	< 0.75 mA
Electrical leads	With plug; Via terminal box, integrated capacitor connected via terminal box
Motor protection	Thermal overload protector (TOP) wired internally
Product conforming to standard	EN 60335-1; CE
Approval	VDE



D2E146-HS21-80

AC centrifugal fan

forward curved, dual inlet
with housing (flange)

Product drawing

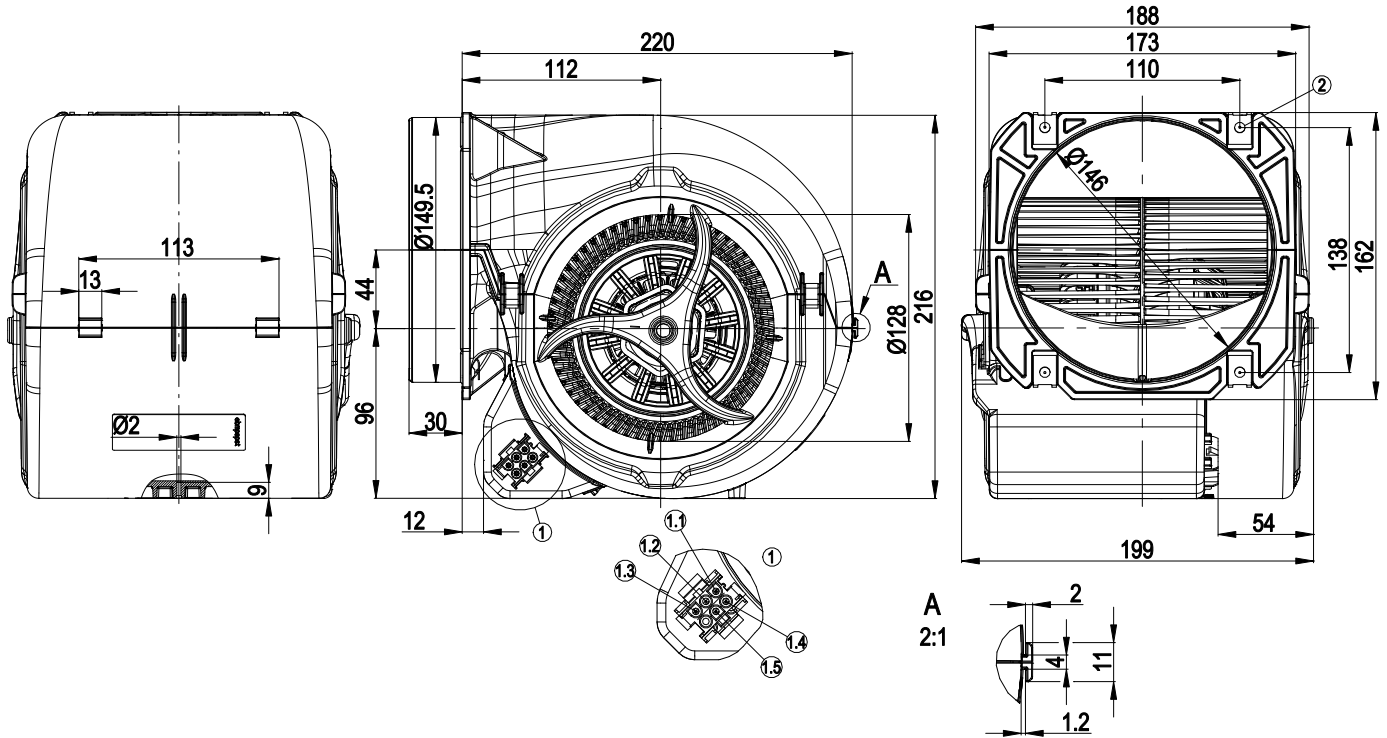

1	AMP Universal Mate-N-Lok coded plug system; connector shell: AMP 926 682-3; 5x plug pin: AMP 926 886-1
1.1	L = stage 1
1.2	L = step 2
1.3	L = stage 3
1.4	L = stage 4
1.5	N
2	4 x sheet metal nut for thread EN ISO 1478-ST4.8 (min. screw length 14.5 mm plus thickness of mounting material)



Connection screen

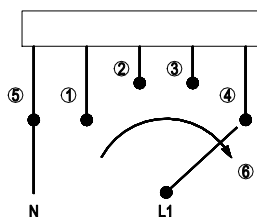

When changing speeds, switch must break the circuit

1	Stage 1(min.), white
2	Stage 2, red
3	Stage 3, grey
4	Stage 4 (max.), black
5	N, blue
6	Speed increase

Charts: Air flow 50 Hz

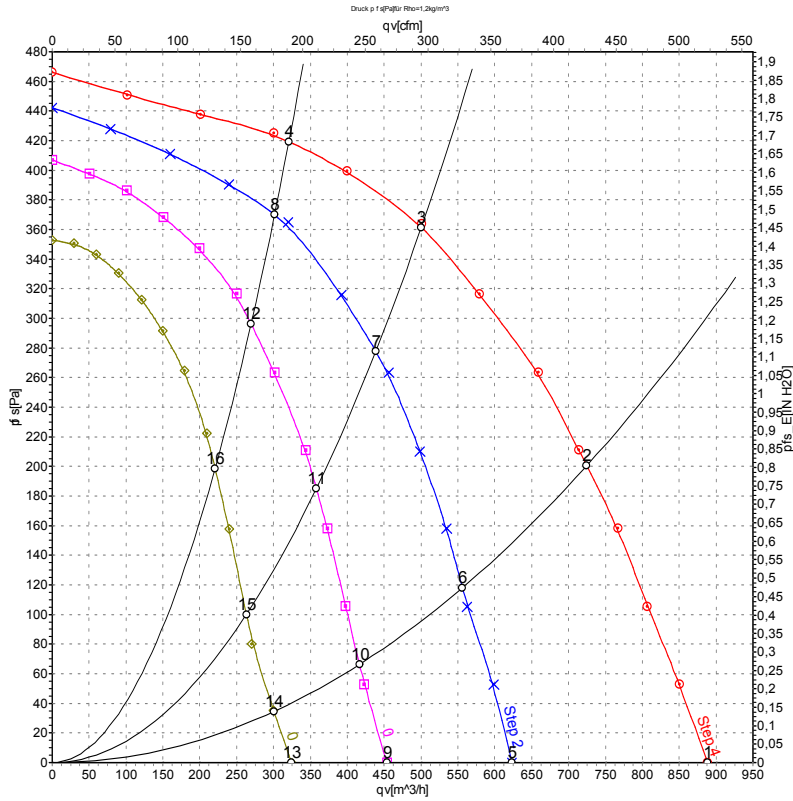

Measurement: LU-74465-1
 Measurement: LU-74466-1
 Measurement: LU-74467-1
 Measurement: LU-74468-1

Air performance measured as per ISO 5801 Installation category A. For detailed information on the measuring set-up, please contact ebm-papst. Suction-side noise levels: LwA measured as per ISO 13347 / LpA measured with 1m distance to fan axis. The values given are valid under the measuring conditions mentioned above and may vary according to the actual installation situation. With any deviation from the standard set-up, the specific values have to be checked and reviewed with the unit installed.

Measured values

	Stage	U	f	n	P _e	I	qv	p _{fs}	qv	p _{fs}
		V	Hz	min ⁻¹	W	A	m ³ /h	Pa	CFM	inH2O
1	4	230	50	1700	260	1.15	890	0	525	0.00
2	4	230	50	2140	232	1.00	725	200	425	0.80
3	4	230	50	2440	200	0.87	500	360	295	1.45
4	4	230	50	2620	176	0.76	320	420	190	1.69
5	3	230	50	1235	180	0.83	625	0	365	0.00
6	3	230	50	1670	167	0.80	555	118	325	0.47
7	3	230	50	2145	142	0.72	440	278	260	1.12
8	3	230	50	2450	118	0.64	300	371	175	1.49
9	2	230	50	915	147	0.70	455	0	265	0.00
10	2	230	50	1235	142	0.69	415	66	245	0.26
11	2	230	50	1755	128	0.64	360	185	210	0.74
12	2	230	50	2205	106	0.58	270	296	160	1.19
13	1	230	50	680	125	0.61	325	0	190	0.00
14	1	230	50	910	122	0.60	300	34	175	0.14
15	1	230	50	1295	117	0.58	265	99	155	0.40
16	1	230	50	1820	102	0.54	220	199	130	0.80

U = Supply voltage · f = Frequency · n = Speed (rpm) · P_e = Power input · I = Current draw · qv = Air flow · p_{fs} = Pressure increase

