

D2E146-HR01-89

AC centrifugal fan

forward curved, dual inlet
with housing (flange)



D2E146-HR01-89 ebmpapst Datasheet
sales@fansco.com
www.fansco.com

Limited partnership · Headquarters Muldingen
County court Stuttgart · HRA 590344

General partner Elektrobau Muldingen GmbH · Headquarters Muldingen
County court Stuttgart · HRB 590142

Nominal data

Type	D2E146-HR01-89	
Motor	M2E068-CF	
Phase		1~
Nominal voltage	VAC	240
Nominal voltage range	VAC	220 .. 240
Frequency	Hz	50
Type of data definition		ml
Valid for approval / standard		CE
Speed (rpm)	min ⁻¹	1720
Power input	W	220
Current draw	A	0.93
Motor capacitor	µF	5
Capacitor voltage	VDB	450
Capacitor standard		P2 (CE)
Min. back pressure	Pa	100
Min. ambient temperature	°C	-20
Max. ambient temperature	°C	45

ml = Max. load · me = Max. efficiency · fa = Running at free air · cs = Customer specs · cu = Customer unit
Subject to alterations



AC centrifugal fan

forward curved, dual inlet
with housing (flange)

Technical features

Mass	2.5 kg
Size	146 mm
Material of impeller	PP plastic
Housing material	PP plastic, black
Motor suspension	Motor mounted vibration-free on both sides
Direction of rotation	Counter-clockwise, seen on rotor
Type of protection	IP 20
Insulation class	"F"
Humidity (F)/environmental protection class (H)	H0 - dry environment
Max. permissible ambient motor temp. (transp./ storage)	+ 80 °C
Min. permissible ambient motor temp. (transp./storage)	- 40 °C
Mounting position	Any
Condensate discharge holes	None, open rotor
Operation mode	S1
Motor bearing	Calotte bearing
Speed steps	4
Touch current acc. IEC 60990 (measuring network Fig. 4, TN system)	< 0.75 mA
Electrical leads	With plug; Via terminal box, integrated capacitor connected via terminal box
Motor protection	Thermal overload protector (TOP) wired internally
Cable exit	Variable
Product conforming to standard	EN 60335-1; CE
Approval	VDE



AC centrifugal fan

forward curved, dual inlet
with housing (flange)

Product drawing

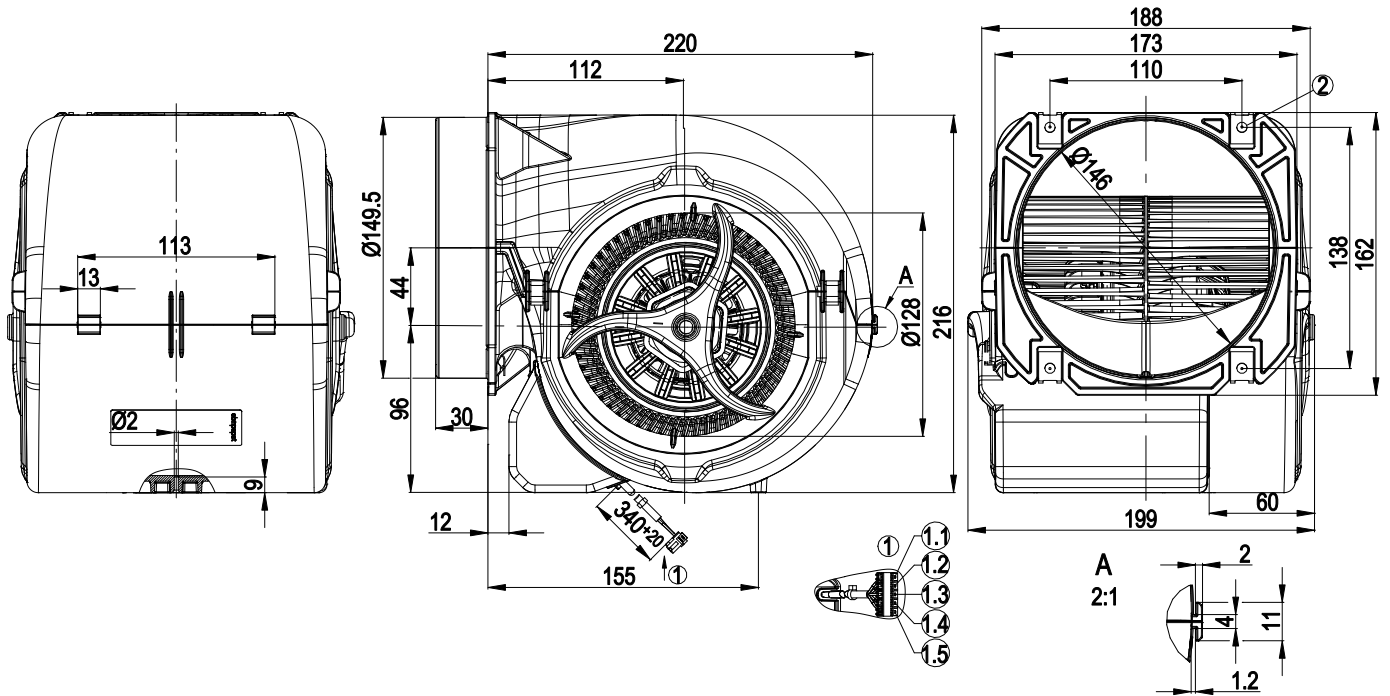

1	Connection line ETFE AWG22, Stocko spring housing MFMP 7262-005-008-960-000-00-G
1.1	N (blue)
1.2	L = step 4 (black)
1.3	L = step 3 (grey)
1.4	L = step 2 (red)
1.5	L = step 1 (white)
2	4 x sheet metal nut for thread EN ISO 1478-ST4.8 (min. screw length 14.5 mm plus thickness of mounting material)



Connection screen

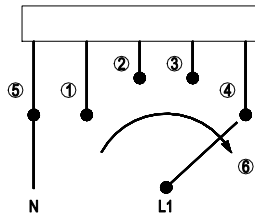

When changing speeds, switch must break the circuit

1	Stage 1(min.), white
2	Stage 2, red
3	Stage 3, grey
4	Stage 4 (max.), black
5	N, blue
6	Speed increase

AC centrifugal fan

forward curved, dual inlet

with housing (flange)

Charts: Air flow 50 Hz

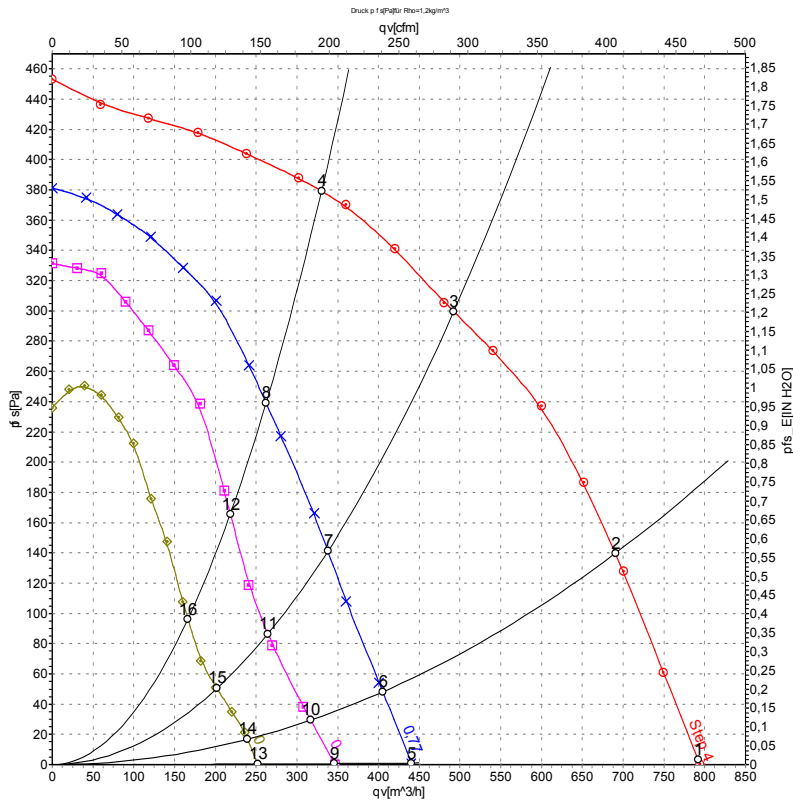

Measurement: LU-121510-1
 Measurement: LU-121512-1
 Measurement: LU-121513-1
 Measurement: LU-121514-1

Air performance measured as per ISO 5801 Installation category A. For detailed information on the measuring set-up, please contact ebm-papst. Suction-side noise levels: LwA measured as per ISO 13347 / LpA measured with 1m distance to fan axis. The values given are valid under the measuring conditions mentioned above and may vary according to the actual installation situation. With any deviation from the standard set-up, the specific values have to be checked and reviewed with the unit installed.

Measured values

	Stage	U	f	n	P _e	I	qv	p _{fs}	qv	p _{fs}
		V	Hz	min ⁻¹	W	A	m ³ /h	Pa	CFM	inH2O
1	4	230	50	1365	220	0.93	790	0	465	0.00
2	4	230	50	1765	200	0.87	690	140	405	0.56
3	4	230	50	2215	176	0.77	490	300	290	1.20
4	4	230	50	2455	157	0.68	330	380	195	1.53
5		230	50	790	129	0.62	440	0	260	0.00
6		230	50	1030	125	0.61	405	48	240	0.19
7		230	50	1540	116	0.58	340	141	200	0.57
8		230	50	1995	101	0.53	260	239	155	0.96
9		230	50	630	113	0.55	345	0	205	0.00
10		230	50	835	110	0.54	315	29	185	0.12
11		230	50	1235	106	0.53	265	86	155	0.35
12		230	50	1680	97	0.50	220	166	130	0.67
13		230	50	470	98	0.49	250	0	150	0.00
14		230	50	625	97	0.49	240	18	140	0.07
15		230	50	905	94	0.48	200	50	120	0.20
16		230	50	1235	90	0.47	165	96	100	0.39

U = Supply voltage · f = Frequency · n = Speed (rpm) · P_e = Power input · I = Current draw · qv = Air flow · p_{fs} = Pressure increase

