

# AC centrifugal fan

forward-curved, dual-intake  
with housing (without flange)

D2E146-AZ03-E7 ebmpapst Datasheet

sales@fansco.com

www.fansco.com

## Nominal data

<b>Type</b>	<b>D2E146-AZ03-E7</b>	
<b>Motor</b>	<b>M2E074-EI</b>	
Phase		1~
Nominal voltage	VAC	230
Frequency	Hz	50
Method of obtaining data		ml
Valid for approval/standard		-
Speed (rpm)	min <sup>-1</sup>	2300
Power consumption	W	330
Current draw	A	1.44
Capacitor	μF	7
Capacitor voltage	VDB	400
Capacitor standard		S2 (CE)
Min. back pressure	Pa	235
Min. back pressure	in. wg	0.94
Min. ambient temperature	°C	-25
Max. ambient temperature	°C	65

ml = Max. load · me = Max. efficiency · fa = Free air · cs = Customer specification · ce = Customer equipment  
Subject to change



# AC centrifugal fan

forward-curved, dual-intake  
with housing (without flange)

## Technical description

Weight	5.5 kg
Size	146 mm
Motor size	74
Rotor surface	Unpainted
Impeller material	Sheet steel, galvanized
Housing material	Sheet steel, galvanized
Guard grille material	Steel, galvanized and coated with white-aluminum plastic (RAL 9006)
Motor suspension	Motor vibration-damped on one side
Direction of rotation	Counterclockwise, viewed toward rotor
Degree of protection	IP44
Insulation class	"F"
Moisture (F) / Environmental (H) protection class	H0 - dry environment
Max. permitted ambient temp. for motor (transport/storage)	+80 °C
Min. permitted ambient temp. for motor (transport/storage)	-40 °C
Installation position	Any
Condensation drainage holes	None
Mode	S1
Motor bearing	Ball bearing
Touch current according to IEC 60990 (measuring circuit Fig. 4, TN system)	< 0.75 mA
Motor protection	Thermal overload protector (TOP) internally connected
Protection class	I (with customer connection of protective earth)
Motor capacitor according to EN 60252-1 in safety protection class	S2
Conformity with standards	EN 60335-1
Comment on CE	Commissioning not permitted in the European Economic Area



D2E146-AZ03-E7

# AC centrifugal fan

forward-curved, dual-intake  
with housing (without flange)

## Product drawing

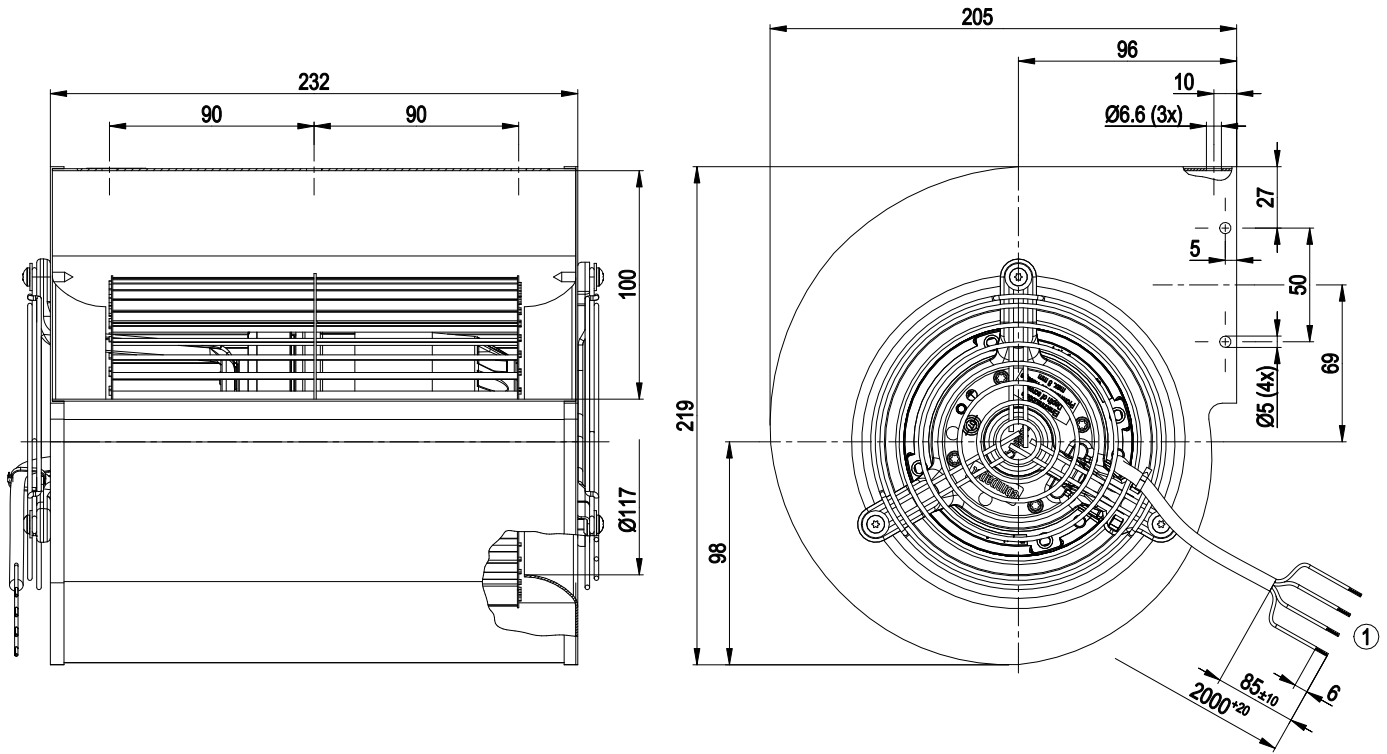

1 Cable PVC 4G 0.5 mm<sup>2</sup>, 4x crimped splices

## Connection diagram

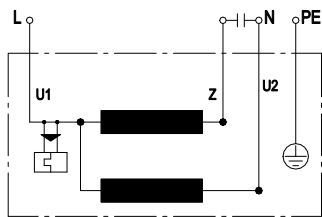

U1	blue	Z	brown	U2	black
PE	green/yellow				



# AC centrifugal fan

forward-curved, dual-intake  
with housing (without flange)

## Curves: Air performance 50 Hz

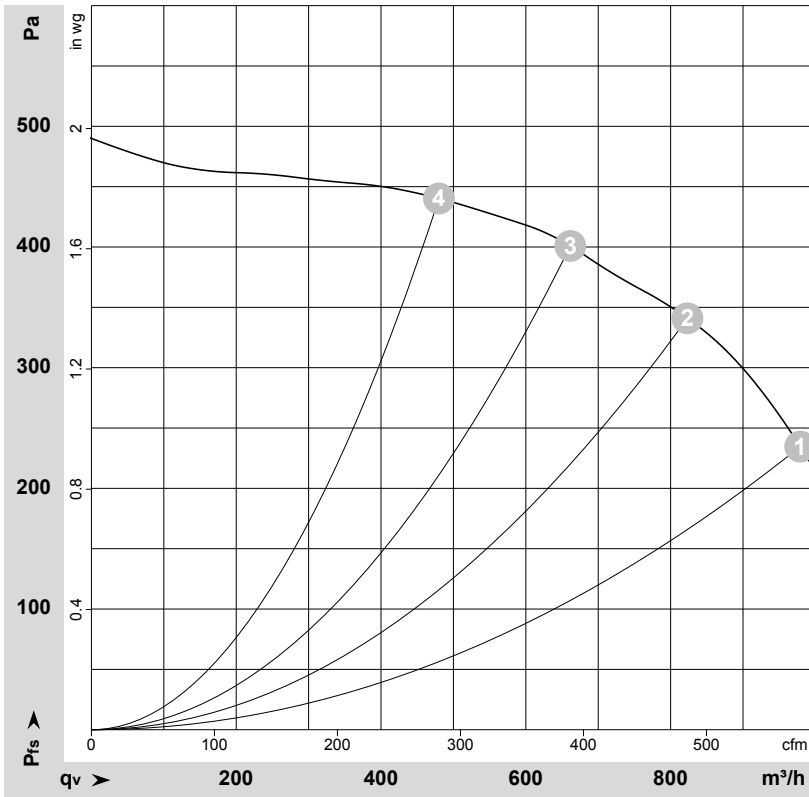

$\rho = 1.15 \text{ kg/m}^3 \pm 2 \%$

Measurement: LU-166694-1

Air performance measured according to ISO 5801 installation category A. For detailed information on the measurement setup, contact ebmpapst. Intake sound level: Sound power level according to ISO 13347 / sound pressure level measured at 1 m distance from fan axis. The values given are valid under the specified measuring conditions and may vary due to conditions of installation. For deviations from the standard configuration, the parameters have to be checked on the installed unit.

## Measured values

	U	f	n	P <sub>e</sub>	I	LpA <sub>in</sub>	LwA <sub>in</sub>	q <sub>v</sub>	p <sub>fs</sub>	q <sub>v</sub>	p <sub>fs</sub>
	V	Hz	min <sup>-1</sup>	W	A	dB(A)	dB(A)	m <sup>3</sup> /h	Pa	cfm	in. wg
1	230	50	2300	330	1.44	64	75	980	235	575	0.94
2	230	50	2500	272	1.19	64	75	825	340	485	1.36
3	230	50	2625	234	1.03	64	75	660	400	390	1.61
4	230	50	2720	198	0.88	65	75	480	440	285	1.77

U = Voltage · f = Frequency · n = Speed (rpm) · P<sub>e</sub> = Power consumption · I = Current draw · LpA<sub>in</sub> = Sound pressure level intake side · LwA<sub>in</sub> = Sound power level intake side  
q<sub>v</sub> = Air flow · p<sub>fs</sub> = Pressure increase

