

AC centrifugal fan

forward curved, dual inlet
with housing (without flange)

D2E146-AP47-76 ebmpapst Datasheet FansCo

sales@fansco.com

www.fansco.com

Nominal data

Type	D2E146-AP47-76		
Motor	M2E068-EC		
Phase		1~	1~
Nominal voltage	VAC	230	230
Frequency	Hz	50	60
Type of data definition		ml	ml
Valid for approval / standard		CE	CE
Speed	min ⁻¹	2050	2550
Power input	W	300	330
Current draw	A	1.31	1.45
Motor capacitor	μF	8	8
Capacitor voltage	VDB	400	400
Min. back pressure	Pa	200	400
Min. ambient temperature	°C	-25	-25
Max. ambient temperature	°C	50	45

ml = max. load · me = max. efficiency · fa = running at free air · cs = customer specs · cu = customer unit
Subject to alterations

Data according to ErP directive

Installation category	A	Overall efficiency η_{es}	Actual	Request 2013	Request 2015
Efficiency category	Static	Efficiency grade N	28.2	26.8	33.8
Variable speed drive	No	Power input P_e	38.4	37	44
Specific ratio*	1.00	kW	0.24		
		Air flow q_v	m ³ /h	705	
		Pressure increase p_{fs}	Pa	351	
		Speed n	min ⁻¹	2435	

Data established at point of optimum efficiency



AC centrifugal fan

forward curved, dual inlet
with housing (without flange)

Technical features

Mass	4.3 kg
Size	146 mm
Surface of rotor	Coated in black
Material of impeller	Sheet steel, galvanised
Housing material	Sheet steel, galvanised
Motor suspension	Motor mounted via brackets on one side
Direction of rotation	Counter-clockwise, seen on rotor
Type of protection	IP 44; Depending on installation and position as per EN 60034-5
Insulation class	"F"
Humidity class	F1-2
Max. permissible ambient motor temp. (transp./ storage)	+ 80 °C
Min. permissible ambient motor temp. (transp./storage)	- 40 °C
Mounting position	Any
Condensate discharge holes	Rotor-side
Operation mode	S1
Motor bearing	Ball bearing
Touch current acc. IEC 60990 (measuring network Fig. 4, TN system)	< 0.75 mA
Motor protection	Thermal overload protector (TOP) wired internally
Cable exit	Axial
Protection class	I (if protective earth is connected by customer)
Product conforming to standard	EN 60335-1; CE



D2E146-AP47-76

AC centrifugal fan

forward curved, dual inlet
with housing (without flange)

Product drawing

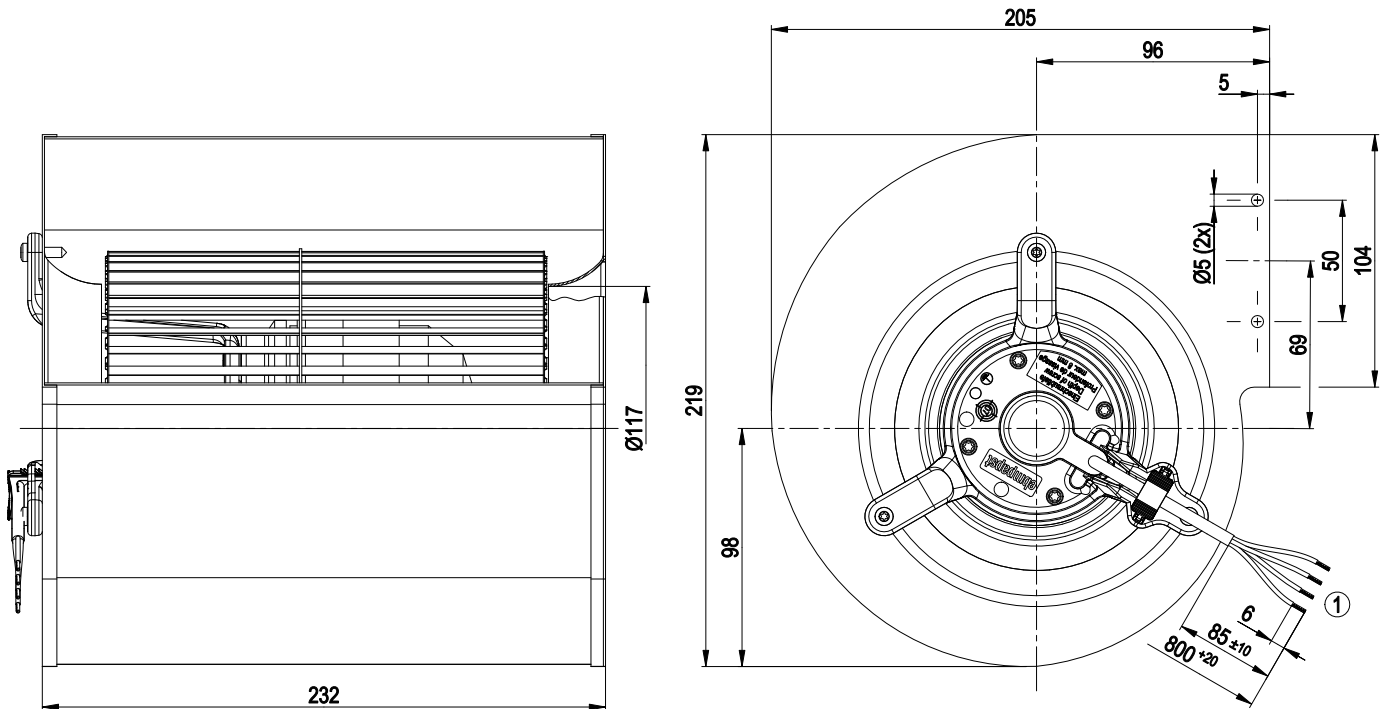

1 Connection line silicone 4G 0.5 mm², 4x brass lead tips crimped

Connection screen

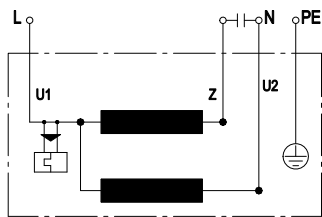

U1	blue	Z	brown	U2	black
PE	green/yellow				



AC centrifugal fan

forward curved, dual inlet
with housing (without flange)

Charts: Air flow 50 Hz Y

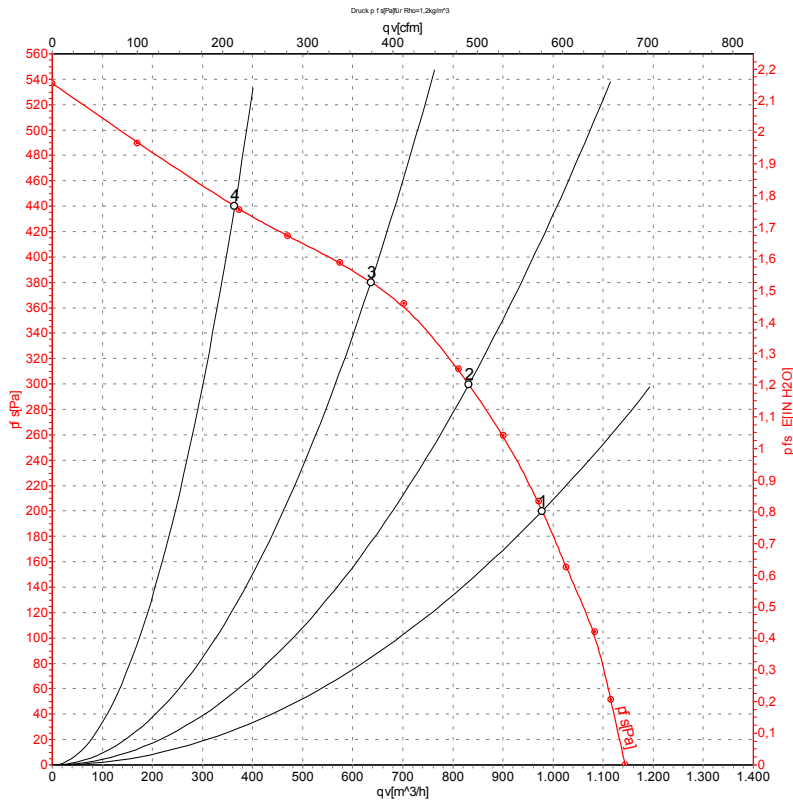

Measurement: LU-32744

Air performance measured as per ISO 5801 Installation category A. For detailed information on the measuring set-up, please contact ebmpapst. Suction-side noise levels: LwA measured as per ISO 13347 / LpA measured with 1m distance to fan axis. The values given are valid under the measuring conditions mentioned above and may vary according to the actual installation situation. With any deviation from the standard set-up, the specific values have to be checked and reviewed with the unit installed.

Measured values

	Conn.	U	f	n	P _e	I	qv	P _{fs}
		V	Hz	min ⁻¹	W	A	m ³ /h	Pa
1	Y	230	50	2050	300	1.31	970	200
2	Y	230	50	2265	267	1.18	830	300
3	Y	230	50	2490	232	1.02	635	380
4	Y	230	50	2675	191	0.84	365	440

Conn. = Connection · U = Supply voltage · f = Frequency · n = Speed · P_e = Power input · I = Current draw · qv = Air flow · P_{fs} = Pressure increase



AC centrifugal fan

forward curved, dual inlet
with housing (without flange)

Charts: Air flow 60 Hz Y

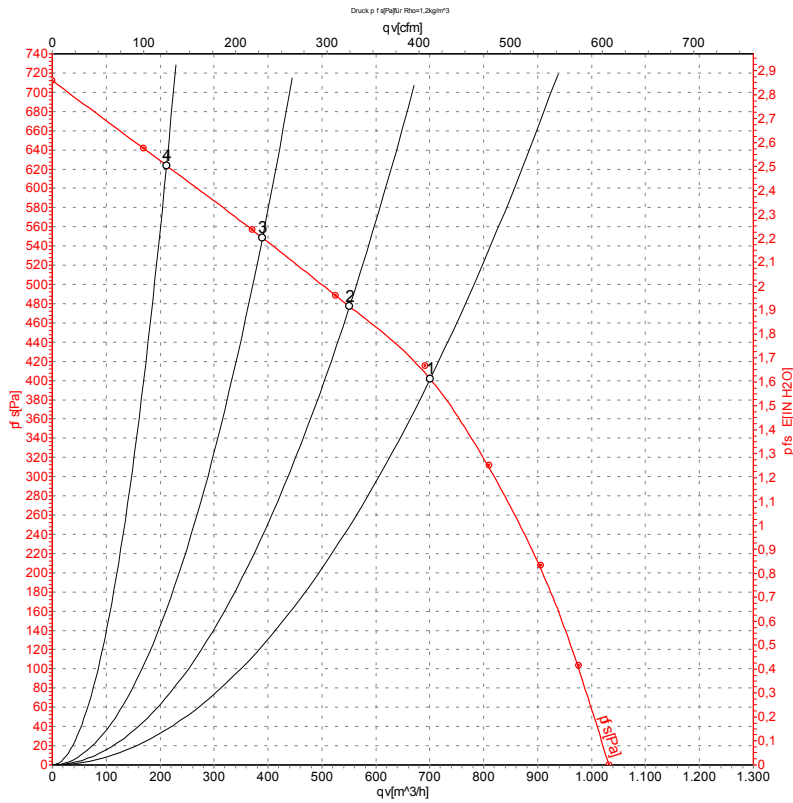

Measurement: LU-32745

Air performance measured as per ISO 5801 Installation category A. For detailed information on the measuring set-up, please contact ebm-papst. Suction-side noise levels: LwA measured as per ISO 13347 / LpA measured with 1m distance to fan axis. The values given are valid under the measuring conditions mentioned above and may vary according to the actual installation situation. With any deviation from the standard set-up, the specific values have to be checked and reviewed with the unit installed.

Measured values

	Conn.	U	f	n	P _e	I	qv	p _{fs}
		V	Hz	min ⁻¹	W	A	m ³ /h	Pa
1	Y	230	60	2550	330	1.45	700	400
2	Y	230	60	2770	300	1.36	550	475
3	Y	230	60	2975	277	1.28	390	550
4	Y	230	60	3095	260	1.22	210	625

Conn. = Connection · U = Supply voltage · f = Frequency · n = Speed · P_e = Power input · I = Current draw · qv = Air flow · p_{fs} = Pressure increase

