

D2E146-AP43-C9

AC centrifugal fan

forward curved, dual inlet

with housing (flange)



D2E146-AP43-C9 ebmpapst Datasheet FansCo

sales@fansco.com

www.fansco.com

Nominal data

Type	D2E146-AP43-C9		
Motor	M2E068-EC		
Phase		1~	1~
Nominal voltage	VAC	230	230
Frequency	Hz	50	60
Type of data definition		ml	ml
Valid for approval / standard		CE	CE
Speed	min ⁻¹	1650	2100
Power input	W	245	270
Current draw	A	1.08	1.20
Motor capacitor	µF	6	6
Capacitor voltage	VDB	400	400
Capacitor standard		P0 (CE)	P0 (CE)
Min. back pressure	Pa	100	250
Max. ambient temperature	°C	50	45
Starting current	A	1.2	1.22

ml = max. load · me = max. efficiency · fa = running at free air · cs = customer specs · cu = customer unit
Subject to alterations

Data according to ErP directive

Installation category	A
Efficiency category	Static
Variable speed drive	No
Specific ratio*	1.00

* Specific ratio = $1 + p_g / 100\,000\text{ Pa}$

	Actual	Request 2013	Request 2015
Overall efficiency η_{es}	27.3	26	33
Efficiency grade N	38.3	37	44
Power input P_e	kW	0.18	
Air flow q_v	m ³ /h	560	
Pressure increase p_{fs}	Pa	335	
Speed n	min ⁻¹	2375	

Data established at point of optimum efficiency



AC centrifugal fan

forward curved, dual inlet
with housing (flange)

Technical features

Mass	4.6 kg
Size	146 mm
Surface of rotor	Coated in black
Material of impeller	Sheet steel, galvanised
Housing material	Sheet steel, hot-galvanised
Motor suspension	Motor mounted via brackets on one side
Direction of rotation	Counter-clockwise, seen on rotor
Type of protection	IP 44; Depending on installation and position as per EN 60034-5
Insulation class	"F"
Humidity class	F2-2
Max. permissible ambient motor temp. (transp./ storage)	+ 80 °C
Min. permissible ambient motor temp. (transp./storage)	- 40 °C
Mounting position	Shaft horizontal or rotor on bottom; rotor on top on request
Condensate discharge holes	Rotor-side
Operation mode	S1
Motor bearing	Ball bearing
Touch current acc. IEC 60990 (measuring network Fig. 4, TN system)	< 0.75 mA
Motor protection	Thermal overload protector (TOP) wired internally
Cable exit	Axial
Protection class	I (if protective earth is connected by customer)
Product conforming to standard	EN 60335-1; CE
Approval	CCC



AC centrifugal fan

forward curved, dual inlet
with housing (flange)

Product drawing

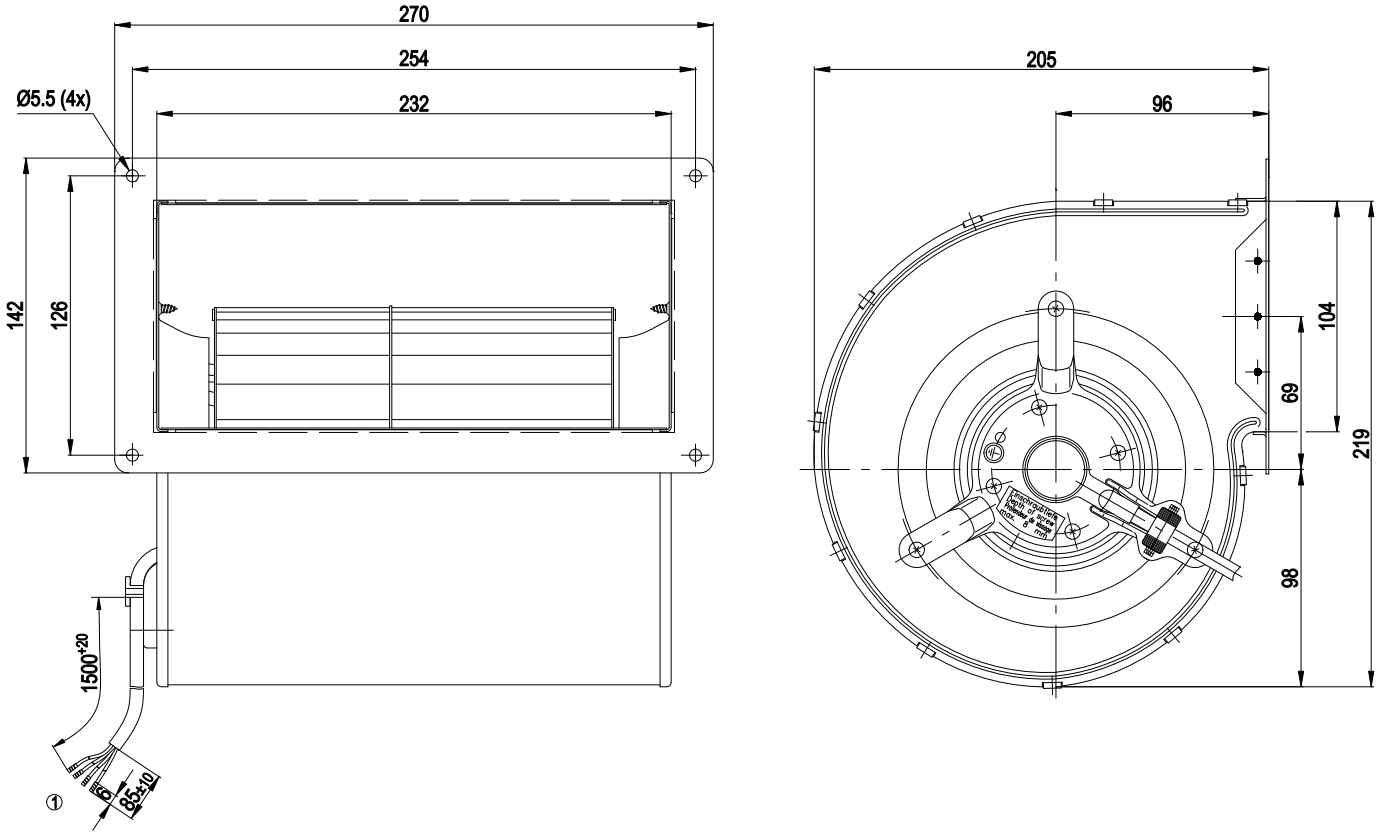

1 Connection line silicone 4G 1.0 mm², 4 x brass lead tips crimped

Connection screen

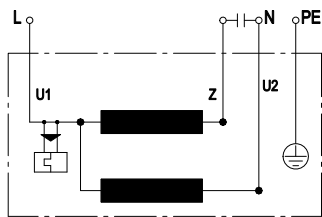

U1	blue	Z	brown	U2	black
PE	green/yellow				



AC centrifugal fan

forward curved, dual inlet
with housing (flange)

Charts: Air flow 50 Hz

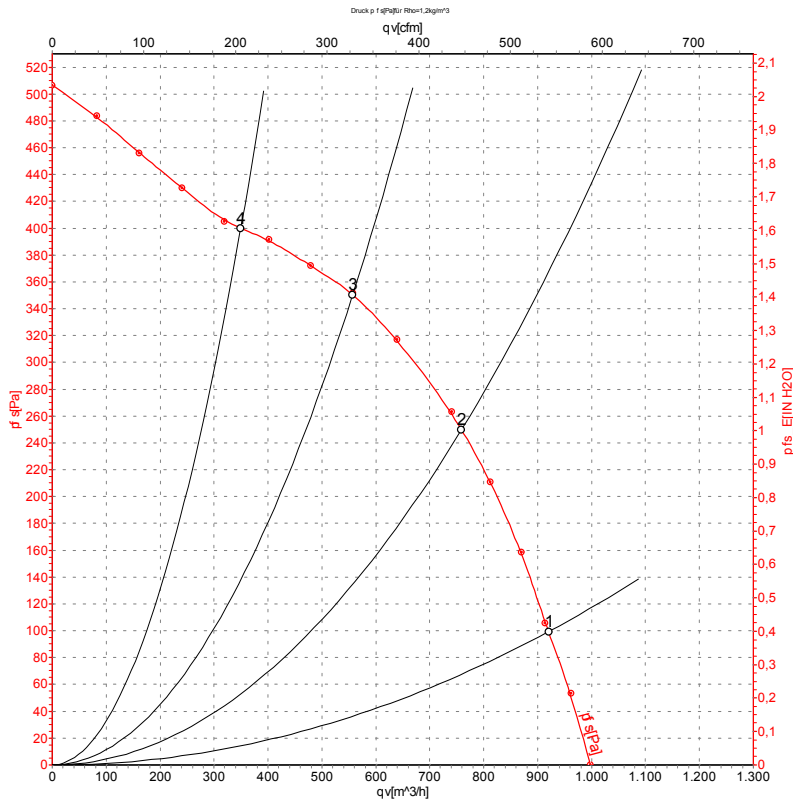

Measurement: LU-105291

Air performance measured as per ISO 5801 Installation category A. For detailed information on the measuring set-up, please contact ebm-papst. Suction-side noise levels: L_{WA} measured as per ISO 13347 / L_{pA} measured with 1m distance to fan axis. The values given are valid under the measuring conditions mentioned above and may vary according to the actual installation situation. With any deviation from the standard set-up, the specific values have to be checked and reviewed with the unit installed.

Measured values

	U	f	n	P _e	I	qv	P _{fs}
	V	Hz	min ⁻¹	W	A	m³/h	Pa
1	230	50	1650	245	1.08	920	100
2	230	50	2020	219	0.96	760	250
3	230	50	2380	190	0.84	555	350
4	230	50	2560	168	0.75	350	400

U = Supply voltage · f = Frequency · n = Speed · P_e = Power input · I = Current draw · qv = Air flow · P_{fs} = Pressure increase



Charts: Air flow 60 Hz

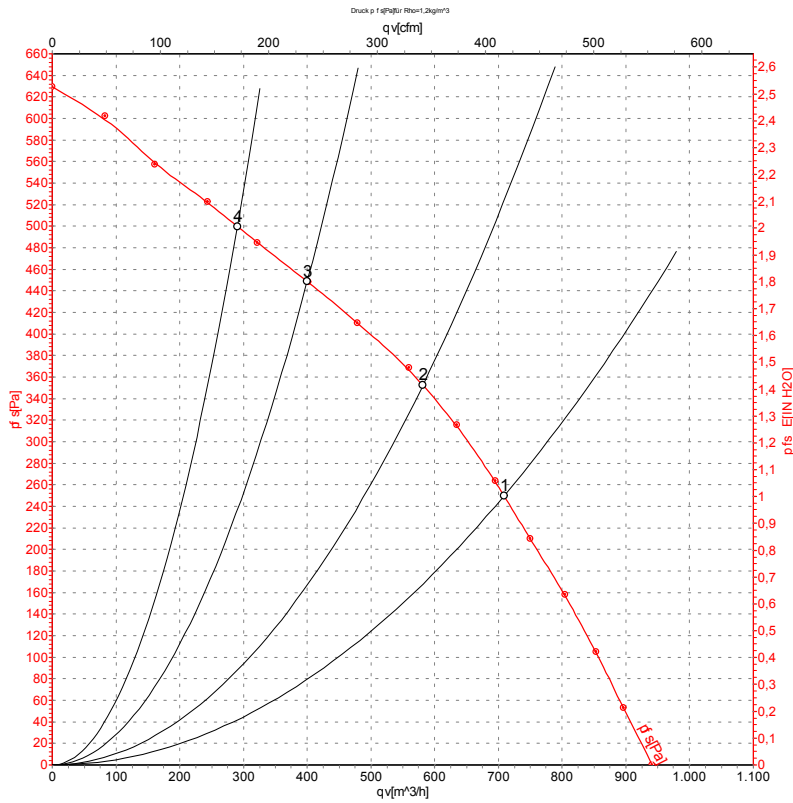

Measurement: LU-105293

Air performance measured as per ISO 5801 Installation category A. For detailed information on the measuring set-up, please contact ebm-papst. Suction-side noise levels: L_{wA} measured as per ISO 13347 / L_{pA} measured with 1m distance to fan axis. The values given are valid under the measuring conditions mentioned above and may vary according to the actual installation situation. With any deviation from the standard set-up, the specific values have to be checked and reviewed with the unit installed.

Measured values

	U	f	n	P _e	I	q _v	P _{fs}
	V	Hz	min ⁻¹	W	A	m ³ /h	Pa
1	230	60	2100	270	1.20	710	250
2	230	60	2360	254	1.11	580	350
3	230	60	2705	241	1.07	400	450
4	230	60	2815	236	1.05	290	500

U = Supply voltage · f = Frequency · n = Speed · P_e = Power input · I = Current draw · q_v = Air flow · P_{fs} = Pressure increase

