

D2E140-HR97-07

# AC centrifugal fan

forward-curved, dual-intake

with housing (flange)



D2E140-HR97-07 ebmpapst Datasheet FansCo

sales@fansco.com

www.fansco.com

## Nominal data

Type	D2E140-HR97-07		
Motor	M2E068-CF		
Phase		1~	1~
Nominal voltage	VAC	230	230
Frequency	Hz	50	60
Method of obtaining data		fa	fa
Valid for approval/standard		CE	CE
Speed (rpm)	min <sup>-1</sup>	1150	1050
Power consumption	W	130	130
Current draw	A	0.58	0.58
Capacitor	µF	2	2
Capacitor voltage	VDB	400	400
Capacitor standard		S2 (CE)	S2 (CE)
Min. back pressure	Pa	0	0
Min. back pressure	inH2O	0	0
Min. ambient temperature	°C	-25	-25
Max. ambient temperature	°C	50	40
Starting current	A	0.57	0.59

ml = Max. load · me = Max. efficiency · fa = Free air · cs = Customer specification · ce = Customer equipment  
Subject to change



# AC centrifugal fan

forward-curved, dual-intake

with housing (flange)

## Technical description

<b>Weight</b>	2.3 kg
<b>Fan size</b>	140 mm
<b>Rotor surface</b>	Unpainted
<b>Impeller material</b>	PP plastic
<b>Housing material</b>	PP plastic
<b>Motor suspension</b>	Motor mounted with brackets on one side
<b>Direction of rotation</b>	Clockwise, viewed toward rotor
<b>Degree of protection</b>	IP44
<b>Insulation class</b>	"F"
<b>Moisture (F) / Environmental (H) protection class</b>	H0 - dry environment
<b>Max. permitted ambient temp. for motor (transport/storage)</b>	+ 80 °C
<b>Min. permitted ambient temp. for motor (transport/storage)</b>	- 40 °C
<b>Installation position</b>	Any
<b>Condensation drainage holes</b>	None
<b>Mode</b>	S1
<b>Motor bearing</b>	Ball bearing
<b>Speed levels</b>	4
<b>Touch current according to IEC 60990 (measuring circuit Fig. 4, TN system)</b>	< 0.75 mA
<b>Electrical hookup</b>	Via terminal box, capacitor integrated and connected; With plug
<b>Motor protection</b>	Thermal overload protector (TOP) internally connected
<b>With cable</b>	Variable
<b>Protection class</b>	I (with customer connection of protective earth)
<b>Motor capacitor according to EN 60252-1 in safety protection class</b>	S2
<b>Conformity with standards</b>	EN 60335-1; CE
<b>Approval</b>	VDE; EAC; CCC



D2E140-HR97-07

# AC centrifugal fan

forward-curved, dual-intake  
with housing (flange)

## Product drawing

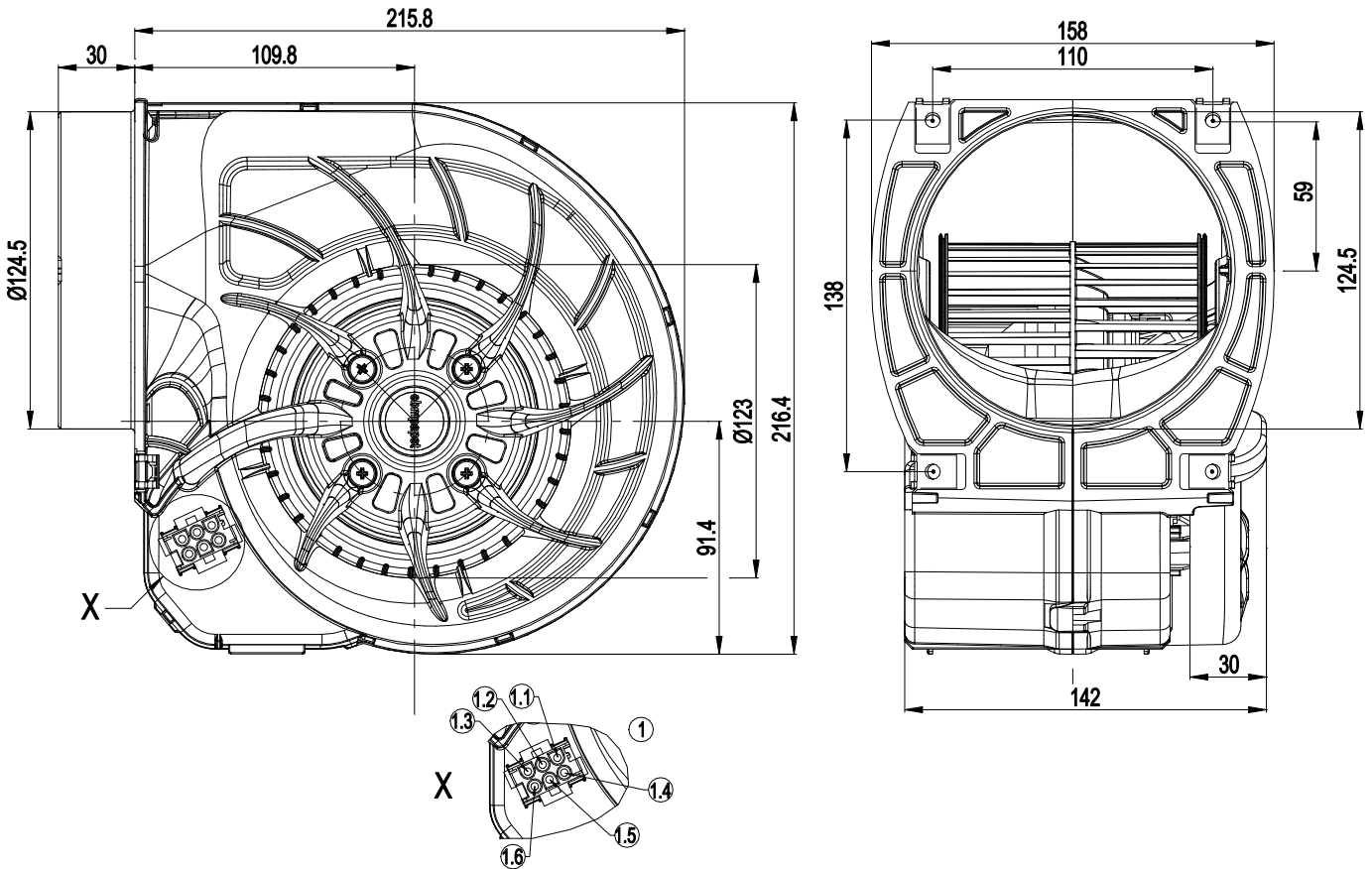

1	Connector housing AMP Mate-N-Lok 350 715-4
1.1	L = step 1
1.2	L = step 2
1.3	L = step 3
1.4	L = step 4 (max.)
1.5	N
1.6	Protective earth



## Connection diagram

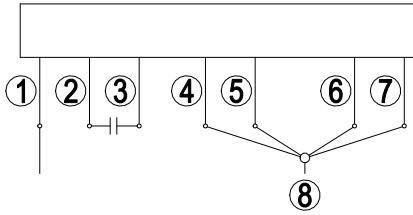

Note: High speed (step IV); low speed (step I); the switch must interrupt the circuit when switching.

1	= N = blue
2	brown
3	yellow
4	Step I black 1 / white
5	Step II black 2 / red
6	Step III black 3 / gray
7	Step IV black 4 / black
8	L1

## Curves: Air performance 50 Hz

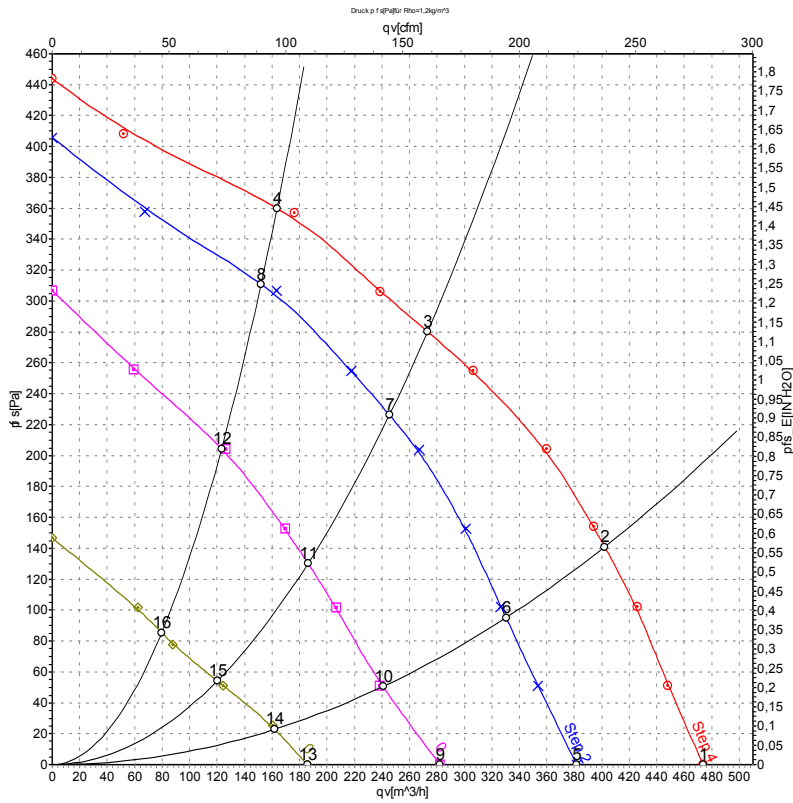

Measurement: LU-43529-1  
 Measurement: LU-43530-1  
 Measurement: LU-43531-1  
 Measurement: LU-43532-1

Air performance measured according to ISO 5801 installation category A. For detailed information on the measurement setup, contact ebm-papst. Intake sound level: Sound power level according to ISO 13347 / sound pressure level measured at 1 m distance from fan axis. The values given are valid under the specified measuring conditions and may vary due to conditions of installation. For deviations from the standard configuration, the parameters have to be checked on the installed unit.

## Measured values

	Stage	U	f	n	P <sub>e</sub>	I	LpA <sub>in</sub>	LwA <sub>in</sub>	q <sub>v</sub>	P <sub>fs</sub>	q <sub>v</sub>	P <sub>fs</sub>
		V	Hz	min <sup>-1</sup>	W	A	dB(A)	dB(A)	m <sup>3</sup> /h	Pa	cfm	inH2O
1	4	230	50	1150	130	0.58	58	70	475	0	280	0.00
2	4	230	50	1705	117	0.51	57	69	400	140	235	0.56
3	4	230	50	2220	100	0.43	59	71	275	280	160	1.12
4	4	230	50	2390	92	0.40	60	72	165	360	95	1.45
5	3	230	50	955	97	0.43	52	64	380	0	225	0.00
6	3	230	50	1415	92	0.41	53	65	330	95	195	0.38
7	3	230	50	1995	81	0.36	56	69	245	226	145	0.91
8	3	230	50	2230	73	0.34	59	71	150	313	90	1.26
9	2	230	50	710	75	0.34	44	56	280	0	165	0.00
10	2	230	50	1020	73	0.33	45	57	240	48	140	0.19
11	2	230	50	1510	68	0.31	49	61	185	130	110	0.52
12	2	230	50	1815	63	0.30	54	66	125	206	70	0.83
13	1	230	50	490	57	0.26	35	47	185	0	110	0.00
14	1	230	50	705	56	0.26	36	48	160	24	95	0.10
15	1	230	50	1000	55	0.25	38	50	120	54	70	0.22
16	1	230	50	1185	54	0.25	43	55	80	85	45	0.34

U = Power supply · f = Frequency · n = Speed (rpm) · P<sub>e</sub> = Power consumption · I = Current draw · LpA<sub>in</sub> = Sound pressure level intake side · LwA<sub>in</sub> = Sound power level intake side  
 q<sub>v</sub> = Air flow · P<sub>fs</sub> = Pressure increase



# AC centrifugal fan

forward-curved, dual-intake

with housing (flange)

## Curves: Air performance 60 Hz

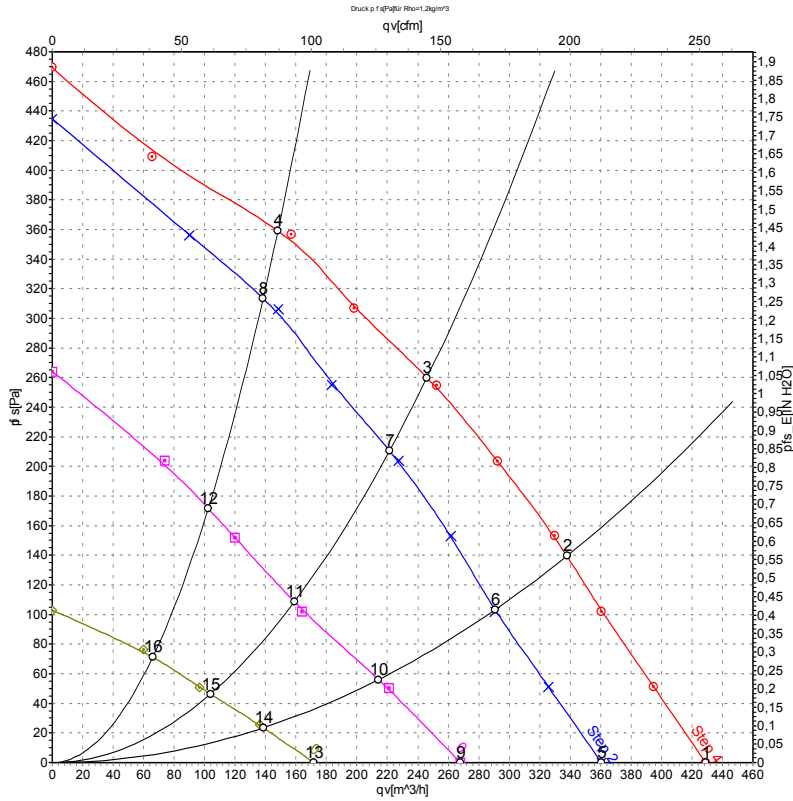

Measurement: LU-43534-1  
 Measurement: LU-43535-1  
 Measurement: LU-43536-1  
 Measurement: LU-43533-1

Air performance measured according to ISO 5801 installation category A. For detailed information on the measurement setup, contact ebmpapst. Intake sound level: Sound power level according to ISO 13347 / sound pressure level measured at 1 m distance from fan axis. The values given are valid under the specified measuring conditions and may vary due to conditions of installation. For deviations from the standard configuration, the parameters have to be checked on the installed unit.

## Measured values

	Stage	U	f	n	Pe	I	qv	Pfs	qv	Pfs
		V	Hz	min <sup>-1</sup>	W	A	m <sup>3</sup> /h	Pa	cfm	inH2O
1	4	230	60	1050	130	0.58	430	0	255	0.00
2	4	230	60	1635	127	0.56	340	140	200	0.56
3	4	230	60	2120	122	0.53	245	260	145	1.04
4	4	230	60	2380	118	0.51	150	360	85	1.45
5	3	230	60	905	100	0.44	360	0	210	0.00
6	3	230	60	1415	97	0.44	290	102	170	0.41
7	3	230	60	1920	93	0.43	220	211	130	0.85
8	3	230	60	2220	90	0.42	140	315	80	1.26
9	2	230	60	665	75	0.35	270	0	160	0.00
10	2	230	60	1045	73	0.34	215	57	125	0.23
11	2	230	60	1400	71	0.34	160	108	95	0.43
12	2	230	60	1675	70	0.34	100	172	60	0.69
13	1	230	60	455	56	0.27	170	0	100	0.00
14	1	230	60	700	55	0.27	140	24	80	0.10
15	1	230	60	925	54	0.27	105	46	60	0.18
16	1	230	60	1085	53	0.26	65	72	40	0.29

U = Power supply · f = Frequency · n = Speed (rpm) · Pe = Power consumption · I = Current draw · qv = Air flow · Pfs = Pressure increase

