

AC centrifugal fan

forward curved, dual inlet
with housing (without flange)

D2E133-DM64-I7 ebmpapst Datasheet
sales@fansco.com
www.fansco.com

Limited partnership · Headquarters Mulfingen
County court Stuttgart · HRA 590344

General partner Elektrobau Mulfingen GmbH · Headquarters Mulfingen
County court Stuttgart · HRB 590142

Nominal data

Type	D2E133-DM64-I7		
Motor	M2E068-DF		
Phase		1~	1~
Nominal voltage	VAC	230	230
Frequency	Hz	50	60
Type of data definition		ml	ml
Valid for approval / standard		CE	CE
Speed (rpm)	min ⁻¹	2200	2500
Power input	W	230	255
Current draw	A	1.05	1.12
Motor capacitor	µF	4	4
Capacitor voltage	VDB	400	400
Capacitor standard		S0 (CE)	S0 (CE)
Min. back pressure	Pa	200	300
Min. ambient temperature	°C	-25	-25
Max. ambient temperature	°C	50	50

ml = Max. load · me = Max. efficiency · fa = Running at free air · cs = Customer specs · cu = Customer unit
Subject to alterations

Data according to ErP directive

		Actual	Request 2015			
01 Overall efficiency η_{es}	%	32.6	32.6	09 Power input P_e	kW	0.16
02 Measurement category		A		09 Air flow q_v	m ³ /h	560
03 Efficiency category		Static		09 Pressure increase p_{fs}	Pa	343
04 Efficiency grade N		44	44	10 Speed (rpm) n	min ⁻¹	2535
05 Variable speed drive		No		11 Specific ratio*		1.00

Data definition with optimum efficiency.
The ErP data is determined using a motor-impeller combination in a standardised measurement configuration.

* Specific ratio = $1 + p_{fs} / 100\,000\text{ Pa}$

LU-150660



AC centrifugal fan

forward curved, dual inlet
with housing (without flange)

Technical features

Mass	3.7 kg
Size	133 mm
Surface of rotor	Coated in black
Material of impeller	Sheet steel, galvanised
Housing material	Sheet steel, galvanised
Motor suspension	Motor mounted via brackets on one side
Direction of rotation	Counter-clockwise, seen on rotor
Type of protection	IP 44; Depending on installation and position as per EN 60034-5
Insulation class	"F"
Humidity (F)/environmental protection class (H)	H0+
Max. permissible ambient motor temp. (transp./ storage)	+ 80 °C
Min. permissible ambient motor temp. (transp./storage)	- 40 °C
Mounting position	Shaft horizontal or rotor on bottom; rotor on top on request
Condensate discharge holes	Rotor-side
Operation mode	S1
Motor bearing	Ball bearing
Touch current acc. IEC 60990 (measuring network Fig. 4, TN system)	< 0.75 mA
Motor protection	Thermal overload protector (TOP) brought out, basic insulation
Cable exit	Axial
Protection class	I (if protective earth is connected by customer)
Product conforming to standard	EN 60335-1; CE



AC centrifugal fan

forward curved, dual inlet
with housing (without flange)

Product drawing

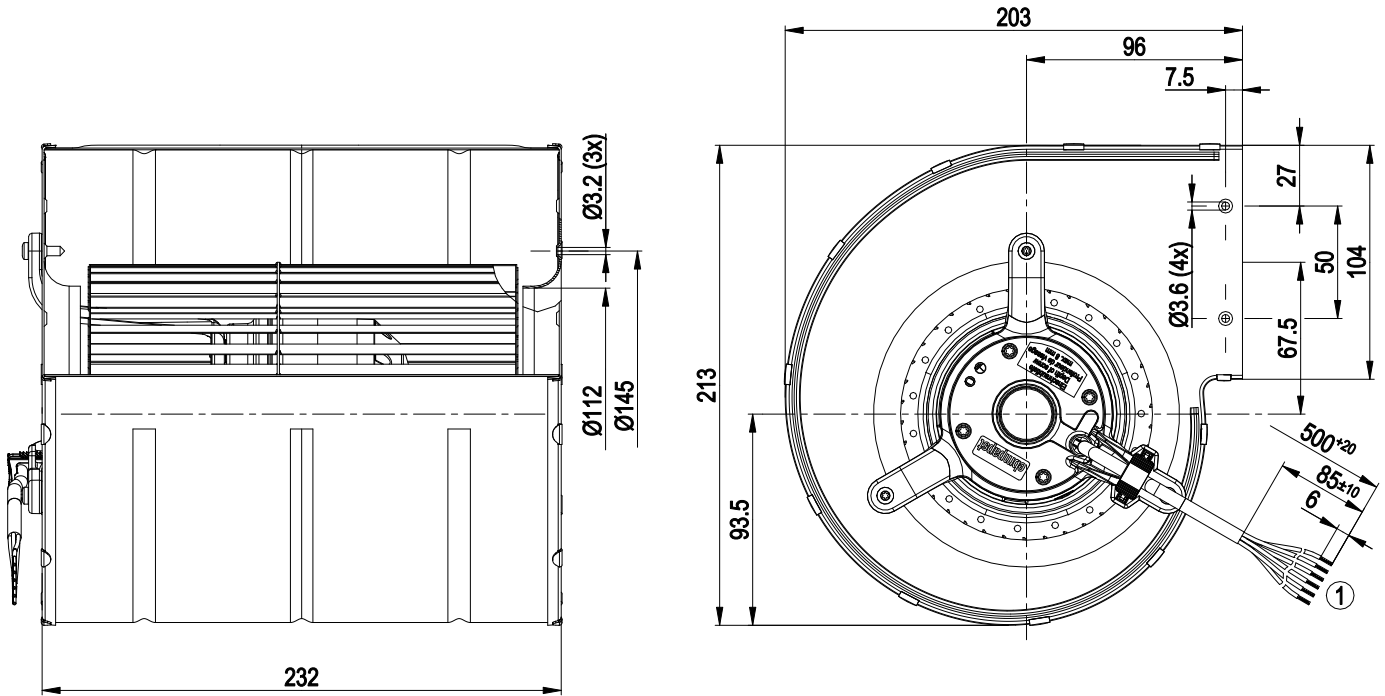

1 Connection line silicone 6G 0.5 mm², 6x lead tips crimped

Connection screen

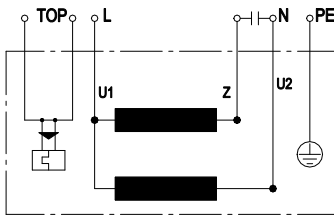

U1	Blue	Z	brown	U2	black
PE	green/yellow	TOP	2 x grey		



AC centrifugal fan

forward curved, dual inlet
with housing (without flange)

Charts: Air flow 50 Hz

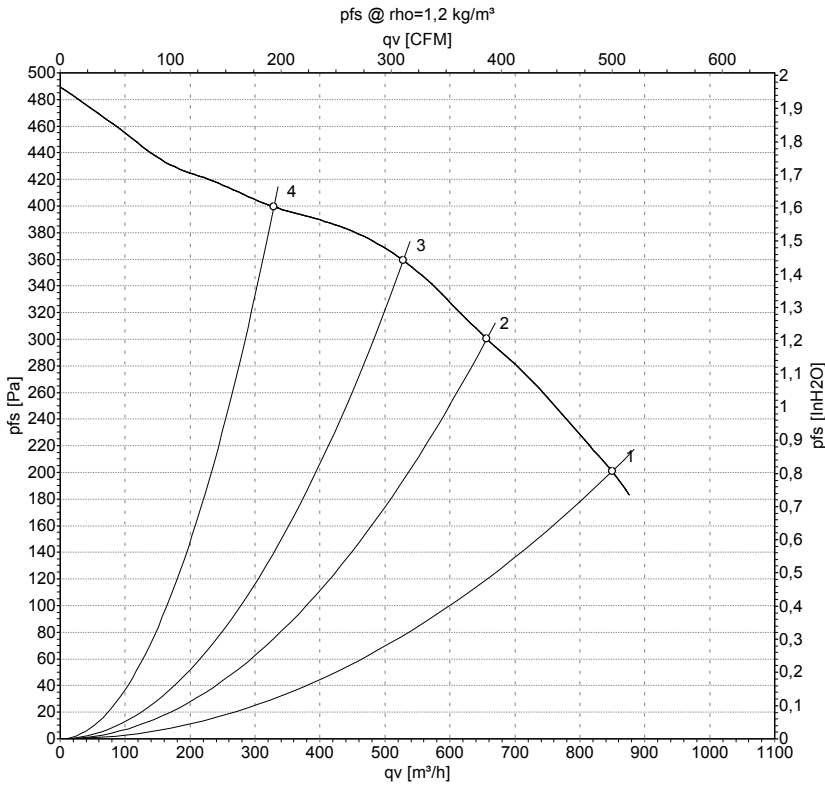

Measurement: LU-150660-1

Air performance measured as per ISO 5801 Installation category A. For detailed information on the measuring set-up, please contact ebm-papst. Suction-side noise levels: LwA measured as per ISO 13347 / LpA measured with 1m distance to fan axis. The values given are valid under the measuring conditions mentioned above and may vary according to the actual installation situation. With any deviation from the standard set-up, the specific values have to be checked and reviewed with the unit installed.

Measured values

	U	f	n	P _e	I	q _v	P _{fs}	q _v	P _{fs}
	V	Hz	min ⁻¹	W	A	m³/h	Pa	cfm	inH2O
1	230	50	2200	230	1.05	850	200	500	0.80
2	230	50	2425	188	0.82	655	300	385	1.20
3	230	50	2565	164	0.71	530	360	310	1.45
4	230	50	2670	141	0.62	330	400	195	1.61

U = Supply voltage · f = Frequency · n = Speed (rpm) · P_e = Power input · I = Current draw · q_v = Air flow · P_{fs} = Pressure increase



AC centrifugal fan

forward curved, dual inlet
with housing (without flange)

Charts: Air flow 60 Hz

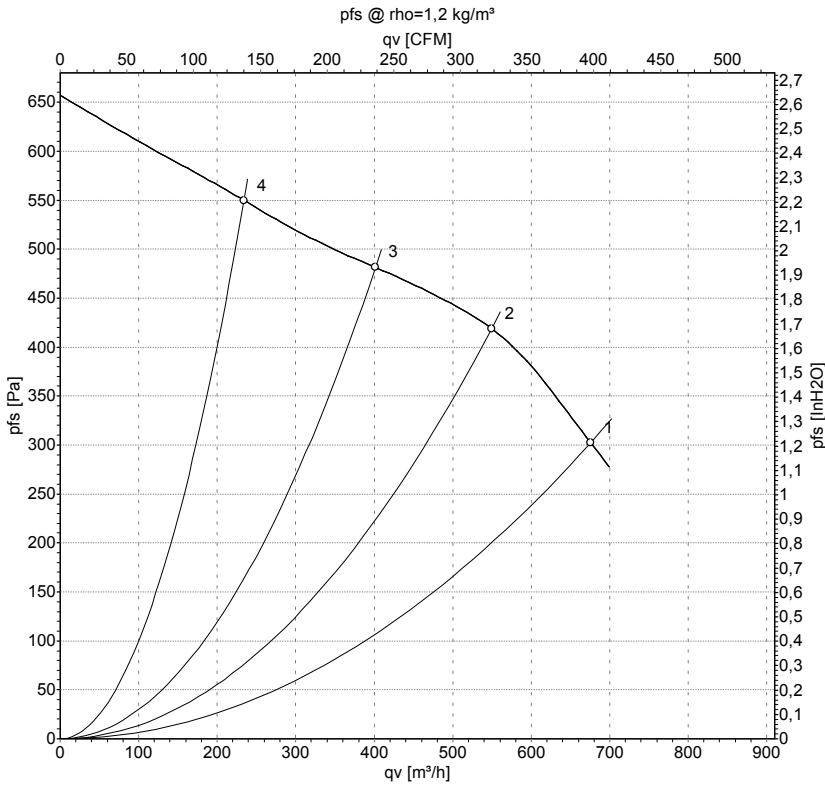

Measurement: LU-20679-1

Air performance measured as per ISO 5801 Installation category A. For detailed information on the measuring set-up, please contact ebmpapst. Suction-side noise levels: LwA measured as per ISO 13347 / LpA measured with 1m distance to fan axis. The values given are valid under the measuring conditions mentioned above and may vary according to the actual installation situation. With any deviation from the standard set-up, the specific values have to be checked and reviewed with the unit installed.

Measured values

	U	f	n	P _e	I	q _v	p _{fs}	q _v	p _{fs}
	V	Hz	min ⁻¹	W	A	m³/h	Pa	cfm	inH2O
1	230	60	2500	255	1.12	675	300	400	1.20
2	230	60	2815	231	1.00	550	420	325	1.69
3	230	60	3000	209	0.91	400	480	235	1.93
4	230	60	3145	188	0.82	235	550	140	2.21

U = Supply voltage · f = Frequency · n = Speed (rpm) · P_e = Power input · I = Current draw · q_v = Air flow · p_{fs} = Pressure increase

