

AC centrifugal fan

forward curved, dual inlet

with housing (flange)

D2E133-DM17-98 ebmpapst Datasheet

sales@fansco.com

www.fansco.com

Nominal data

Type	D2E133-DM17-98		
Motor	M2E068-DF		
Phase		1~	1~
Nominal voltage	VAC	230	230
Frequency	Hz	50	60
Type of data definition		fa	fa
Valid for approval / standard		CE	CE
Speed	min ⁻¹	1000	950
Power input	W	120	125
Current draw	A	0.53	0.55
Motor capacitor	µF	2.5	2.5
Capacitor voltage	VDB	400	400
Capacitor standard		P2 (CE)	P2 (CE)
Min. back pressure	Pa	0	0
Min. ambient temperature	°C	-25	-25
Max. ambient temperature	°C	70	65

ml = Max. load · me = Max. efficiency · fa = Running at free air · cs = Customer specs · cu = Customer unit
Subject to alterations



AC centrifugal fan

forward curved, dual inlet
with housing (flange)

Technical features

Mass	4.4 kg
Size	133 mm
Material of impeller	Sheet steel, galvanised
Housing material	Sheet steel, galvanised
Material of support structure	Sheet steel, galvanised
Direction of rotation	Clockwise, seen on rotor
Type of protection	IP 44; Depending on installation and position
Insulation class	"F"
Humidity class	F0
Max. permissible ambient motor temp. (transp./ storage)	+ 80 °C
Min. permissible ambient motor temp. (transp./storage)	- 40 °C
Mounting position	Any
Condensate discharge holes	None
Operation mode	S1
Motor bearing	Ball bearing
Speed steps	3
Touch current acc. IEC 60990 (measuring network Fig. 4, TN system)	< 0.75 mA
Electrical leads	Capacitor mounted
Motor protection	Thermal overload protector (TOP) wired internally
Cable exit	Variable
Protection class	I (if protective earth is connected by customer)
Product conforming to standard	EN 60335-1; CE



AC centrifugal fan

forward curved, dual inlet
with housing (flange)

Product drawing

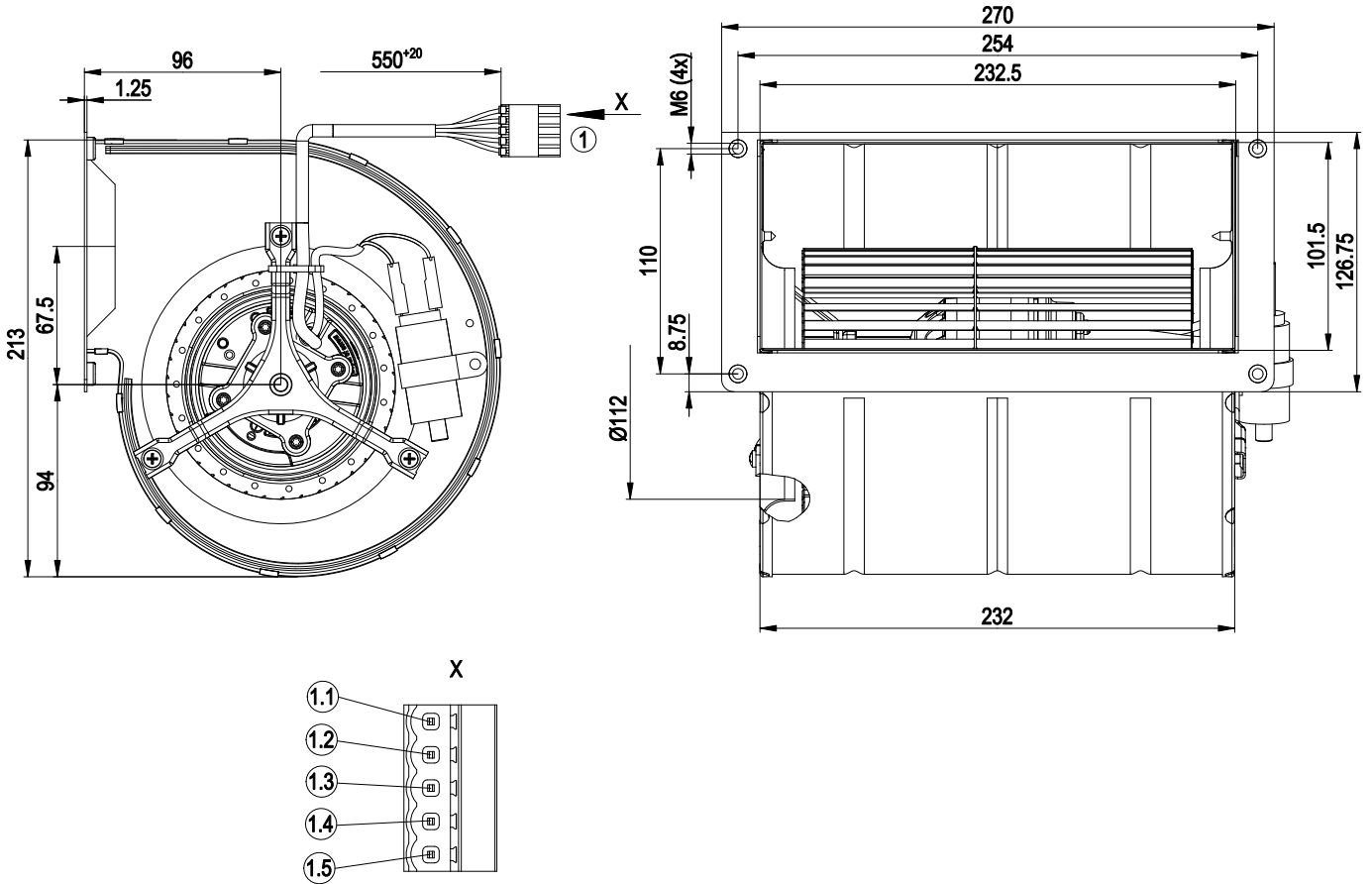

1	Connection line halogen- and silicone-free 5x 0.5 mm ² , connector housing 5-pin Weidmüller 170940, 5x crimped core-end sleeves
1.1	green/yellow
1.2	blue
1.3	white
1.4	grey
1.5	black



AC centrifugal fan

forward curved, dual inlet
with housing (flange)

Connection screen

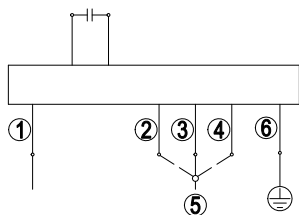

Note: Fast speed (step III); slow speed (step I)

1	blue (N)
2	Step I black 1 / white
3	Step II black 2 / grey
4	Step III black 3 / black
5	L1
6	PE (green/yellow)



AC centrifugal fan

forward curved, dual inlet
with housing (flange)

Charts: Air flow 50 Hz

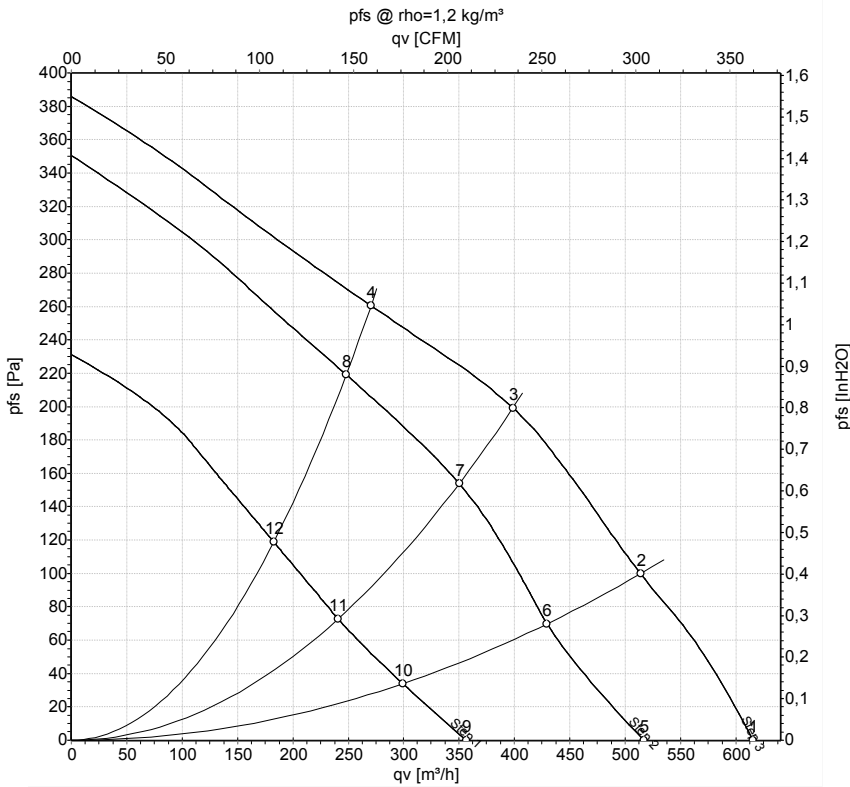

Measurement: LU-38045
Measurement: LU-38046
Measurement: LU-38048

Air performance measured as per ISO 5801 Installation category A. For detailed information on the measuring set-up, please contact ebm-papst. Suction-side noise levels: LwA measured as per ISO 13347 / LpA measured with 1m distance to fan axis. The values given are valid under the measuring conditions mentioned above and may vary according to the actual installation situation. With any deviation from the standard set-up, the specific values have to be checked and reviewed with the unit installed.

Measured values

	Stage	U	f	n	P _e	I	qv	P _{fs}
		V	Hz	min ⁻¹	W	A	m ³ /h	Pa
1	3	230	50	1000	120	0.53	615	0
2	3	230	50	1540	110	0.48	515	100
3	3	230	50	2015	99	0.43	400	200
4	3	230	50	2260	89	0.39	270	260
5	2	230	50	850	98	0.43	515	0
6	2	230	50	1305	94	0.41	430	69
7	2	230	50	1770	85	0.38	350	156
8	2	230	50	2075	77	0.35	250	219
9	1	230	50	585	74	0.33	355	0
10	1	230	50	890	72	0.33	300	33
11	1	230	50	1220	70	0.32	240	73
12	1	230	50	1535	66	0.31	185	119

U = Supply voltage · f = Frequency · n = Speed · P_e = Power input · I = Current draw · qv = Air flow · p_{fs} = Pressure increase



AC centrifugal fan

forward curved, dual inlet
with housing (flange)

Charts: Air flow 60 Hz

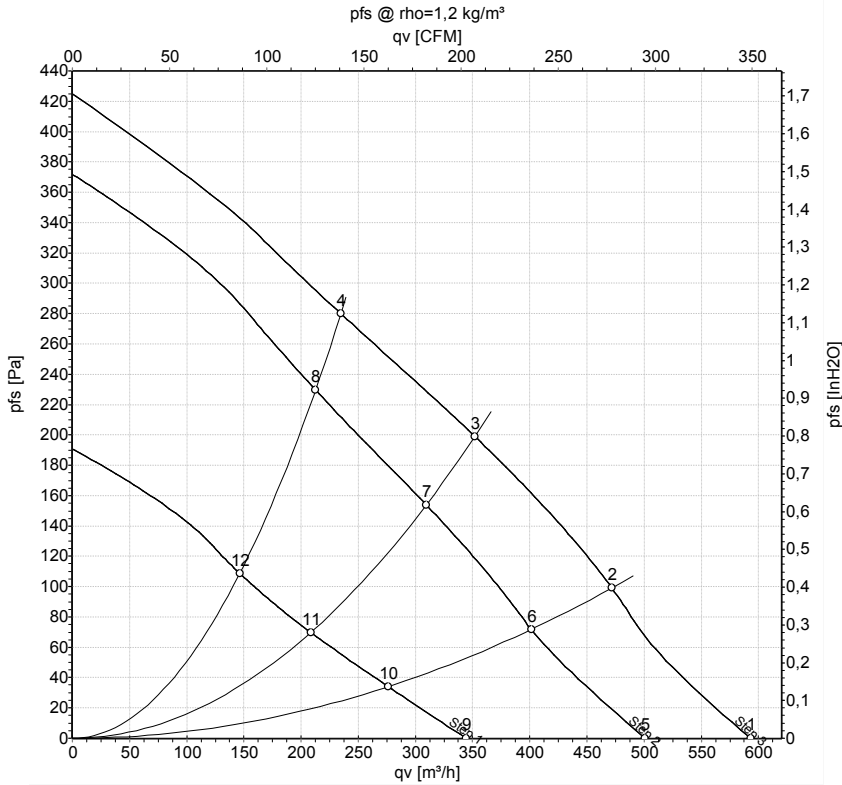

Measurement: LU-38049
Measurement: LU-38050
Measurement: LU-38051

Air performance measured as per ISO 5801 Installation category A. For detailed information on the measuring set-up, please contact ebmpapst. Suction-side noise levels: LwA measured as per ISO 13347 / LpA measured with 1m distance to fan axis. The values given are valid under the measuring conditions mentioned above and may vary according to the actual installation situation. With any deviation from the standard set-up, the specific values have to be checked and reviewed with the unit installed.

Measured values

	Stage	U	f	n	P _e	I	qv	P _{fs}
		V	Hz	min ⁻¹	W	A	m ³ /h	Pa
1	3	230	60	950	125	0.55	595	0
2	3	230	60	1490	120	0.52	470	100
3	3	230	60	2015	117	0.51	350	200
4	3	230	60	2330	112	0.49	235	280
5	2	230	60	810	101	0.45	500	0
6	2	230	60	1265	98	0.44	400	71
7	2	230	60	1775	94	0.43	310	154
8	2	230	60	2115	90	0.42	215	230
9	1	230	60	540	72	0.34	345	0
10	1	230	60	860	71	0.34	275	33
11	1	230	60	1170	70	0.34	210	70
12	1	230	60	1445	68	0.33	145	107

U = Supply voltage · f = Frequency · n = Speed · P_e = Power input · I = Current draw · qv = Air flow · p_{fs} = Pressure increase

