

D2E133-AM47-C3

# AC centrifugal fan

forward-curved, dual-intake

with housing (flange)



D2E133-AM47-C3 ebmpapst Datasheet

sales@fansco.com

www.fansco.com

## Nominal data

Type	D2E133-AM47-C3		
Motor	M2E068-DF		
Phase		1~	1~
Nominal voltage	VAC	230	230
Frequency	Hz	50	60
Method of obtaining data		fa	ml
Valid for approval/standard		CE	CE
Speed (rpm)	min <sup>-1</sup>	1500	1800
Power consumption	W	190	200
Current draw	A	0.84	0.88
Capacitor	µF	3	3
Capacitor voltage	VDB	450	450
Min. back pressure	Pa	0	100
Min. back pressure	in. wg	0	0.4
Min. ambient temperature	°C	-25	-25
Max. ambient temperature	°C	55	45
Starting current	A	0.9	

ml = Max. load · me = Max. efficiency · fa = Free air · cs = Customer specification · ce = Customer equipment  
Subject to change



# AC centrifugal fan

forward-curved, dual-intake

with housing (flange)

## Technical description

<b>Weight</b>	3.7 kg
<b>Size</b>	133 mm
<b>Motor size</b>	68
<b>Rotor surface</b>	Unpainted
<b>Impeller material</b>	Sheet steel, galvanized
<b>Housing material</b>	Sheet steel, galvanized
<b>Motor suspension</b>	Motor mounted with brackets on one side
<b>Direction of rotation</b>	Clockwise, viewed toward rotor
<b>Degree of protection</b>	IP44; installation- and position-dependent
<b>Insulation class</b>	"F"
<b>Moisture (F) / Environmental (H) protection class</b>	H0+; F1-1
<b>Max. permitted ambient temp. for motor (transport/storage)</b>	+ 80 °C
<b>Min. permitted ambient temp. for motor (transport/storage)</b>	- 40 °C
<b>Installation position</b>	Any
<b>Condensation drainage holes</b>	None
<b>Mode</b>	S1
<b>Motor bearing</b>	Ball bearing
<b>Touch current according to IEC 60990 (measuring circuit Fig. 4, TN system)</b>	< 0.75 mA
<b>Motor protection</b>	Thermal overload protector (TOP) internally connected
<b>With cable</b>	Axial
<b>Protection class</b>	I (with customer connection of protective earth)
<b>Conformity with standards</b>	EN 60335-1; CE
<b>Approval</b>	UL 1004-1; CSA C22.2 No. 100; EAC



# AC centrifugal fan

forward-curved, dual-intake  
with housing (flange)

## Product drawing

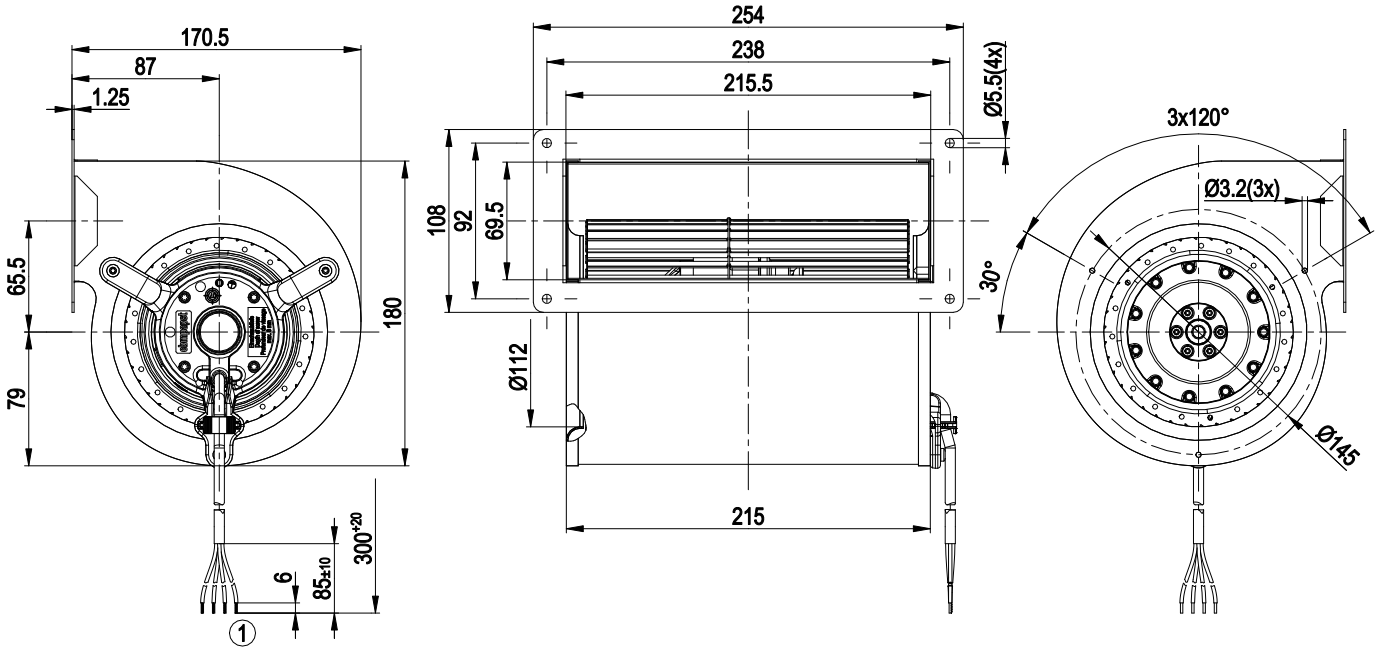

1 Cable PFA AWG20 (green/yellow AWG18), 4x crimped splices

## Connection diagram

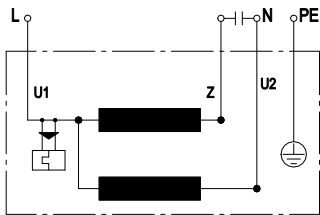

U1	blue	Z	brown	U2	black
PE	green/yellow				



# AC centrifugal fan

forward-curved, dual-intake  
with housing (flange)

## Curves: Air performance 50 Hz

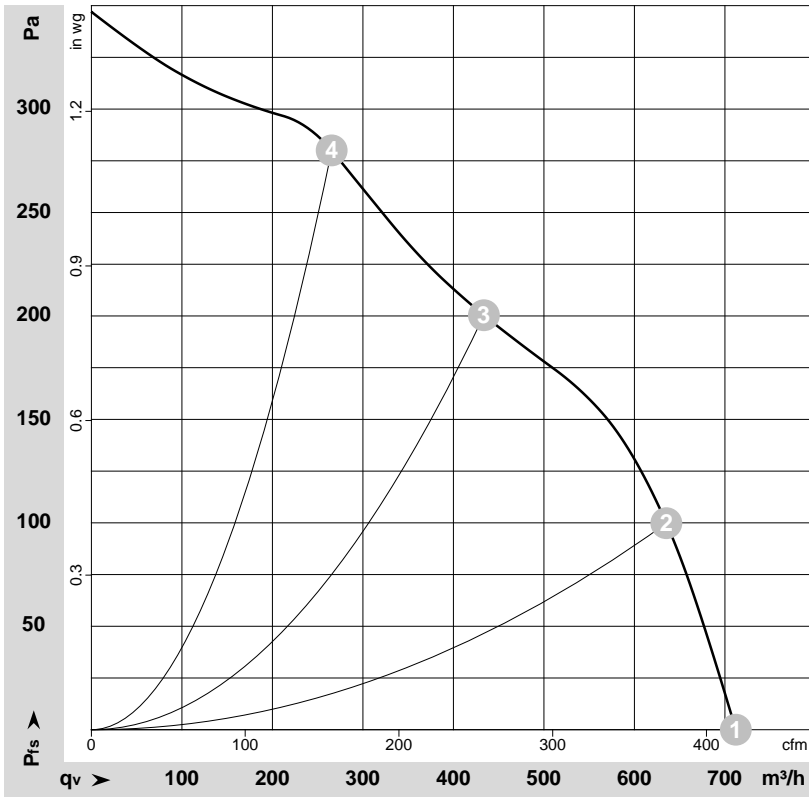

$\rho = 1.15 \text{ kg/m}^3 \pm 2 \%$

Measurement: LU-105263-1

Air performance measured according to ISO 5801 installation category A. For detailed information on the measurement setup, contact ebmpapst. Intake sound level: Sound power level according to ISO 13347 / sound pressure level measured at 1 m distance from fan axis. The values given are valid under the specified measuring conditions and may vary due to conditions of installation. For deviations from the standard configuration, the parameters have to be checked on the installed unit.

## Measured values

	U	f	n	P <sub>e</sub>	I	q <sub>v</sub>	p <sub>fs</sub>	q <sub>v</sub>	p <sub>fs</sub>
	V	Hz	min <sup>-1</sup>	W	A	m <sup>3</sup> /h	Pa	cfm	in. wg
1	230	50	1500	190	0.84	710	0	420	0.00
2	230	50	1900	164	0.71	635	100	375	0.40
3	230	50	2355	137	0.60	435	200	255	0.80
4	230	50	2615	114	0.50	265	280	155	1.12

U = Voltage · f = Frequency · n = Speed (rpm) · P<sub>e</sub> = Power consumption · I = Current draw · q<sub>v</sub> = Air flow · p<sub>fs</sub> = Pressure increase



# AC centrifugal fan

forward-curved, dual-intake  
with housing (flange)

## Curves: Air performance 60 Hz

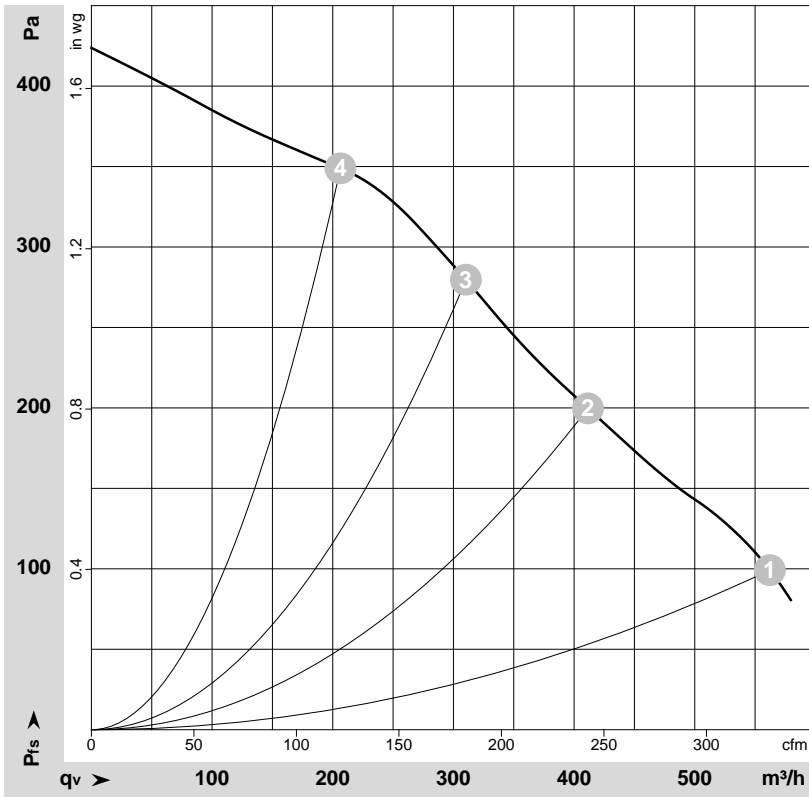

$\rho = 1.15 \text{ kg/m}^3 \pm 2 \%$

Measurement: LU-105265-1

Air performance measured according to ISO 5801 installation category A. For detailed information on the measurement setup, contact ebm-papst. Intake sound level: Sound power level according to ISO 13347 / sound pressure level measured at 1 m distance from fan axis. The values given are valid under the specified measuring conditions and may vary due to conditions of installation. For deviations from the standard configuration, the parameters have to be checked on the installed unit.

## Measured values

	U	f	n	P <sub>e</sub>	I	q <sub>v</sub>	p <sub>fs</sub>	q <sub>v</sub>	p <sub>fs</sub>
	V	Hz	min <sup>-1</sup>	W	A	m <sup>3</sup> /h	Pa	cfm	in. wg
1	230	60	1800	200	0.88	560	100	330	0.40
2	230	60	2345	180	0.78	410	200	240	0.80
3	230	60	2655	171	0.74	310	280	180	1.12
4	230	60	2910	161	0.70	205	350	120	1.41

U = Voltage · f = Frequency · n = Speed (rpm) · P<sub>e</sub> = Power consumption · I = Current draw · q<sub>v</sub> = Air flow · p<sub>fs</sub> = Pressure increase

