

# AC centrifugal fan

forward curved, dual inlet  
with housing and angle bracket

D2D160-CE02-12 ebmpapst Datasheet  
sales@fansco.com  
www.fansco.com

Limited partnership · Headquarters Mulfingen  
County court Stuttgart · HRA 590344

General partner Elektrobau Mulfingen GmbH · Headquarters Mulfingen  
County court Stuttgart · HRB 590142

## Nominal data

Type	D2D160-CE02-12				
Motor	M2D074-LA				
Phase		3~	3~	3~	3~
Nominal voltage	VAC	230	230	400	400
Connection		$\Delta$	$\Delta$	Y	Y
Frequency	Hz	50	60	50	60
Type of data definition		ml	ml	ml	ml
Valid for approval / standard		CE	CE	CE	CE
Speed (rpm)	min <sup>-1</sup>	2700	2960	2700	2960
Power input	W	700	1055	700	1055
Current draw	A	1.9	2.82	1.1	1.63
Min. back pressure	Pa	460	560	460	560
Min. ambient temperature	°C	-25	-25	-25	-25
Max. ambient temperature	°C	90	50	90	50
Starting current	A	9.25	9.6	5.34	5.54

ml = Max. load · me = Max. efficiency · fa = Running at free air · cs = Customer specs · cu = Customer unit  
Subject to alterations

## Data according to ErP directive

		Actual	Request 2015		
01 Overall efficiency $\eta_{es}$	%	35.9	35.9	09 Power input $P_e$	kW 0.52
02 Measurement category		A		09 Air flow $q_v$	m <sup>3</sup> /h 1205
03 Efficiency category		Static		09 Pressure increase $p_{fs}$	Pa 551
04 Efficiency grade N		44	44	10 Speed (rpm) n	min <sup>-1</sup> 2795
05 Variable speed drive		No		11 Specific ratio*	1.01

Data definition with optimum efficiency.  
The ErP data is determined using a motor-impeller combination in a standardised measurement configuration.

\* Specific ratio =  $1 + p_g / 100\,000\text{ Pa}$

LU-154175



# AC centrifugal fan

forward curved, dual inlet  
with housing and angle bracket

## Technical features

<b>Mass</b>	11.3 kg
<b>Size</b>	160 mm
<b>Surface of rotor</b>	Coated in black
<b>Material of impeller</b>	Sheet steel, galvanised
<b>Housing material</b>	Sheet steel, galvanised
<b>Material of guard grille</b>	Steel, coated in grey plastic (RAL 9006)
<b>Motor suspension</b>	Motor mounted anti-vibration on both sides
<b>Direction of rotation</b>	Counter-clockwise, seen on rotor
<b>Type of protection</b>	IP 00
<b>Insulation class</b>	"F"
<b>Humidity (F)/environmental protection class (H)</b>	H0+
<b>Max. permissible ambient motor temp. (transp./ storage)</b>	+ 80 °C
<b>Min. permissible ambient motor temp. (transp./storage)</b>	- 40 °C
<b>Mounting position</b>	Any
<b>Condensate discharge holes</b>	None, open rotor
<b>Operation mode</b>	S1
<b>Motor bearing</b>	Ball bearing
<b>Touch current acc. IEC 60990 (measuring network Fig. 4, TN system)</b>	< 0.75 mA
<b>Electrical leads</b>	With plug
<b>Motor protection</b>	Thermal overload protector (TOP) brought out, basic insulation
<b>Cable exit</b>	Axial
<b>Protection class</b>	I (if protective earth is connected by customer)
<b>Product conforming to standard</b>	EN 60335-1; CE
<b>Approval</b>	CSA C22.2 No.100; CCC; UL 1004-1



# AC centrifugal fan

forward curved, dual inlet  
with housing and angle bracket

## Product drawing

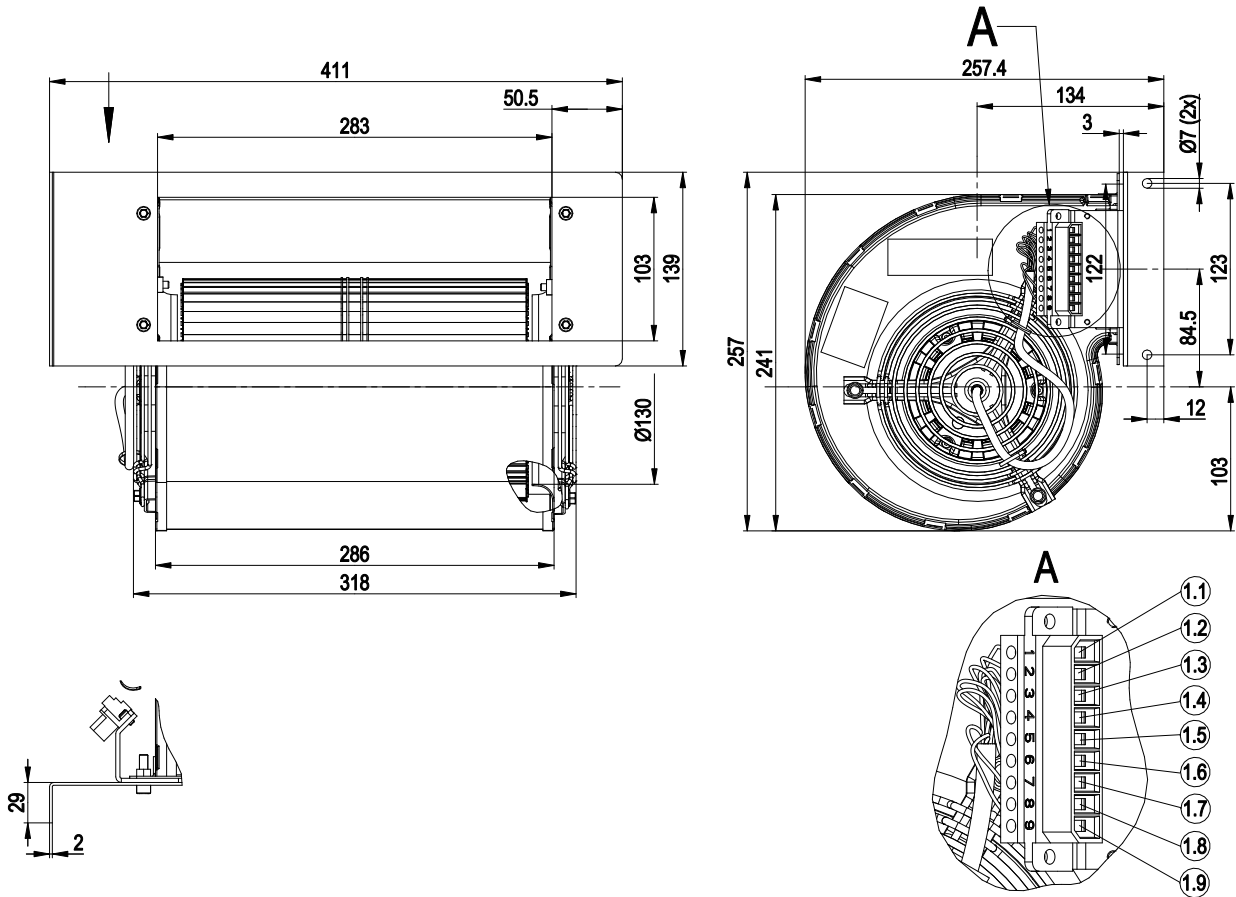

1	9-pole Weidmüller strip 1612160000
1.1	black
1.2	blue
1.3	brown
1.4	grey (TOP)
1.5	FE (green/yellow)
1.6	grey (TOP)
1.7	green
1.8	white
1.9	yellow



# AC centrifugal fan

forward curved, dual inlet  
with housing and angle bracket

## Connection screen

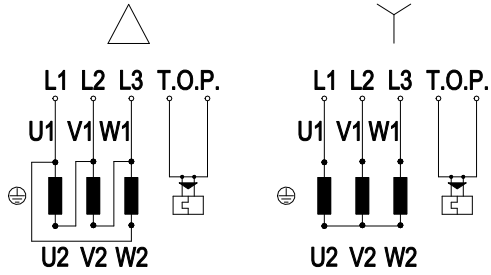

Note: Direction of rotation changes when two phases are reversed

$\Delta$	Delta-connection	Y	Star connection	L1	black
L2	blue	L3	brown	U1	black
V1	blue	W1	brown	U2	green
V2	white	W2	yellow	TOP	grey



# AC centrifugal fan

forward curved, dual inlet  
with housing and angle bracket

## Charts: Air flow 50 Hz

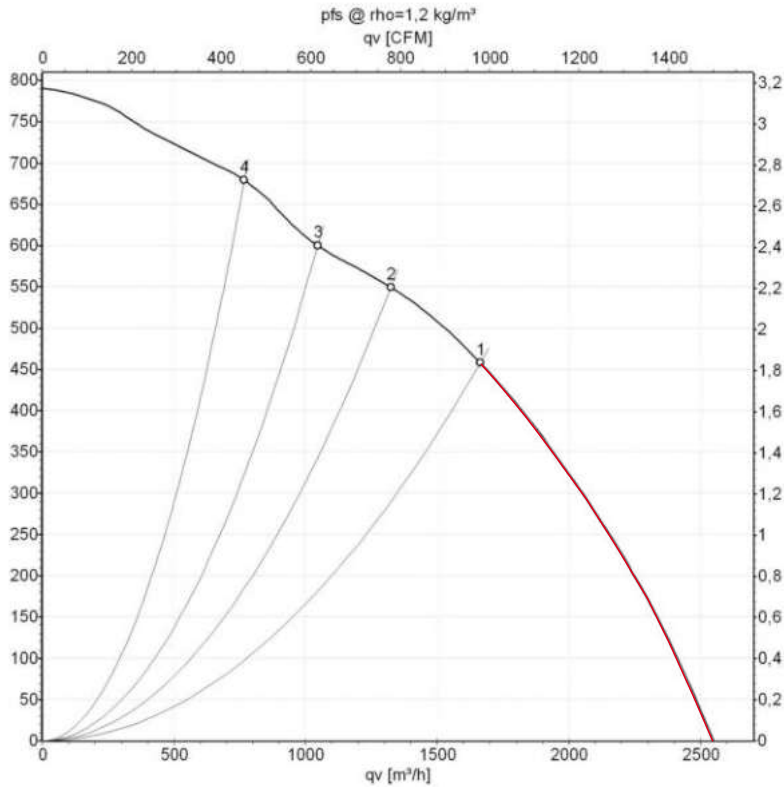

Air performance measured as per ISO 5801 Installation category A. For detailed information on the measuring set-up, please contact ebmpapst. Suction-side noise levels: LwA measured as per ISO 13347 / LpA measured with 1m distance to fan axis. The values given are valid under the measuring conditions mentioned above and may vary according to the actual installation situation. With any deviation from the standard set-up, the specific values have to be checked and reviewed with the unit installed.

## Measured values

	Conn.	U	f	n	P <sub>e</sub>	I	q <sub>v</sub>	P <sub>fs</sub>	q <sub>v</sub>	P <sub>fs</sub>
		V	Hz	min <sup>-1</sup>	W	A	m <sup>3</sup> /h	Pa	cfm	inH <sub>2</sub> O
1	Y	400	50	2700	700	1.10	1660	460	975	1.85
2	Y	400	50	2775	562	0.97	1320	550	775	2.21
3	Y	400	50	2815	482	0.87	1045	600	615	2.41
4	Y	400	50	2840	428	0.81	765	680	450	2.73

Conn. = Connection · U = Supply voltage · f = Frequency · n = Speed (rpm) · P<sub>e</sub> = Power input · I = Current draw · q<sub>v</sub> = Air flow · p<sub>e</sub> = Pressure increase



# AC centrifugal fan

forward curved, dual inlet  
with housing and angle bracket

## Charts: Air flow 60 Hz

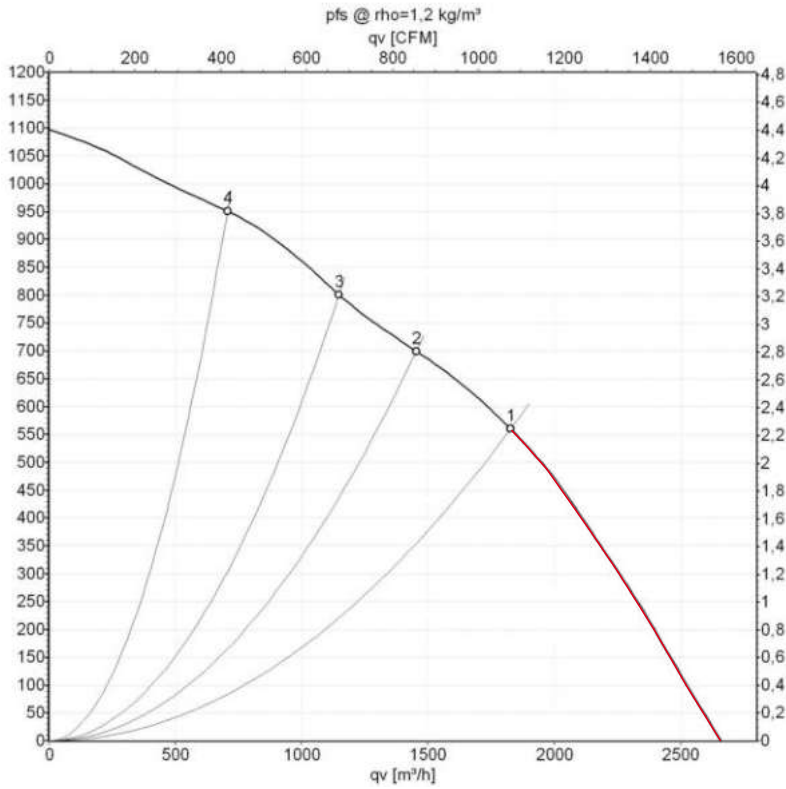

Air performance measured as per ISO 5801 Installation category A. For detailed information on the measuring set-up, please contact ebmpapst. Suction-side noise levels: LwA measured as per ISO 13347 / LpA measured with 1m distance to fan axis. The values given are valid under the measuring conditions mentioned above and may vary according to the actual installation situation. With any deviation from the standard set-up, the specific values have to be checked and reviewed with the unit installed.

## Measured values

	Conn.	U	f	n	P <sub>e</sub>	I	q <sub>v</sub>	P <sub>fs</sub>	q <sub>v</sub>	P <sub>fs</sub>
		V	Hz	min <sup>-1</sup>	W	A	m <sup>3</sup> /h	Pa	cfm	inH2O
1	Y	400	60	2960	1055	1.63	1830	560	1075	2.25
2	Y	400	60	3120	871	1.35	1465	700	860	2.81
3	Y	400	60	3210	737	1.16	1145	800	675	3.21
4	Y	400	60	3300	592	0.95	710	950	420	3.81

Conn. = Connection · U = Supply voltage · f = Frequency · n = Speed (rpm) · P<sub>e</sub> = Power input · I = Current draw · q<sub>v</sub> = Air flow · p<sub>e</sub> = Pressure increase

