

AC centrifugal fan

forward-curved, dual-intake

with housing (flange), for rail applications

D2D146-AA12-03 ebmpapst Datasheet

sales@fansco.com

www.fansco.com

Nominal data

Type	D2D146-AA12-03				
Motor	M2D068-EC				
Phase		3~	3~	3~	3~
Nominal voltage	VAC	400	400	400	400
Wiring		Δ	Y	Δ	Y
Frequency	Hz	50	50	60	60
Method of obtaining data		ml	ml	ml	ml
Valid for approval/standard		CE	CE	CE	CE
Speed (rpm)	min ⁻¹	2300	1500	2500	1500
Power consumption	W	265	150	305	150
Current draw	A	0.41	0.23	0.47	0.24
Min. back pressure	Pa	300	130	360	125
Min. back pressure	in. wg	1.2	0.52	1.45	0.5
Min. ambient temperature	°C	-40	-40	-40	-40
Max. ambient temperature	°C	60	60	45	45
Starting current	A	0.85	0.3	0.9	0.3

ml = Max. load · me = Max. efficiency · fa = Free air · cs = Customer specification · ce = Customer equipment
Subject to change



AC centrifugal fan

forward-curved, dual-intake

with housing (flange), for rail applications

Technical description

Weight	4.43 kg
Size	146 mm
Motor size	68
Rotor surface	Painted black
Impeller material	Sheet steel, galvanized
Housing material	Sheet steel, galvanized
Direction of rotation	Counterclockwise, viewed toward rotor
Degree of protection	IP44
Insulation class	"F"
Moisture (F) / Environmental (H) protection class	H1+
Max. permitted ambient temp. for motor (transport/storage)	+80 °C
Min. permitted ambient temp. for motor (transport/storage)	-40 °C
Installation position	Shaft horizontal or rotor on bottom; rotor on top on request
Condensation drainage holes	On rotor side
Mode	S1
Motor bearing	Hybrid bearing
Touch current according to IEC 60990 (measuring circuit Fig. 4, TN system)	< 0.75 mA
Motor protection	Thermal overload protector (TOP) with basic insulation
Protection class assignment	I; If a protective earth is connected by the customer This component for installation may have several local protection classes. This information relates to this component's basic design. The final protection class is based on the component's intended installation and connection.
Conformity with standards	EN 50155: 2008; EN 61373, Cat. 1B: 2010; EN 45545-2, HL3: 2013 + A1:2015
Approval	EAC
Comment	Prerequisite for operation is a Class 1 vehicle electrical system architecture according to EN 50533



AC centrifugal fan

forward-curved, dual-intake

with housing (flange), for rail applications

Product drawing

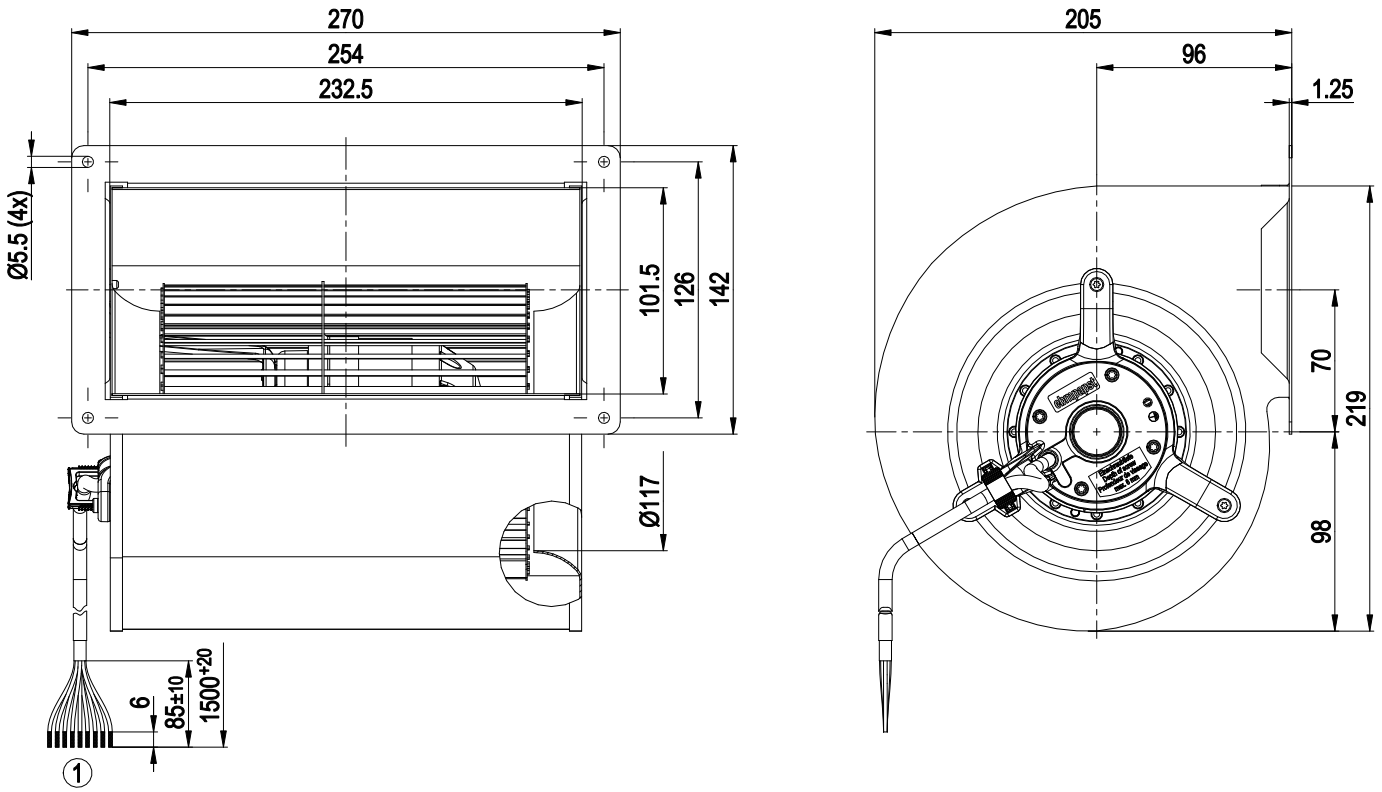

1	Cable, halogen-free, railway application EN 45545, 9G 0.5 mm ²
	9x splice



AC centrifugal fan

forward-curved, dual-intake
with housing (flange), for rail applications

Connection diagram

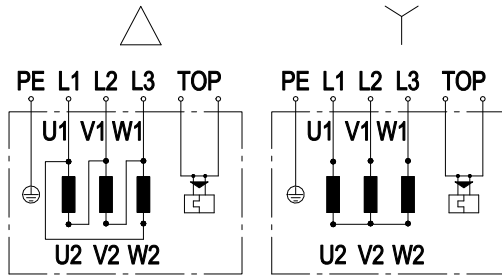

Note: Change of rotation direction by reversing two phases

Δ	Delta connection	Y	Star connection	L1	black
L2	blue	L3	brown	U1	black
V1	blue	W1	brown	U2	green
V2	white	W2	yellow	TOP	2x gray
PE	green/yellow				



AC centrifugal fan

forward-curved, dual-intake

with housing (flange), for rail applications

Curves: Air performance 50 Hz

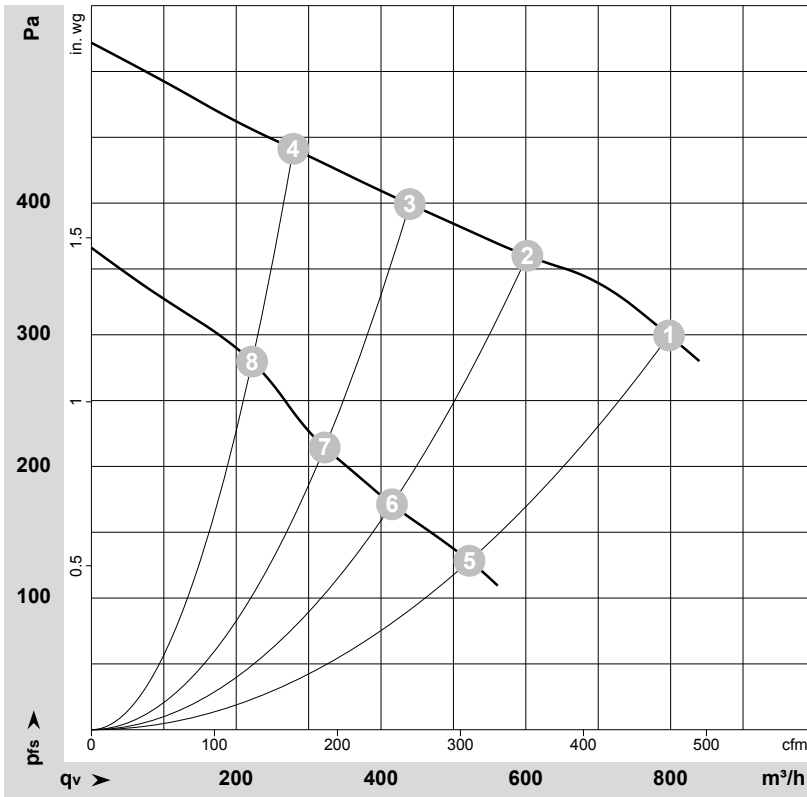

$\rho = 1.15 \text{ kg/m}^3 \pm 2 \%$

Measurement: LU-193302-1
Measurement: LU-193272-1

Air performance measured according to ISO 5801 installation category A. For detailed information on the measurement setup, contact ebmpapst. Intake sound level: Sound power level according to ISO 13347 / sound pressure level measured at 1 m distance from fan axis. The values given are valid under the specified measuring conditions and may vary due to conditions of installation. For deviations from the standard configuration, the parameters have to be checked on the installed unit.

Measured values

	Wired	U	f	n	P _e	I	LpA _{in}	LwA _{in}	q _v	P _{fs}	q _v	P _{fs}
		V	Hz	min ⁻¹	W	A	dB(A)	dB(A)	m ³ /h	Pa	cfm	in. wg
1	Δ	400	50	2300	265	0.41	61	72	800	300	470	1.20
2	Δ	400	50	2495	212	0.34	62	72	600	360	355	1.45
3	Δ	400	50	2610	178	0.29	63	73	440	400	260	1.61
4	Δ	400	50	2720	138	0.24	64	75	280	440	165	1.77
5	Y	400	50	1500	150	0.23	50	61	520	130	305	0.52
6	Y	400	50	1735	136	0.21	52	63	415	171	245	0.69
7	Y	400	50	1920	124	0.19	55	66	320	214	190	0.86
8	Y	400	50	2180	104	0.16	59	70	220	280	130	1.12

Wired = Wiring · U = Voltage · f = Frequency · n = Speed (rpm) · P_e = Power consumption · I = Current draw · LpA_{in} = Sound pressure level intake side · LwA_{in} = Sound power level intake side
q_v = Air flow · P_{fs} = Pressure increase



AC centrifugal fan

forward-curved, dual-intake

with housing (flange), for rail applications

Curves: Air performance 60 Hz

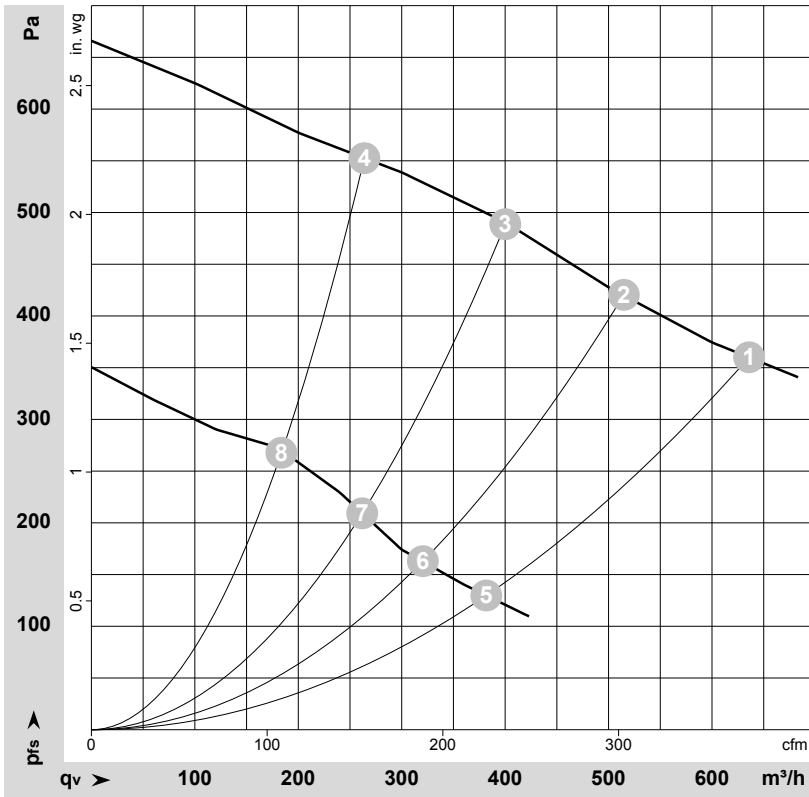

$\rho = 1.15 \text{ kg/m}^3 \pm 2 \%$

Measurement: LU-193304-1
Measurement: LU-193303-1

Air performance measured according to ISO 5801 installation category A. For detailed information on the measurement setup, contact ebm-papst. Intake sound level: Sound power level according to ISO 13347 / sound pressure level measured at 1 m distance from fan axis. The values given are valid under the specified measuring conditions and may vary due to conditions of installation. For deviations from the standard configuration, the parameters have to be checked on the installed unit.

Measured values

	Wired	U	f	n	P _e	I	LpA _{in}	LwA _{in}	q _v	P _{fs}	q _v	P _{fs}
		V	Hz	min ⁻¹	W	A	dB(A)	dB(A)	m ³ /h	Pa	cfm	in. wg
1	Δ	400	60	2500	305	0.47	62	73	635	360	375	1.45
2	Δ	400	60	2690	270	0.42	63	74	515	420	305	1.69
3	Δ	400	60	2875	235	0.36	65	76	400	490	235	1.97
4	Δ	400	60	3040	196	0.31	67	78	265	550	155	2.21
5	Y	400	60	1500	150	0.24	49	60	380	130	225	0.52
6	Y	400	60	1690	146	0.22	52	63	320	163	190	0.65
7	Y	400	60	1890	138	0.21	55	66	260	209	155	0.84
8	Y	400	60	2110	129	0.20	58	69	185	270	110	1.08

Wired = Wiring · U = Voltage · f = Frequency · n = Speed (rpm) · P_e = Power consumption · I = Current draw · LpA_{in} = Sound pressure level intake side · LwA_{in} = Sound power level intake side
q_v = Air flow · P_{fs} = Pressure increase

