

AC centrifugal fan

forward-curved, dual-intake

with housing (flange)

Nominal data

Type	D2D146-AA02-13	
Motor	M2D068-EC	
Phase		3~
Nominal voltage	VAC	400
Wiring		Y
Frequency	Hz	50
Method of obtaining data		ml
Valid for approval/standard		-
Speed (rpm)	min ⁻¹	2250
Power consumption	W	290
Current draw	A	0.47
Min. back pressure	Pa	275
Min. back pressure	inH ₂ O	1.1
Min. ambient temperature	°C	-25
Max. ambient temperature	°C	60
Starting current	A	1.0

ml = Max. load · me = Max. efficiency · fa = Free air · cs = Customer specification · ce = Customer equipment
Subject to change

AC centrifugal fan

forward-curved, dual-intake
with housing (flange)

Technical description

Weight	4.4 kg
Fan size	146 mm
Rotor surface	Partly cast in aluminum
Impeller material	Sheet steel, hot-dip galvanized
Housing material	Sheet steel, hot-dip galvanized
Motor suspension	Motor mounted with brackets on one side
Direction of rotation	Counterclockwise, viewed toward rotor
Degree of protection	IP44
Insulation class	"F"
Moisture (F) / Environmental (H) protection class	F2-2
Max. permitted ambient temp. for motor (transport/storage)	+ 80 °C
Min. permitted ambient temp. for motor (transport/storage)	- 40 °C
Installation position	Shaft horizontal or rotor on bottom; rotor on top on request
Condensation drainage holes	On rotor side
Mode	S1
Motor bearing	Ball bearing
Touch current according to IEC 60990 (measuring circuit Fig. 4, TN system)	< 0.75 mA
Motor protection	Thermal overload protector (TOP) with basic insulation
With cable	Axial
Protection class	I (with customer connection of protective earth)
Conformity with standards	EN 60335-1
Approval	CCC



AC centrifugal fan

forward-curved, dual-intake
with housing (flange)

Product drawing

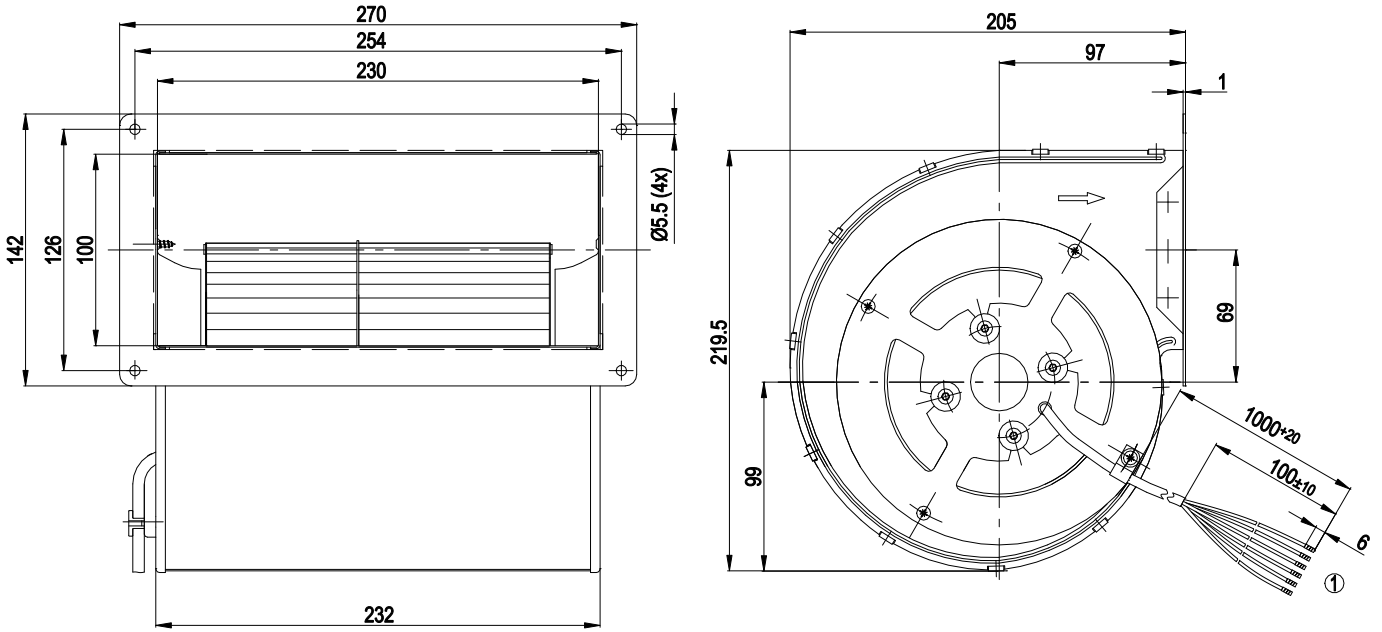

1 Cable halogen-silicone-free 0.5 mm², 6x crimped splices



AC centrifugal fan

forward-curved, dual-intake
with housing (flange)

Connection diagram

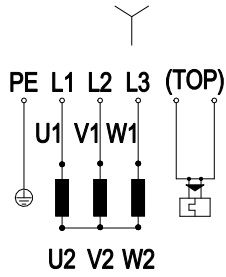

Y	Star connection	L1	black	L2	blue
L3	brown	U1	black	V1	blue
W1	brown	U2	green	V2	white
W2	yellow	TOP	2x gray	PE	green/yellow



AC centrifugal fan

forward-curved, dual-intake

with housing (flange)

Curves: Air performance 50 Hz

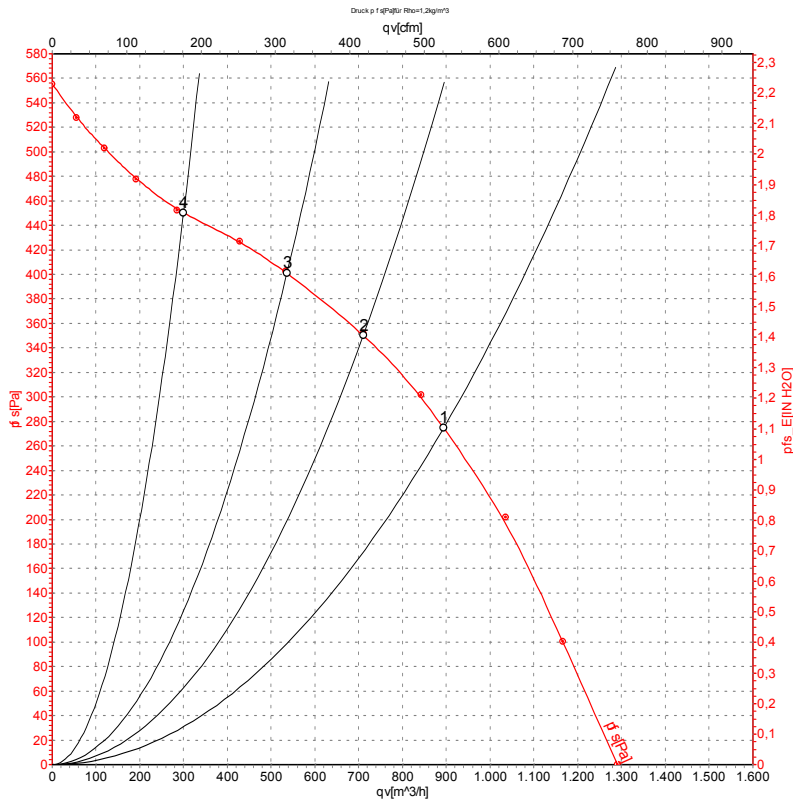

Measurement: LU-38467-1

Air performance measured according to ISO 5801 installation category A. For detailed information on the measurement setup, contact ebm-papst. Intake sound level: Sound power level according to ISO 13347 / sound pressure level measured at 1 m distance from fan axis. The values given are valid under the specified measuring conditions and may vary due to conditions of installation. For deviations from the standard configuration, the parameters have to be checked on the installed unit.

Measured values

	U	f	n	P _e	I	qv	p _{fs}	qv	p _{fs}
	V	Hz	min ⁻¹	W	A	m ³ /h	Pa	CFM	inH ₂ O
1	400	50	2250	290	0.47	895	275	525	1.10
2	400	50	2420	241	0.39	710	350	420	1.41
3	400	50	2540	201	0.34	535	400	315	1.61
4	400	50	2685	149	0.27	300	450	175	1.81

U = Power supply · f = Frequency · n = Speed (rpm) · P_e = Power consumption · I = Current draw · qv = Air flow · p_{fs} = Pressure increase

