

EC centrifugal fan

forward-curved, dual-intake

with housing (flange)

D1G146-LV03-06 ebmpapst Datasheet FansCo

sales@fansco.com

www.fansco.com

Nominal data

Type	D1G146-LV03-06	
Motor	M1G055-DF	
Phase		1~
Nominal voltage	VAC	230
Nominal voltage range	VAC	200 .. 240
Frequency	Hz	50/60
Method of obtaining data		ml
Speed (rpm)	min ⁻¹	1840
Power consumption	W	165
Current draw	A	1.20
Min. back pressure	Pa	115
Min. back pressure	in. wg	0.46
Min. ambient temperature	°C	-25
Max. ambient temperature	°C	50

ml = Max. load · me = Max. efficiency · fa = Free air · cs = Customer specification · ce = Customer equipment
Subject to change

Data according to Commission Regulation (EU) 327/2011 (EN 17166)

	Actual	Req. 2015				
01 Overall efficiency η_{es}	%	33.8	32.8	09 Power consumption P_{ed}	kW	0.16
02 Measurement category		A		09 Air flow q_v	m ³ /h	400
03 Efficiency category		Static		09 Pressure increase p_{fs}	Pa	448
04 Efficiency grade N		45	44	10 Speed (rpm) n	min ⁻¹	2885
05 Variable speed drive		Yes		11 Specific ratio*		1.00

Data obtained at optimum efficiency level.

* Specific ratio = $1 + p_s / 100\,000\text{ Pa}$

LU-209751

The efficiency values displayed for achieving conformity with the Ecodesign Regulation EU 327/2011 has been reached with defined air duct components (e.g. inlet rings).
The dimensions must be requested from ebm-papst. If other air conduction geometries are used on the installation side, the ebm-papst evaluation loses its validity/the conformity must be confirmed again.
The product does not fall within the scope of Regulation (EU) 2019/1781 due to the exception specified in Article 2 (2a) (motors completely integrated into a product).



D1G146-LV03-06

EC centrifugal fan

forward-curved, dual-intake

with housing (flange)

Technical description

Weight	2.467 kg
Size	146 mm
Motor size	55
Rotor surface	Thick-film passivated
Electronics housing material	PP plastic
Impeller material	Sheet steel, galvanized
Housing material	PP plastic
Motor suspension	Motor vibration-damped on both sides
Direction of rotation	Counterclockwise, viewed toward rotor
Degree of protection	IP20
Insulation class	"B"
Moisture (F) / Environmental (H) protection class	H0 - dry environment
Max. permitted ambient temp. for motor (transport/storage)	+ 80 °C
Min. permitted ambient temp. for motor (transport/storage)	- 40 °C
Installation position	Any
Condensation drainage holes	None, open rotor
Mode	S1
Motor bearing	Ball bearing
Technical features	<ul style="list-style-type: none">- Fault output (open collector)- Motor current limitation- Soft start- PWM control input- Control interface with SELV potential safely disconnected from the mains- Thermal overload protection for motor
Touch current according to IEC 60990 (measuring circuit Fig. 4, TN system)	<= 3.5 mA
Electrical hookup	Connector with cable
Motor protection	Thermal overload protector (TOP) internally connected
Protection class	Built-in component, protection class results from installation according to intended use
Conformity with standards	EN 60335-1; CE



ebmpapst

D1G146-LV03-06

EC centrifugal fan

forward-curved, dual-intake
with housing (flange)

Product drawing

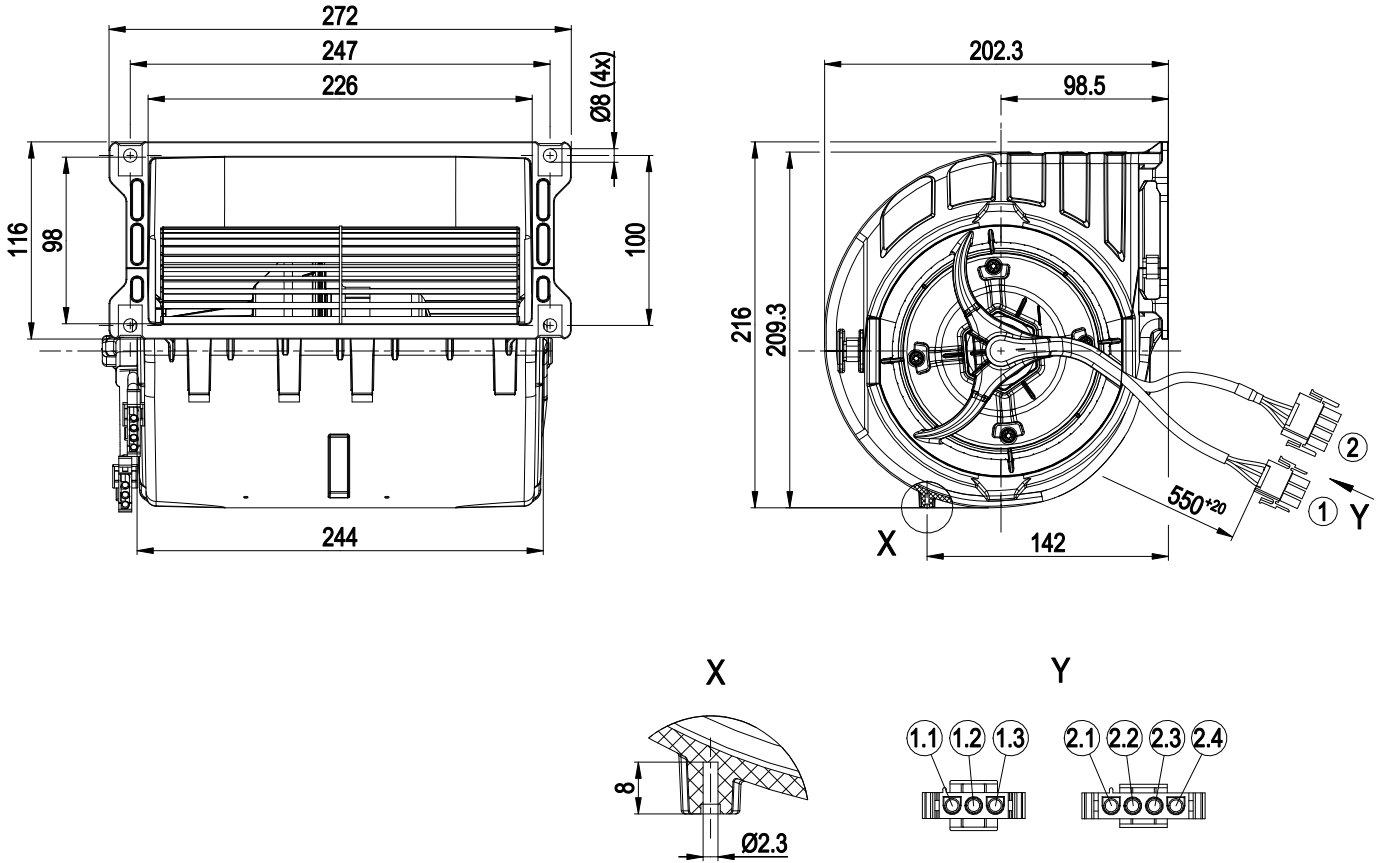

1	Cable PVC AWG20 3-pole connector housing TE 2178473-3, 3x plug pin TE 926887-1
1.1	FE (green/yellow)
1.2	N (blue)
1.3	L (black)
2	Cable PVC AWG20 4-pole connector housing TE 350779-5, 3x plug pin TE 926887-1
2.1	not used
2.2	GND (blue)
2.3	PWM (yellow)
2.4	Fan good / fan bad (white)



ebmpapst

EC centrifugal fan

forward-curved, dual-intake

with housing (flange)

Connection diagram

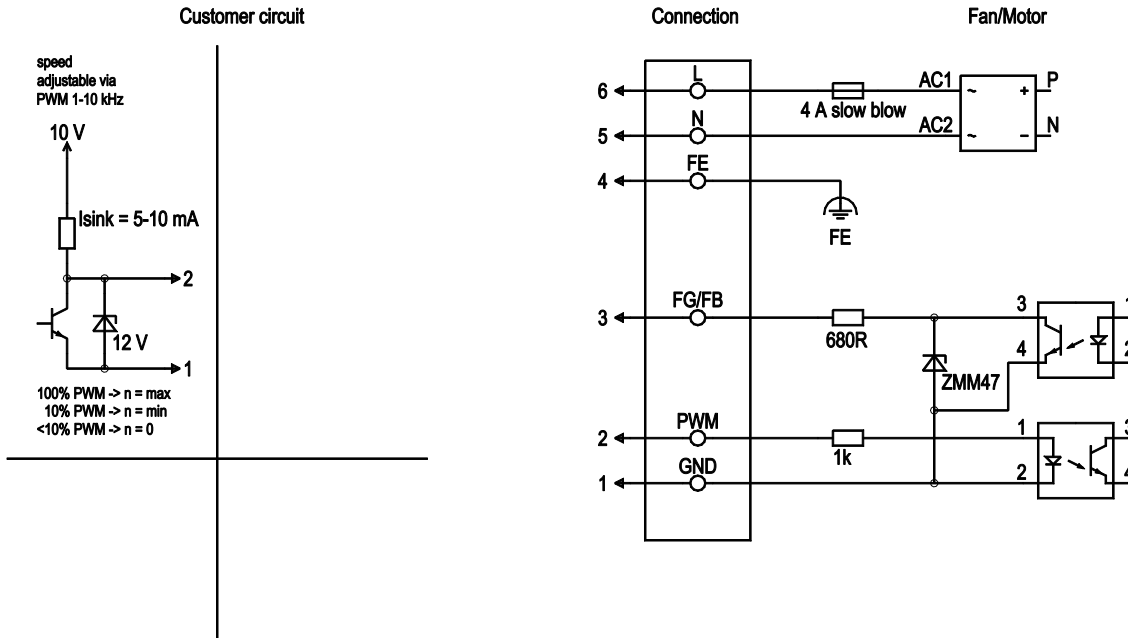

No.	Conn.	Designation	Color	Function/assignment
	6	L	black	Power supply, phase, see nameplate for voltage range
	5	N	blue	Power supply, neutral conductor, see nameplate for voltage range
	4	FE	green/yellow	Functional ground conductor
	3	FG/FB	white	Fan good / fan bad: open collector, fan good = high, electrically isolated, $I_{sink} \text{ max} = 10 \text{ mA}$
	2	PWM	yellow	Control input PWM, impedance 1 k Ω ; SELV
	1	GND	blue	Reference ground for control interface, SELV



EC centrifugal fan

forward-curved, dual-intake
with housing (flange)

Curves: Air performance 50 Hz

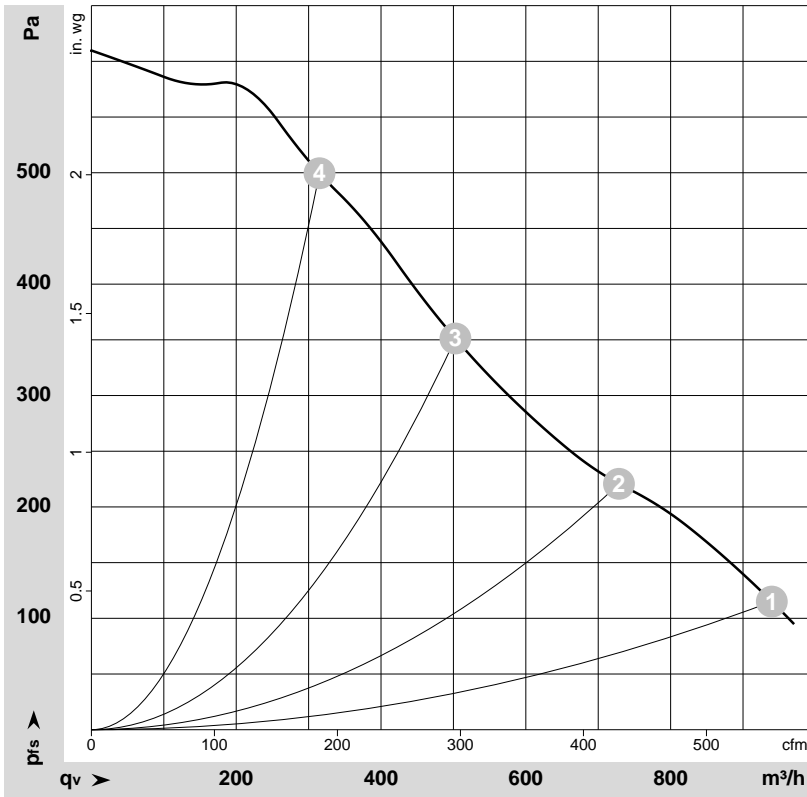

$\rho = 1.15 \text{ kg/m}^3 \pm 2 \%$

Measurement: LU-166068-1

Air performance measured according to ISO 5801 installation category A. For detailed information on the measurement setup, contact ebmpapst. Intake sound level: Sound power level according to ISO 13347 / sound pressure level measured at 1 m distance from fan axis. The values given are valid under the specified measuring conditions and may vary due to conditions of installation. For deviations from the standard configuration, the parameters have to be checked on the installed unit.

Measured values

	Wired	U	f	n	P _{ed}	I	LpA _{in}	LwA _{in}	q _v	P _{fs}	q _v	P _{fs}
		V	Hz	min ⁻¹	W	A	dB(A)	dB(A)	m ³ /h	Pa	cfm	in. wg
1	1~	230	50	1840	165	1.20	61	72	940	115	555	0.46
2	1~	230	50	2125	165	1.20	61	72	730	220	430	0.88
3	1~	230	50	2555	165	1.20	64	75	505	350	295	1.41
4	1~	230	50	3030	165	1.20	67	77	315	500	185	2.01

Wired = Wiring · U = Voltage · f = Frequency · n = Speed (rpm) · P_{ed} = Power consumption · I = Current draw · LpA_{in} = Sound pressure level intake side · LwA_{in} = Sound power level intake side
q_v = Air flow · P_{fs} = Pressure increase

