

B2E133-AM47-09 ebmpapst Datasheet

sales@fansco.com

www.fansco.com

Limited partnership · Headquarters Muldingen  
 County court Stuttgart · HRA 590344

General partner Elektrobau Muldingen GmbH · Headquarters Muldingen  
 County court Stuttgart · HRB 590142

## Nominal data

Type	B2E133-AM47-09		
Motor	M2E068-DF		
Phase		1~	1~
Nominal voltage	VAC	230	230
Frequency	Hz	50	60
Type of data definition		fa	ml
Valid for approval / standard		CE	CE
Speed	min <sup>-1</sup>	1500	1800
Power input	W	190	200
Current draw	A	0.84	0.88
Motor capacitor	µF	3	3
Capacitor voltage	VDB	450	450
Min. back pressure	Pa	0	100
Min. ambient temperature	°C	-25	-25
Max. ambient temperature	°C	55	45
Starting current	A	0.9	0.9

ml = Max. load · me = Max. efficiency · fa = Running at free air · cs = Customer specs · cu = Customer unit  
 Subject to alterations



### Technical features

<b>Mass</b>	2.7 kg
<b>Size</b>	133 mm
<b>Surface of rotor</b>	Coated in black
<b>Material of impeller</b>	Sheet steel, coated in black
<b>Direction of rotation</b>	Clockwise, seen on rotor
<b>Type of protection</b>	IP 44; Depending on installation and position
<b>Insulation class</b>	"F"
<b>Humidity (F)/environmental protection class (H)</b>	F2-2
<b>Max. permissible ambient motor temp. (transp./ storage)</b>	+ 80 °C
<b>Min. permissible ambient motor temp. (transp./storage)</b>	- 40 °C
<b>Mounting position</b>	Any
<b>Condensate discharge holes</b>	None
<b>Operation mode</b>	S1
<b>Motor bearing</b>	Ball bearing
<b>Touch current acc. IEC 60990 (measuring network Fig. 4, TN system)</b>	< 0.75 mA
<b>Motor protection</b>	Thermal overload protector (TOP) wired internally
<b>Cable exit</b>	Variable
<b>Protection class</b>	I (if protective earth is connected by customer)
<b>Product conforming to standard</b>	EN 60335-1; CE



## Product drawing

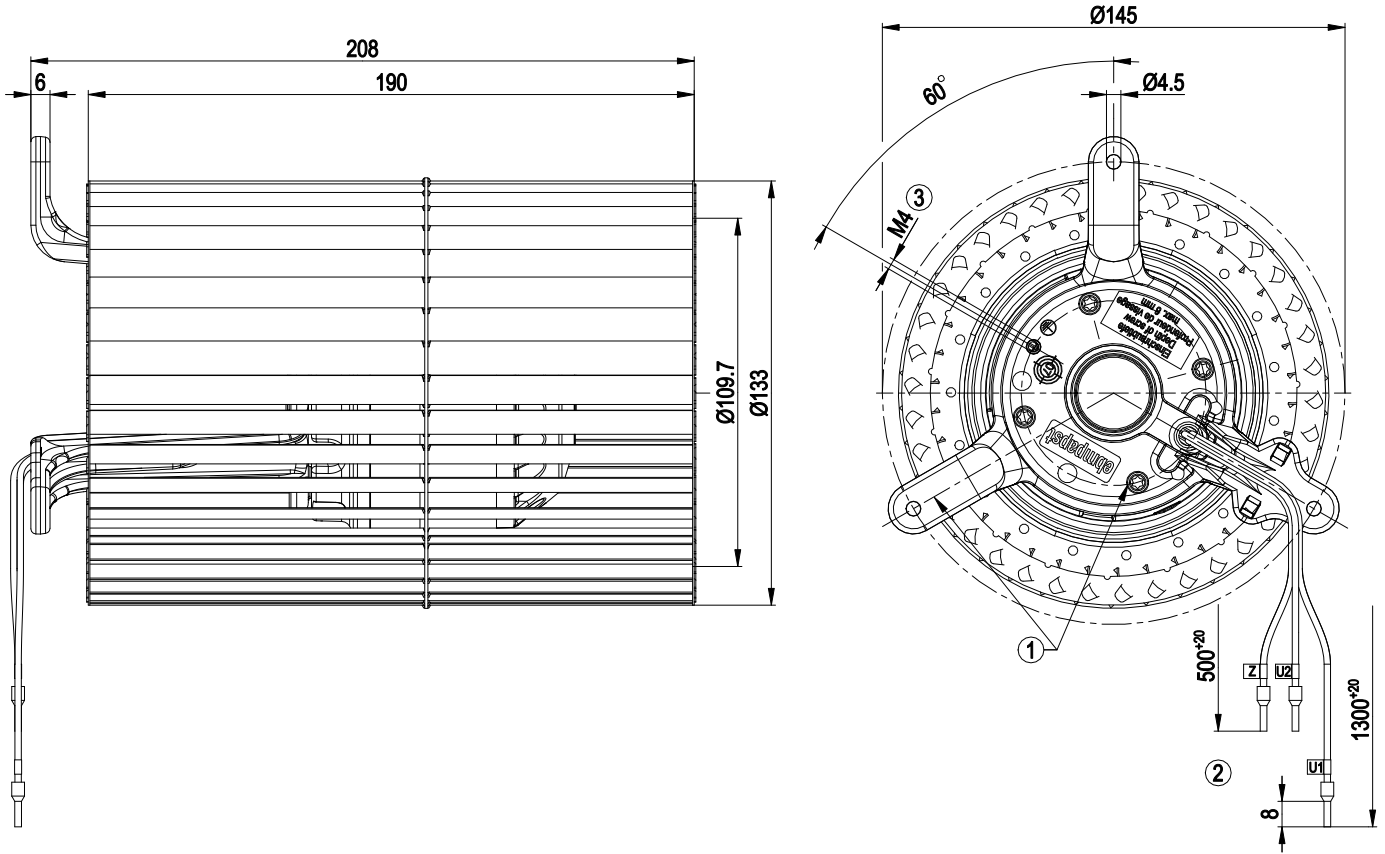

- |   |   |
|---|---|
| 1 | 1x carrying ring 09670-2-9935 and 4x cheese-head screw M4x8 included separately |
| 2 | Connection line Raychem AWG24, 3x crimped core-end sleeve                       |
| 3 | Thread reach max. 8 mm  |

## Connection screen

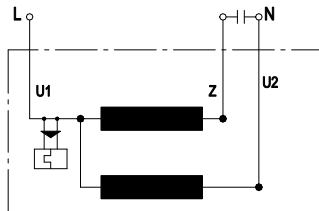

U1	red	Z	red	U2	red
----	-----	---	-----	----	-----

## Charts: Air flow 50 Hz

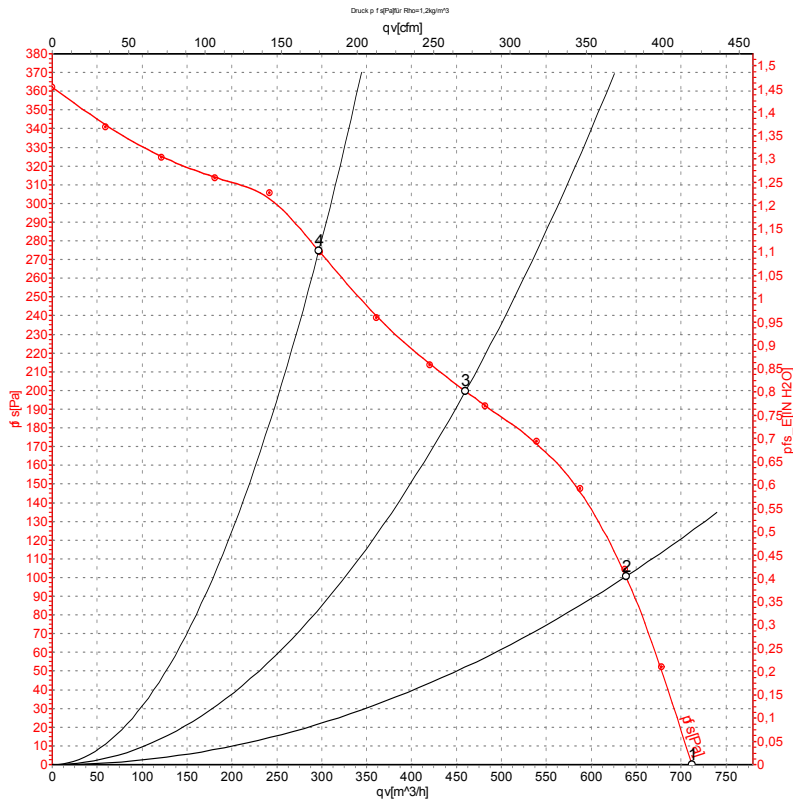

Measurement: LU-105263-1

Air performance measured as per ISO 5801 Installation category A. For detailed information on the measuring set-up, please contact ebmpapst. Suction-side noise levels: L<sub>wA</sub> measured as per ISO 13347 / L<sub>pA</sub> measured with 1m distance to fan axis. The values given are valid under the measuring conditions mentioned above and may vary according to the actual installation situation. With any deviation from the standard set-up, the specific values have to be checked and reviewed with the unit installed.

## Measured values

	U	f	n	P <sub>e</sub>	I	qv	p <sub>fs</sub>
	V	Hz	min <sup>-1</sup>	W	A	m <sup>3</sup> /h	Pa
1	230	50	1500	190	0.84	710	0
2	230	50	1890	164	0.72	640	100
3	230	50	2310	141	0.61	460	200
4	230	50	2570	118	0.52	295	275

U = Supply voltage · f = Frequency · n = Speed · P<sub>e</sub> = Power input · I = Current draw · qv = Air flow · p<sub>fs</sub> = Pressure increase



## Charts: Air flow 60 Hz

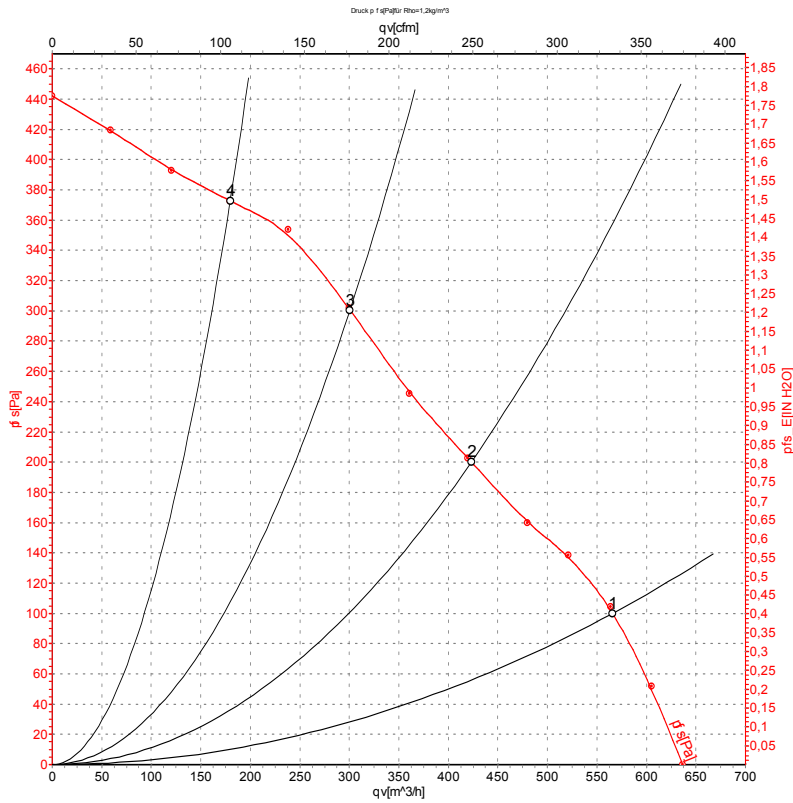

Measurement: LU-105265-1

Air performance measured as per ISO 5801 Installation category A. For detailed information on the measuring set-up, please contact ebm-papst. Suction-side noise levels: L<sub>wA</sub> measured as per ISO 13347 / L<sub>pA</sub> measured with 1m distance to fan axis. The values given are valid under the measuring conditions mentioned above and may vary according to the actual installation situation. With any deviation from the standard set-up, the specific values have to be checked and reviewed with the unit installed.

## Measured values

	U	f	n	P <sub>e</sub>	I	q <sub>v</sub>	p <sub>fs</sub>
	V	Hz	min <sup>-1</sup>	W	A	m <sup>3</sup> /h	Pa
1	230	60	1800	200	0.88	565	100
2	230	60	2310	181	0.78	425	200
3	230	60	2685	170	0.74	300	300
4	230	60	2945	159	0.70	180	375

U = Supply voltage · f = Frequency · n = Speed · P<sub>e</sub> = Power input · I = Current draw · q<sub>v</sub> = Air flow · p<sub>fs</sub> = Pressure increase

