

Product Data Sheet **9204307001**
VWCH119FSJMS
AC 4400 FNN

ebmpapst

engineering a better life



AC 4400 FNN

INDEX

1 General 3

2 Mechanics 3

2.1 General 3

2.2 Connections 3

3 Operating Data 4

3.1 Electrical Interface - Input 4

3.2 Electrical Operating Data 4

3.3 Electrical Features 5

3.4 Aerodynamics 6

3.5 Sound Data 7

4 Environment 8

4.1 General 8

4.2 Climatic Requirements 8

5 Safety 9

5.1 Electrical Safety 9

5.2 Approval Tests 9

6 Reliability 10

6.1 General 10

1 General

Fan type	Axial
Rotating direction looking at rotor	Counterclockwise
Airflow direction	Air outlet over struts
Bearing system	Ball bearing
Mounting position - shaft	Any

2 Mechanics

2.1 General

Width	119,0 mm	
Height	119,0 mm	
Depth	58,0 mm	
Diameter	0,0 mm	
Mass	0,370 kg	
Housing material	Plastic	
Impeller material	Plastic	

2.2 Connections

Electrical connection	Wires	
Lead wire length	L = 450 mm	
Tolerance	+ - 10,0 mm	
Tube length	S = 15 mm	
Tolerance	+ - 5 mm	
Wire size (AWG)	22	
Insulation diameter		
Plug	See drawing	
Contact	See drawing	

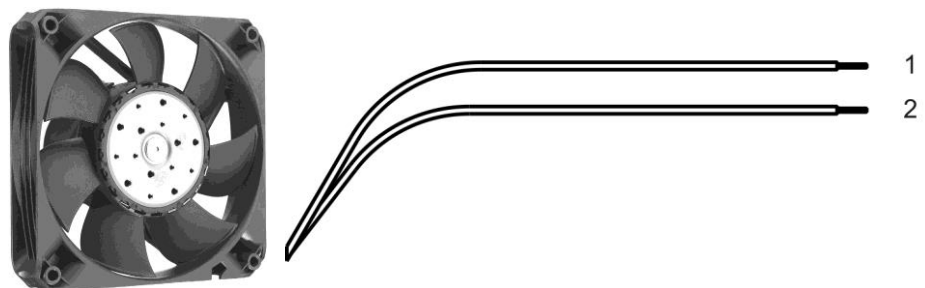

Wire	Color	Operation
1	black	L
2	black	N

3 Operating Data

3.1 Electrical Interface - Input

External voltage supply for input and output signals must be SELV conform.

Control input	None
---------------	------

Features

3.2 Electrical Operating Data

Features	Condition	Symbol	Values			
Voltage range Tolerance		U	85 V			265 V
Nominal voltage		U _N		115	230 V	
Frequency		f	50 Hz / 60 Hz			
Power consumption Tolerance	$\Delta p = 0$	P	12 W + - 15 %			
Current consumption Tolerance	$\Delta p = 0$	I _{RMS}	230 mA + - 15 %	170 mA + - 20 %	100 mA + - 15 %	100 mA + - 20 %
Speed Tolerance	$\Delta p = 0$	n	4.850 1/min + - 10 %			

3.3 Electrical Features

Electronic function	None	
Locked rotor protection	Auto restart	
Clock signal at locked rotor	t_3/t_4 typical: 0,25 s / 20 s	

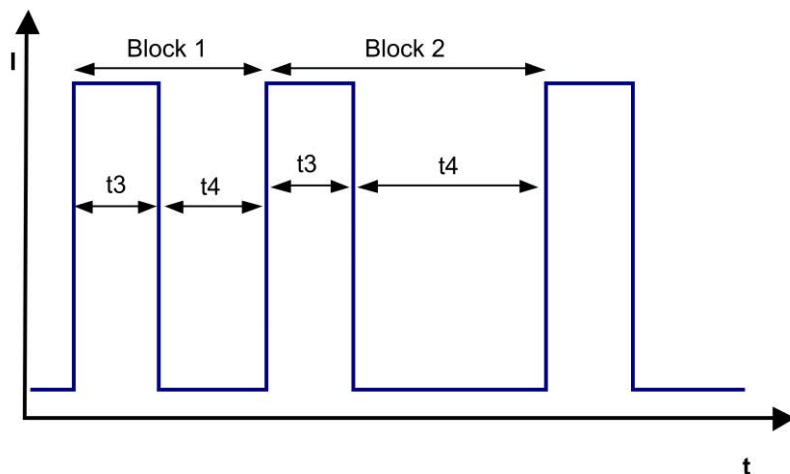

3.4 Aerodynamics

Measurement conditions: Measured with a double chamber intake rig acc. to DIN EN ISO 5801. Normal air density = 1,2 kg/m³; Temperature 23°C +/- 3°C; In the intake and outlet area should not be any solid obstruction within 0,5 m. Motor shaft horizontal. The information is only valid under the specified test conditions and may be changed by the installation conditions. If there are deviations from the standard test conditions, the characteristic values must be checked under the installed conditions.

a) Operation condition: 4.850 1/min at free air flow Frequency: 50 Hz Nominal voltage: 230 V

Max. free-air flow ($\Delta p = 0 / \dot{v} = \text{max.}$)	205,0 m ³ /h
Max. static pressure ($\Delta p = \text{max.} / \dot{v} = 0$)	168 Pa

b) Operation condition: 4.850 1/min at free air flow Frequency: 60 Hz Nominal voltage: 115 V

Max. free-air flow ($\Delta p = 0 / \dot{v} = \text{max.}$)	205 m ³ /h
Max. static pressure ($\Delta p = \text{max.} / \dot{v} = 0$)	168 Pa

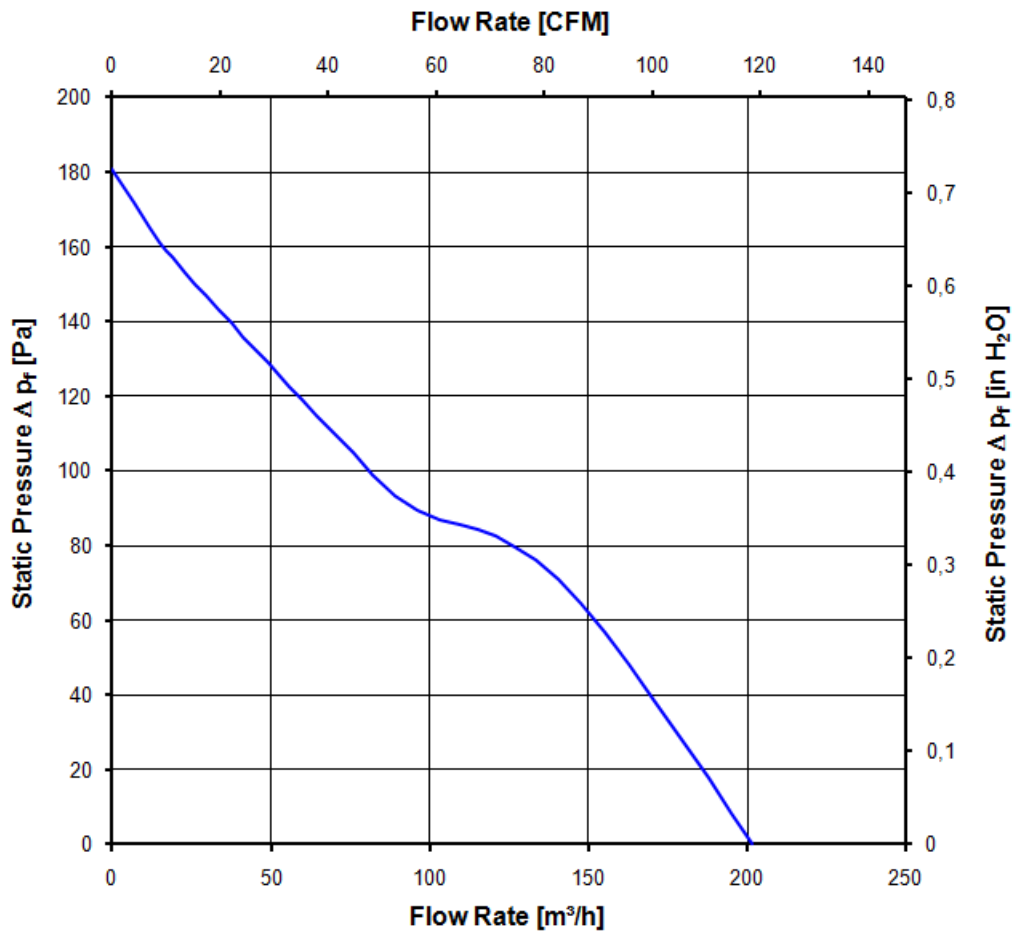

3.5 Sound Data

Measurement conditions: Sound pressure level: 1 meter distance between microphone and the air intake.
 Sound power level: Acc. to DIN 45635 part 38 (ISO 10302)
 Measured in a semianechoic chamber with a background noise level of $L_p(A) < 5 \text{ dB(A)}$
 For further measurement conditions see chapter aerodynamics.

a) Operation condition:
 4.850 1/min at free air flow Frequency: 50 Hz Nominal voltage: 230 V

Optimal operating point	128,0 m3/h @ 75 Pa	
Sound power level at the optimal operating point	6,2 bel(A)	
Sound pressure level at free air flow, measured in rubber bands	53,0 dB(A)	

b) Operation condition:
 4.850 1/min at free air flow Frequency: 60 Hz Nominal voltage: 115 V

Optimal operating point	128,0 m3/h @ 75 Pa	
Sound power level at the optimal operating point	6,2 bel(A)	
Sound pressure level at free air flow, measured in rubber bands	53,0 dB(A)	

4 Environment

4.1 General

Min. permitted ambient temperature TU min.	-20 °C	
Max. permitted ambient temperature TU max.	70 °C	
Min. permitted storage temperature TL min.	-40 °C	
Max. permitted storage temperature TL max.	80 °C	

4.2 Climatic Requirements

Humidity requirements	humid heat, constant; according to DIN EN 60068-2-78, 14 days	
Water exposure	None	
Dust requirements	None	
Salt fog requirements	None	

Permitted application area:

The product is intended for use in sheltered rooms with controlled temperature and controlled humidity. Directly exposure to water must be avoided.

Pollution degree 1 (according DIN EN 60664-1)

There is either no pollution or it occurs only dry, non-conductive pollution. The pollution has no negative impact.

5 Safety

5.1 Electrical Safety

A verification of thermal conditions (normal and abnormal operation) as well as the protection against electric shock, ingress of solid foreign objects and water has to be done in conjunction with the appliance.

Test voltage HV type test	1500 V
Unit test voltage	VAC
Time type test HV	1 s
Insulation resistance	RI > 10 MOhm
Protection class	built-in fan

5.2 Approval Tests

CE	EC Declaration of Conformity	Yes
EAC	Eurasian Conformity	Yes
UL	Underwriters Laboratories	Yes / UL507, Electric Fans E38324
VDE	Association for Electrical, Electronic and Information Technologies	Yes / Approval acc. to EN 60335 (VDE 0700) - Safety for household and similar electrical appliances
CSA	Canadian Standards Association	Yes / C22.2 No. 113 Fans and Ventilators
CCC	China Compulsory Certification	Yes / GB 12350 Safety Requirements for small Power Motors

According to the guidelines on the application of Directive 2006/95/EC, chapter III: Scope of the "low voltage" directive, paragraph: Are "components" included in the scope? the following has to be applied:

However, some types of electrical devices, designed and manufactured for being uses as basic components to be incorporated into other electrical equipment, are such that their safety to a very large extent depends on how they are integrated into the final product and the overall characteristics of the final product. These basic components include electronic and certain other components.

Taking into account these objectives of the "Low Voltage" Directive, such basic components, the safety of which can only, to a very large extend, be assessed taking into account, how they are incorporated and for which a risk assessment cannot be undertaken, then they are not covered as such by the Directive. In particular, they must not be CE marked unless covered by other Community legislation that requires CE marking.

6 Reliability

6.1 General

Life expectancy L10 at TU = 40 °C	60.000 h	
Life expectancy L10 at TU max.	30.000 h	
Life expectancy L10 acc. to IPC 9591 at TU = 40 °C	102.500 h	

Copying of this document, and drawing, in whole or in part, or the use or communication of the contents thereof, for
 reproduction without express authorisation, offenders are liable to the payment of damages. All rights are reserved.
 In the event of the grant of a patent or the registration of a utility model or design.

Schulzwaremwerk nach DIN ISO 9006 (nachweislich)
 Refer to production notes DIN ISO 9006

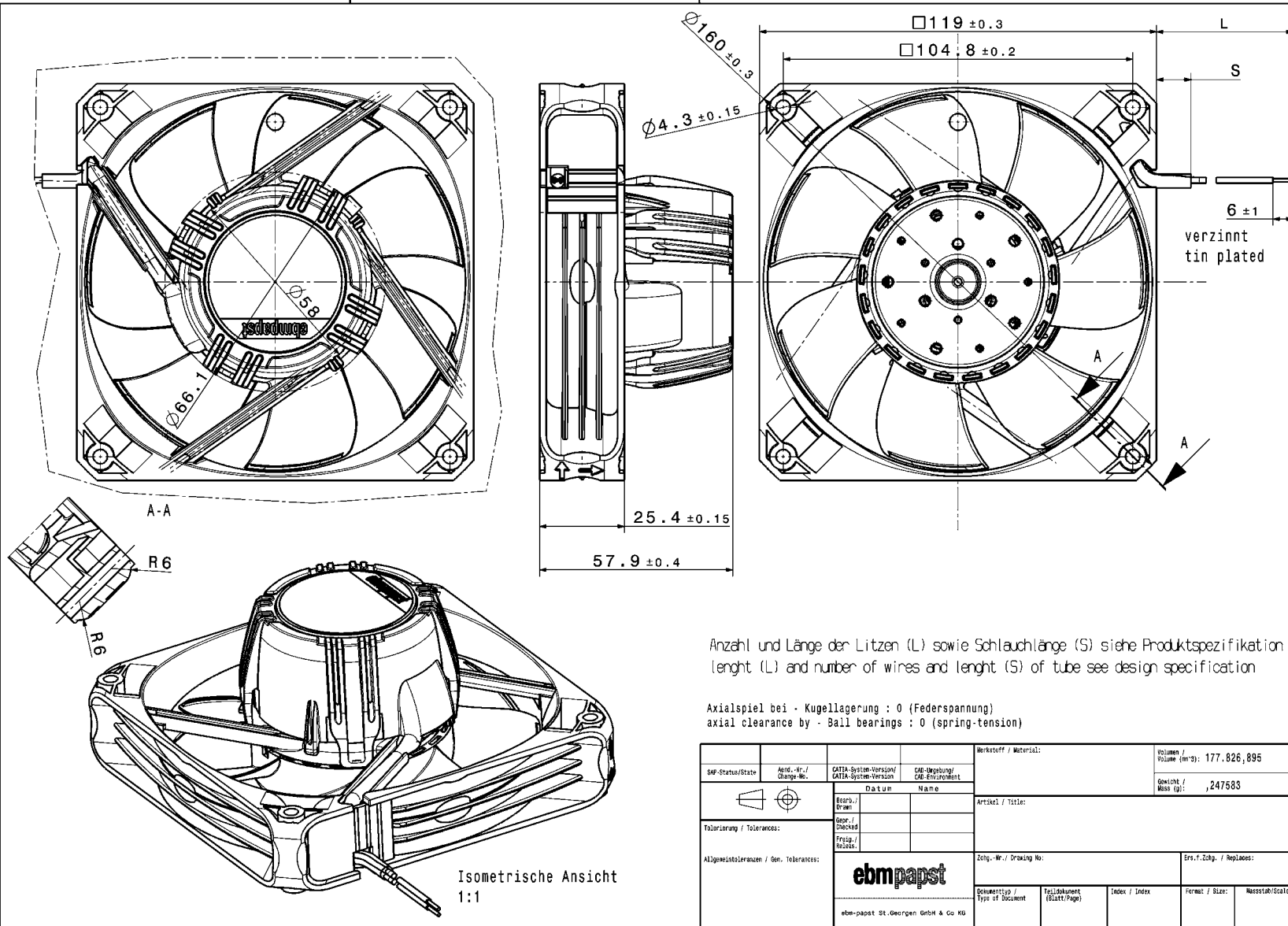

Anzahl und Länge der Litzen (L) sowie Schlauchlänge (S) siehe Produktspezifikation
 length (L) and number of wires and length (S) of tube see design specification

Axialspiel bei - Kugellagerung : 0 (Federspannung)
 axial clearance by - Ball bearings : 0 (spring-tension)

SAP-Status/State	Änd.-Nr./ Change-No.	CATIA-System-Version/ CATIA-system-version	CAD-Menge/ CAD-Environment	Werkstoff / Material:	Volumen / Volume (cm ³): 177,826,895
	Datum Name				Gewicht / Mass (g): 247583
Tolerierung / Tolerances:	Bearb./ Exec.	Gepr./ Checked	Freig./ Released	Artikel / Title:	
	Allgemeintoleranzen / Gen. Tolerances:			Zchg.-Nr. / Drawing No.	
 ebmpapst ebm-papst St. Georgen GmbH & Co KG			Ers.-f.Zchg. / Replaces:		
			Dokumenttyp / Type of Document	Teildokument (Blatt/Page)	Index / Index