

A8D800-AJ01-02 ebmpapst Datasheet
 sales@fansco.com
 www.fansco.com

Limited partnership · Headquarters Mulfingen
 County court Stuttgart · HRA 590344

General partner Elektrobau Mulfingen GmbH · Headquarters Mulfingen
 County court Stuttgart · HRB 590142



Nominal data

Type	A8D800-AJ01-02						
Motor	M8D138-LA						
Phase		3~	3~	3~	3~	3~	3~
Nominal voltage	VAC	400	400	400	400	480	480
Connection		Δ	Y	Δ	Y	Δ	Y
Frequency	Hz	50	50	60	60	60	60
Type of data definition		ml	ml	ml	ml	ml	ml
Valid for approval / standard		CE	CE	CE	CE	CE	CE
Speed	min ⁻¹	660	515	750	495	790	580
Power input	W	980	570	1100	550	1250	740
Current draw	A	2.41	1.21	2.43	1.2	2.53	1.3
Max. back pressure	Pa	105	57	65	25	65	35
Min. ambient temperature	°C	-40	-40	-40	-40	-40	-40
Max. ambient temperature	°C	65	65	60	60	60	60
Starting current	A	6.0	2.0	5.5	1.8	6.6	2.2

ml = Max. load · me = Max. efficiency · fa = Running at free air · cs = Customer specs · cu = Customer unit
 Subject to alterations

Data according to ErP directive

Installation category	A
Efficiency category	Static
Variable speed drive	No
Specific ratio*	1.00

* Specific ratio = $1 + p_s / 100\,000\text{ Pa}$

		Actual	Request 2013	Request 2015
Overall efficiency η_{es}	%	33.4	29.4	33.4
Efficiency grade N		40	36	40
Power input P_e	kW	0.89		
Air flow q_v	m ³ /h	12045		
Pressure increase p_{fs}	Pa	85		
Speed n	min ⁻¹	675		

Data definition with optimum efficiency. LUJ-71660
 The ErP data is determined using a motor-impeller combination in a standardised measurement configuration.



Technical features

Mass	26.1 kg
Size	800 mm
Surface of rotor	Cast in aluminium
Material of terminal box	ABS plastic, black
Material of blades	Die-cast aluminium
Number of blades	5
Blade angle	0°
Direction of air flow	"A"
Direction of rotation	Counter-clockwise, seen on rotor
Type of protection	IP 54
Insulation class	"F"
Humidity class	F3-1
Max. permissible ambient motor temp. (transp./ storage)	+ 80 °C
Min. permissible ambient motor temp. (transp./storage)	- 40 °C
Mounting position	Shaft horizontal or rotor on bottom; rotor on top on request
Condensate discharge holes	Rotor-side
Operation mode	S1
Motor bearing	Ball bearing
Touch current acc. IEC 60990 (measuring network Fig. 4, TN system)	<= 3.5 mA
Electrical leads	Via terminal box
Motor protection	Thermal overload protector (TOP) brought out
Cable exit	Axial
Protection class	I (if protective earth is connected by customer)
Product conforming to standard	EN 60034; EN 61800-5-1; CE
Approval	EAC; VDE

Product drawing

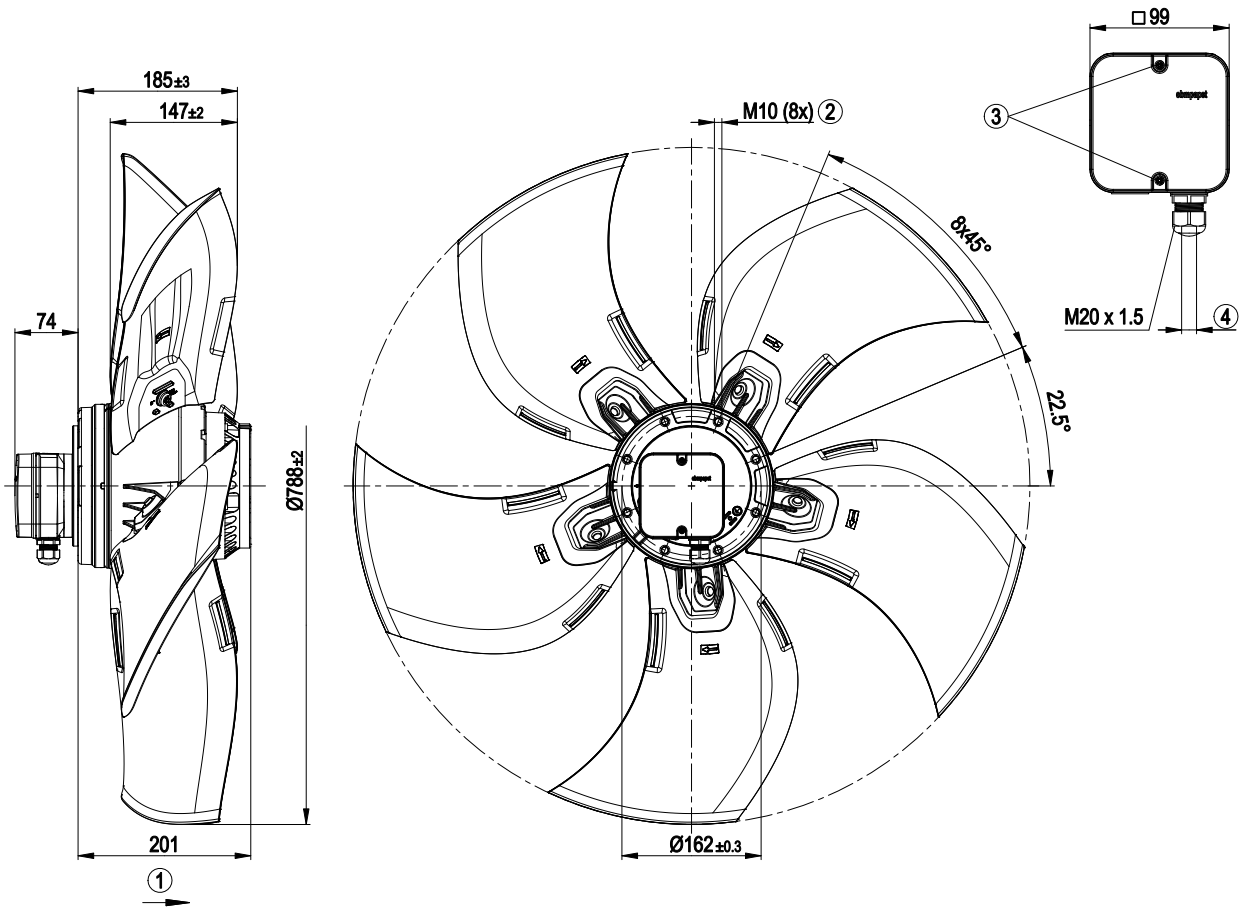

1	Direction of air flow "A"
2	Screw depth max. 18 mm
3	Tightening torque 1.5±0.2 Nm
4	Cable diameter: min. 7 mm, max. 14 mm, tightening torque: 2±0.3 Nm



Connection screen

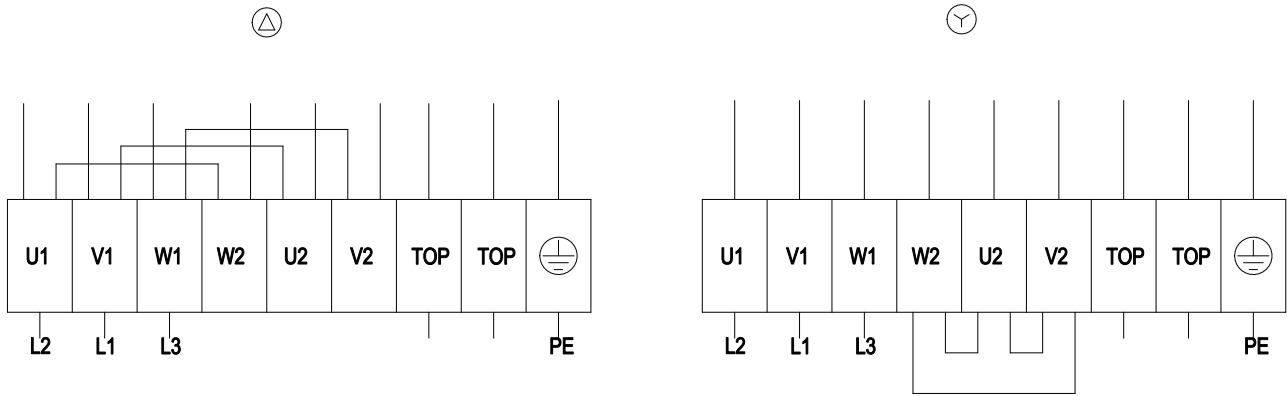

Δ	Delta connection	Y	Star connection	L1	= V1 = blue
L2	= U1 = black	L3	= W1 = brown	W2	yellow
U2	green	V2	white	TOP	2 x grey
PE	green/yellow				

Charts: Air flow 50 Hz

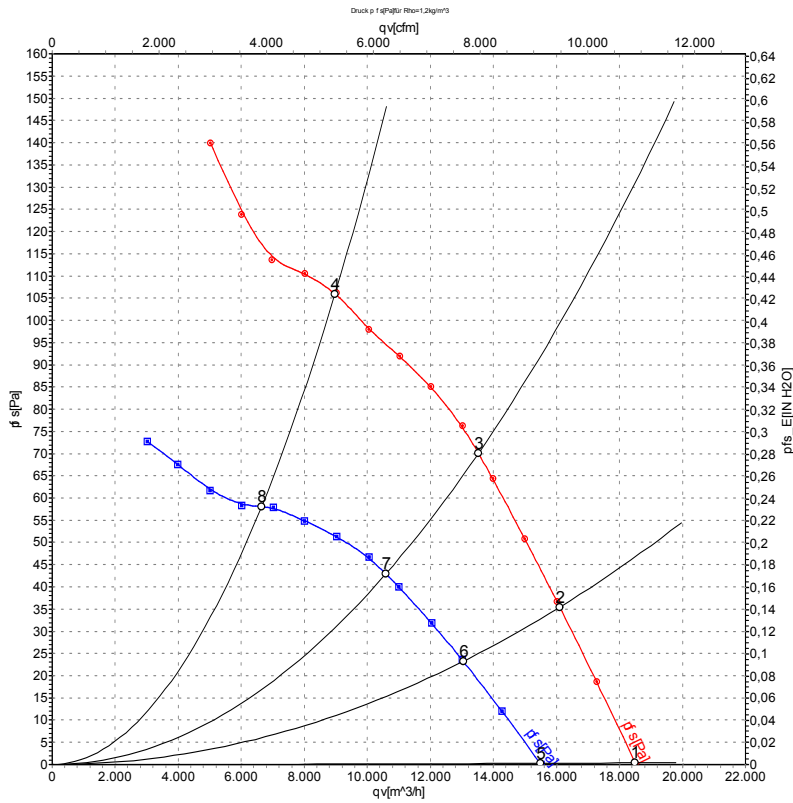

Air performance measured as per ISO 5801 Installation category A. For detailed information on the measuring set-up, please contact ebmpapst. Suction-side noise levels: LwA measured as per ISO 13347 / LpA measured with 1m distance to fan axis. The values given are valid under the measuring conditions mentioned above and may vary according to the actual installation situation. With any deviation from the standard set-up, the specific values have to be checked and reviewed with the unit installed.

Measured values

	Conn.	U	f	n	Pe	I	LpA _{in}	LwA _{in}	qv	p _{fs}
		V	Hz	min ⁻¹	W	A	dB(A)	dB(A)	m ³ /h	Pa
1	Δ	400	50	695	690	2.15	62	67	18520	0
2	Δ	400	50	685	775	2.21	61	67	16100	35
3	Δ	400	50	680	846	2.26	61	67	13530	70
4	Δ	400	50	660	980	2.41	65	72	8975	105
5	Y	400	50	585	465	0.99	59	64	15520	0
6	Y	400	50	555	509	1.08	57	63	13040	23
7	Y	400	50	535	535	1.13	56	62	10580	43
8	Y	400	50	515	570	1.21	58	65	6645	57

Conn. = Connection · U = Supply voltage · f = Frequency · n = Speed · Pe = Power input · I = Current draw · LpA_{in} = Sound pressure level inlet side · LwA_{in} = Sound power level inlet side
 qv = Air flow · p_{fs} = Pressure increase



Charts: Air flow 60 Hz

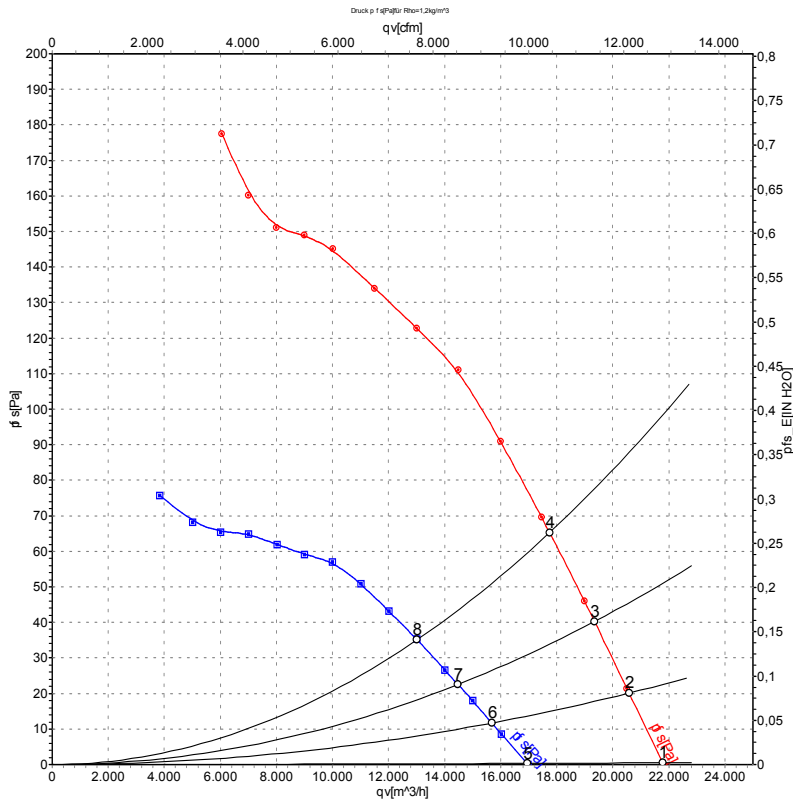

Air performance measured as per ISO 5801 Installation category A. For detailed information on the measuring set-up, please contact ebmpapst. Suction-side noise levels: LwA measured as per ISO 13347 / LpA measured with 1m distance to fan axis. The values given are valid under the measuring conditions mentioned above and may vary according to the actual installation situation. With any deviation from the standard set-up, the specific values have to be checked and reviewed with the unit installed.

Measured values

	Conn.	U	f	n	Pe	I	LpA _{in}	LwA _{in}	qv	p _{fs}
		V	Hz	min ⁻¹	W	A	dB(A)	dB(A)	m ³ /h	Pa
1	Δ	480	60	815	1070	2.33	64	71	21820	0
2	Δ	480	60	810	1134	2.40	64	70	20580	20
3	Δ	480	60	805	1193	2.45	63	70	19350	40
4	Δ	480	60	790	1250	2.53	63	70	17750	65
5	Y	480	60	640	680	1.20	60	66	16980	0
6	Y	480	60	620	702	1.24	59	65	15690	12
7	Y	480	60	605	719	1.27	58	64	14480	22
8	Y	480	60	580	740	1.30	57	64	13020	35

Conn. = Connection · U = Supply voltage · f = Frequency · n = Speed · Pe = Power input · I = Current draw · LpA_{in} = Sound pressure level inlet side · LwA_{in} = Sound power level inlet side
 qv = Air flow · p_{fs} = Pressure increase

