

A8D800-A101-05 ebmpapst Datasheet

sales@fansco.com

www.fansco.com

Limited partnership · Headquarters Mulfingen  
County court Stuttgart · HRA 590344

General partner Elektrobau Mulfingen GmbH · Headquarters Mulfingen  
County court Stuttgart · HRB 590142

## Nominal data

Type	A8D800-A101-05				
Motor	M8D138-LA				
Phase		3~	3~	3~	3~
Nominal voltage	VAC	400	400	480	480
Connection		$\Delta$	Y	$\Delta$	Y
Frequency	Hz	50	50	60	60
Type of data definition		ml	ml	ml	ml
Valid for approval / standard		CE	CE	CE	CE
Speed (rpm)	min <sup>-1</sup>	680	540	800	590
Power input	W	890	590	1300	820
Current draw	A	2.22	1.17	2.53	1.41
Max. back pressure	Pa	100	62	120	70
Min. ambient temperature	°C	-40	-40	-40	-40
Max. ambient temperature	°C	70	70	70	70
Starting current	A	6.6	2.2	7	2.2

ml = Max. load · me = Max. efficiency · fa = Running at free air · cs = Customer specs · cu = Customer unit  
Subject to alterations

## Data according to ErP directive

		Actual	Request 2015			
01 Overall efficiency $\eta_{es}$	%	32.9	32.9	09 Power input $P_e$	kW	0.75
02 Measurement category		A		09 Air flow $q_v$	m <sup>3</sup> /h	12710
03 Efficiency category		Static		09 Pressure increase $p_{fs}$	Pa	69
04 Efficiency grade N		40	40	10 Speed (rpm) n	min <sup>-1</sup>	695
05 Variable speed drive		No		11 Specific ratio*		1.00

Data definition with optimum efficiency.  
The ErP data is determined using a motor-impeller combination in a standardised measurement configuration.

\* Specific ratio =  $1 + p_g / 100\,000\text{ Pa}$

LU-164813



## Technical features

Mass	24 kg
Size	800 mm
Surface of rotor	Cast in aluminium
Material of terminal box	PP plastic
Material of blades	Aluminium sheet insert, sprayed with PP plastic
Number of blades	5
Blade angle	-2°
Direction of air flow	"V"
Direction of rotation	Clockwise, seen on rotor
Type of protection	IP 54
Insulation class	"F"
Humidity (F)/environmental protection class (H)	F3-1
Max. permissible ambient motor temp. (transp./ storage)	+ 80 °C
Min. permissible ambient motor temp. (transp./storage)	- 40 °C
Mounting position	Any
Condensate discharge holes	On rotor and stator sides
Operation mode	S1
Motor bearing	Ball bearing
Touch current acc. IEC 60990 (measuring network Fig. 4, TN system)	<= 3.5 mA
Electrical leads	Via terminal box
Motor protection	Thermal overload protector (TOP) brought out, basic insulation
Protection class	I (if protective earth is connected by customer)
Product conforming to standard	EN 60034-1 (2010); EN 61800-5-1; CE
Approval	VDE; EAC

Product drawing

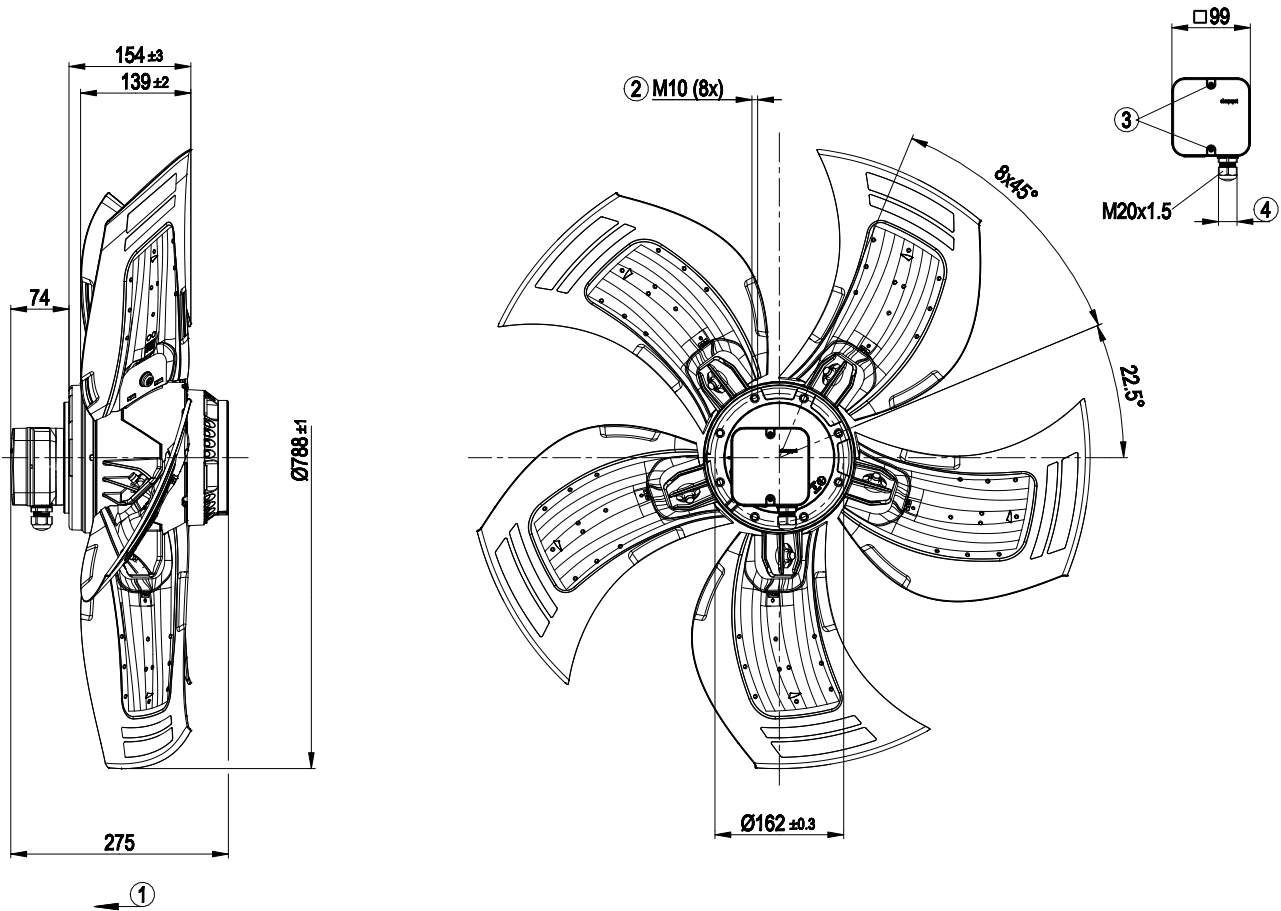

1	Direction of air flow "V"
2	Thread reach max. 18 mm
3	Tightening torque 1.5±0.2 Nm
4	Cable diameter: min. 7 mm, max. 14 mm, tightening torque 2±0.3 Nm



# AC axial fan - HyBlade

sickled blades (S series)

## Connection screen



Δ	Delta connection	Y	Star connection	L1	= U1 = black
L2	= V1 = blue	L3	= W1 = brown	W2	yellow
U2	green	V2	white	TOP	2 x grey
PE	green/yellow				



## Charts: Air flow 50 Hz

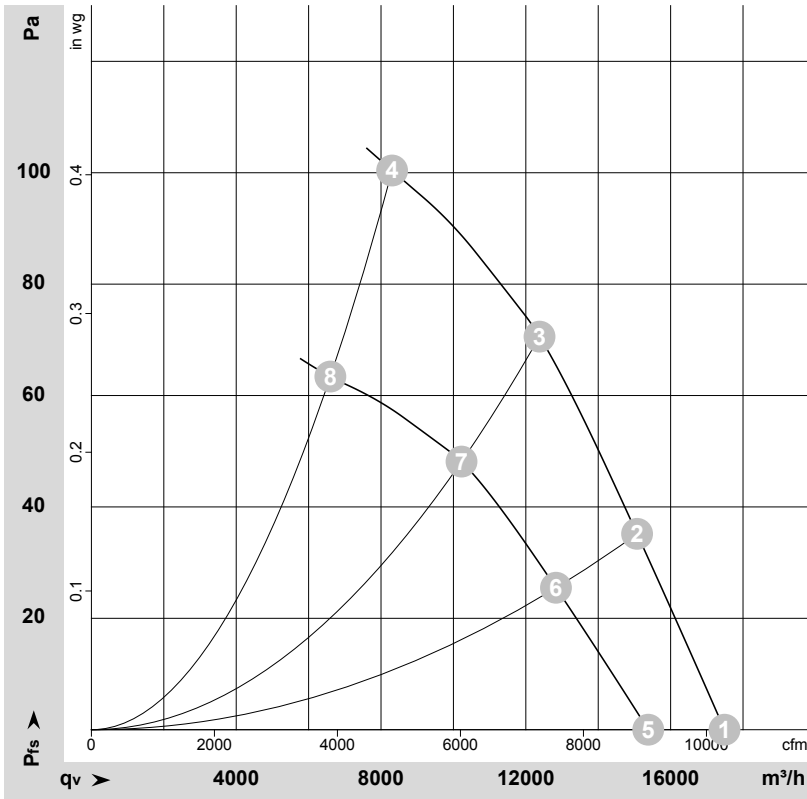

$\rho = 1.15 \text{ kg/m}^3 \pm 2 \%$

Measurement: LU-164813-1  
Measurement: LU-165086-1

Air performance measured as per ISO 5801 Installation category A. For detailed information on the measuring set-up, please contact ebm-papst. Suction-side noise levels: LwA measured as per ISO 13347 / LpA measured with 1m distance to fan axis. The values given are valid under the measuring conditions mentioned above and may vary according to the actual installation situation. With any deviation from the standard set-up, the specific values have to be checked and reviewed with the unit installed.

## Measured values

	Conn.	U	f	n	P <sub>e</sub>	I	LpA <sub>in</sub>	LwA <sub>in</sub>	LwA <sub>out</sub>	q <sub>v</sub>	p <sub>fs</sub>	q <sub>v</sub>	p <sub>fs</sub>
		V	Hz	min <sup>-1</sup>	W	A	dB(A)	dB(A)	dB(A)	m <sup>3</sup> /h	Pa	cfm	inH <sub>2</sub> O
1	Δ	400	50	710	597	1.97	59	66	65	17490	0	10295	0.00
2	Δ	400	50	700	691	2.04	58	64	63	15075	35	8870	0.14
3	Δ	400	50	690	769	2.11	59	66	65	12380	70	7285	0.28
4	Δ	400	50	680	890	2.22	66	73	73	8305	100	4890	0.40
5	Y	400	50	625	431	0.89	57	63	62	15380	0	9055	0.00
6	Y	400	50	595	490	0.99	55	61	60	12835	26	7555	0.10
7	Y	400	50	570	534	1.07	55	61	60	10225	48	6020	0.19
8	Y	400	50	540	590	1.17	59	67	67	6600	63	3885	0.25

Conn. = Connection · U = Supply voltage · f = Frequency · n = Speed (rpm) · P<sub>e</sub> = Power input · I = Current draw · LpA<sub>in</sub> = Sound pressure level inlet side · LwA<sub>in</sub> = Sound power level inlet side  
LwA<sub>out</sub> = Sound power level outlet side · q<sub>v</sub> = Air flow · p<sub>fs</sub> = Pressure increase



## Charts: Air flow 60 Hz

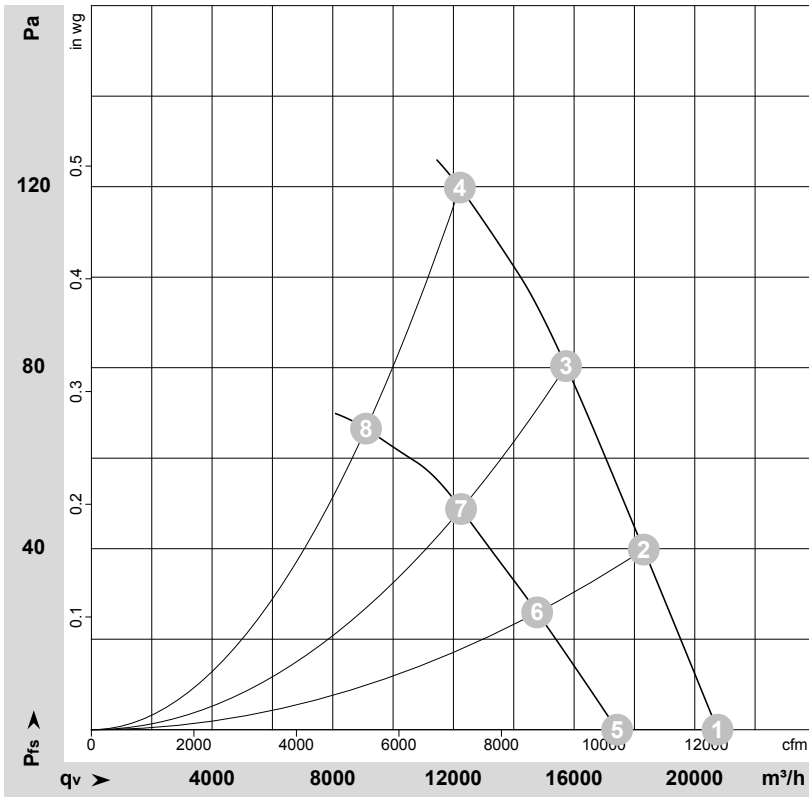

$\rho = 1.15 \text{ kg/m}^3 \pm 2 \%$

Measurement: LU-167725-1  
Measurement: LU-167728-1

Air performance measured as per ISO 5801 Installation category A. For detailed information on the measuring set-up, please contact ebm-papst. Suction-side noise levels: LwA measured as per ISO 13347 / LpA measured with 1m distance to fan axis. The values given are valid under the measuring conditions mentioned above and may vary according to the actual installation situation. With any deviation from the standard set-up, the specific values have to be checked and reviewed with the unit installed.

## Measured values

	Conn.	U	f	n	P <sub>e</sub>	I	LpA <sub>in</sub>	LwA <sub>in</sub>	LwA <sub>out</sub>	q <sub>v</sub>	p <sub>fs</sub>	q <sub>v</sub>	p <sub>fs</sub>
		V	Hz	min <sup>-1</sup>	W	A	dB(A)	dB(A)	dB(A)	m <sup>3</sup> /h	Pa	cfm	inH <sub>2</sub> O
1	Δ	480	60	840	914	2.14	63	70	69	20755	0	12215	0.00
2	Δ	480	60	830	1051	2.27	61	68	68	18310	40	10775	0.16
3	Δ	480	60	820	1159	2.38	63	69	68	15730	80	9260	0.32
4	Δ	480	60	800	1300	2.53	66	73	72	12215	120	7190	0.48
5	Y	480	60	705	663	1.11	59	66	65	17430	0	10260	0.00
6	Y	480	60	665	728	1.22	57	63	62	14775	26	8695	0.10
7	Y	480	60	635	772	1.30	57	63	62	12255	49	7210	0.20
8	Y	480	60	590	820	1.41	58	66	65	9105	67	5360	0.27

Conn. = Connection · U = Supply voltage · f = Frequency · n = Speed (rpm) · P<sub>e</sub> = Power input · I = Current draw · LpA<sub>in</sub> = Sound pressure level inlet side · LwA<sub>in</sub> = Sound power level inlet side  
LwA<sub>out</sub> = Sound power level outlet side · q<sub>v</sub> = Air flow · p<sub>fs</sub> = Pressure increase

