

A8D630-AN01-01 ebmpapst Datasheet

sales@fansco.com

www.fansco.com

Limited partnership · Headquarters Muldingen
County court Stuttgart · HRA 590344General partner Elektrobau Muldingen GmbH · Headquarters Muldingen
County court Stuttgart · HRB 590142

Nominal data

Type	A8D630-AN01-01						
Motor	M8D110-GF						
Phase		3~	3~	3~	3~	3~	3~
Nominal voltage	VAC	400	400	400	400	480	480
Connection		Δ	Y	Δ	Y	Δ	Y
Frequency	Hz	50	50	60	60	60	60
Type of data definition		ml	ml	ml	ml	ml	ml
Valid for approval / standard		-	-	-	-	-	-
Speed (rpm)	min ⁻¹	660	520	725	460	780	560
Power input	W	330	190	430	210	490	270
Current draw	A	0.83	0.39	0.90	0.44	0.94	0.45
Max. back pressure	Pa	60	36	70	30	80	37
Min. ambient temperature	°C	-40	-40	-40	-40	-40	-40
Max. ambient temperature	°C	65	65	55	55	55	55
Starting current	A	1.85	0.62	1.65	0.55		

ml = Max. load · me = Max. efficiency · fa = Running at free air · cs = Customer specs · cu = Customer unit
Subject to alterations

Technical features

Mass	10.1 kg
Size	630 mm
Surface of rotor	Coated in black
Material of terminal box	PP plastic
Material of blades	Press-fitted sheet steel blank, sprayed with PP plastic
Number of blades	5
Direction of air flow	"V"
Direction of rotation	Counter-clockwise, seen on rotor
Type of protection	IP 54
Insulation class	"F"
Humidity (F)/environmental protection class (H)	F4-1
Max. permissible ambient motor temp. (transp./ storage)	+ 80 °C
Min. permissible ambient motor temp. (transp./storage)	- 40 °C
Mounting position	Shaft horizontal or rotor on bottom; rotor on top on request
Condensate discharge holes	Rotor-side
Operation mode	S1
Motor bearing	Ball bearing
Touch current acc. IEC 60990 (measuring network Fig. 4, TN system)	<= 3.5 mA
Electrical leads	Via terminal box
Motor protection	Thermal overload protector (TOP) brought out, basic insulation
Cable exit	Axial
Protection class	I (if protective earth is connected by customer)
Product conforming to standard	EN 61800-5-1
Approval	CCC; VDE; EAC



Product drawing

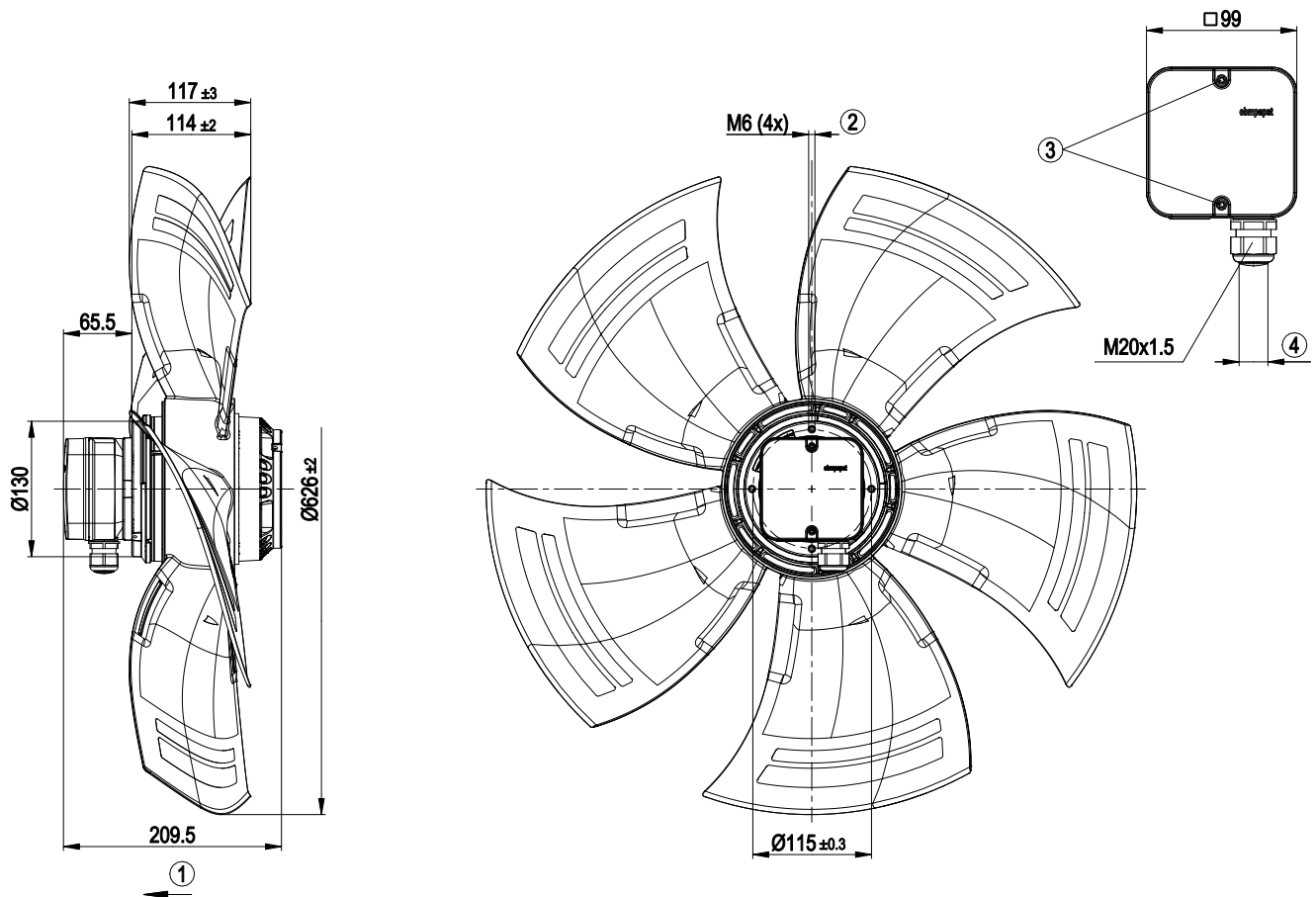

1	Direction of air flow "V"
2	Depth of screw max. 12 mm
3	Tightening torque 1.5±0.2 Nm
4	Cable diameter: min. 6 mm, max. 12 mm, tightening torque: 2±0.3 Nm

Connection screen

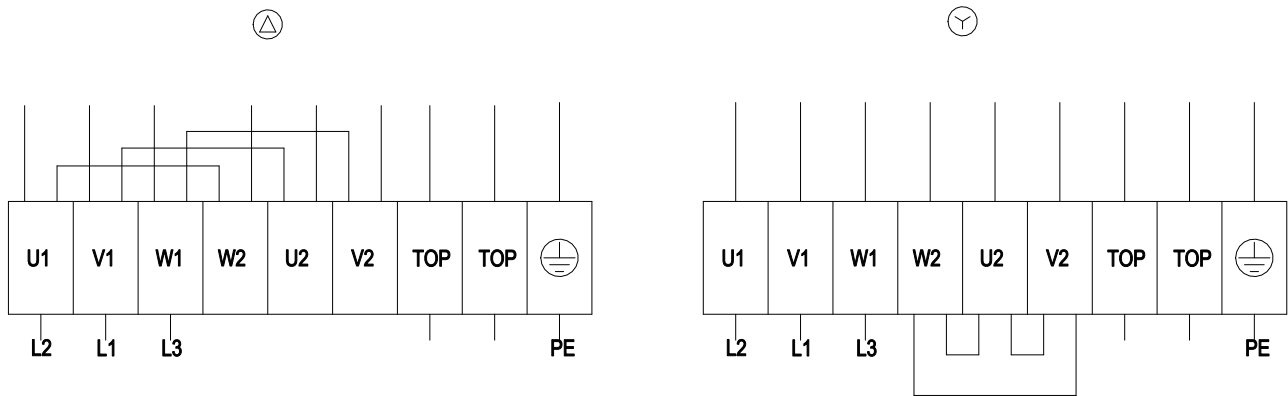

Δ	Delta connection	Y	Star connection	L1	= V1 = blue
L2	= U1 = black	L3	= W1 = brown	W2	yellow
U2	green	V2	white	TOP	2 x grey
PE	green/yellow				

Charts: Air flow 50 Hz

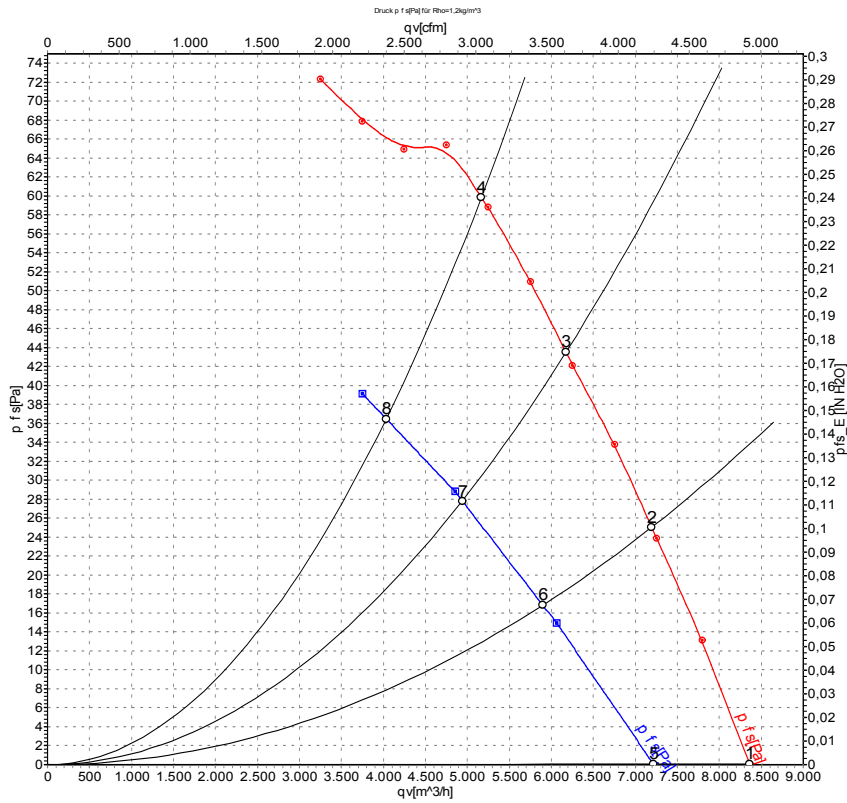

Measurement: LU-105817-1
Measurement: LU-107328-1

Air performance measured as per ISO 5801 Installation category A. For detailed information on the measuring set-up, please contact ebmpapst. Suction-side noise levels: LwA measured as per ISO 13347 / LpA measured with 1m distance to fan axis. The values given are valid under the measuring conditions mentioned above and may vary according to the actual installation situation. With any deviation from the standard set-up, the specific values have to be checked and reviewed with the unit installed.

Measured values

	Conn.	U	f	n	P _e	I	LpA _{in}	LwA _{in}	LwA _{out}	q _v	p _{fs}	q _v	p _{fs}
		V	Hz	min ⁻¹	W	A	dB(A)	dB(A)	dB(A)	m ³ /h	Pa	cfm	inH2O
1	Δ	400	50	700	248	0.79	58	63	62	8360	0	4920	0.00
2	Δ	400	50	685	285	0.81	54	60	60	7195	25	4235	0.10
3	Δ	400	50	675	309	0.82	54	60	59	6175	44	3635	0.18
4	Δ	400	50	660	330	0.83	54	61	60	5165	60	3040	0.24
5	Y	400	50	600	157	0.33	53	59	58	7215	0	4245	0.00
6	Y	400	50	560	176	0.35	50	56	55	5900	17	3470	0.07
7	Y	400	50	535	186	0.37	49	55	54	4940	28	2905	0.11
8	Y	400	50	520	190	0.39	49	55	55	4035	36	2375	0.14

Conn. = Connection · U = Supply voltage · f = Frequency · n = Speed (rpm) · P_e = Power input · I = Current draw · LpA_{in} = Sound pressure level inlet side · LwA_{in} = Sound power level inlet side
LwA_{out} = Sound power level outlet side · q_v = Air flow · p_{fs} = Pressure increase



Charts: Air flow 60 Hz

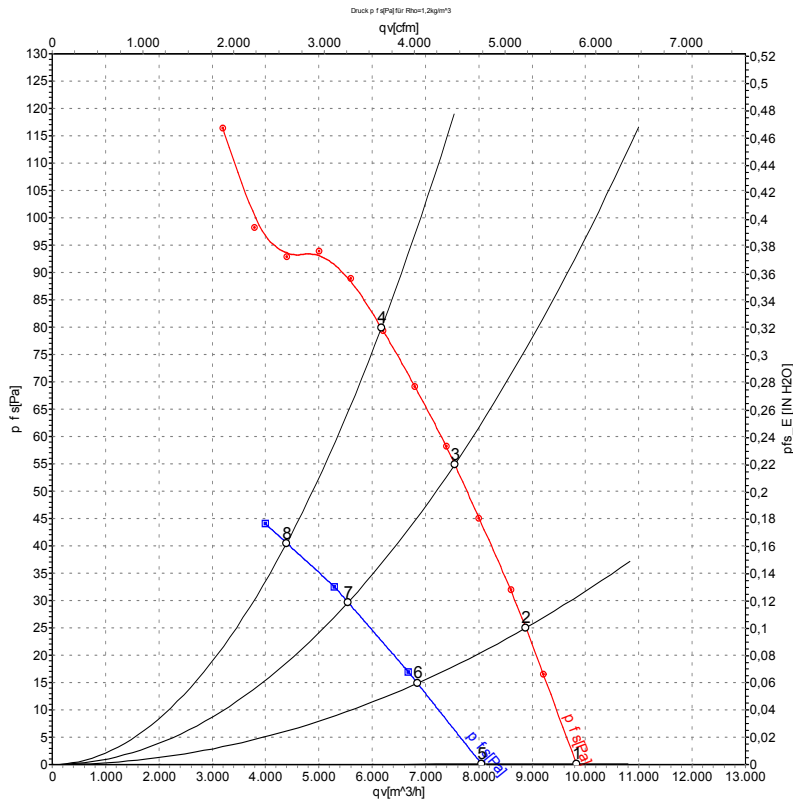

Measurement: LU-105818-1
Measurement: LU-107331-1

Air performance measured as per ISO 5801 Installation category A. For detailed information on the measuring set-up, please contact ebmpapst. Suction-side noise levels: L_{wA} measured as per ISO 13347 / L_{pA} measured with 1m distance to fan axis. The values given are valid under the measuring conditions mentioned above and may vary according to the actual installation situation. With any deviation from the standard set-up, the specific values have to be checked and reviewed with the unit installed.

Measured values

	Conn.	U	f	n	P _e	I	LpA _{in}	LwA _{in}	LwA _{out}	q _v	p _{fs}	q _v	p _{fs}
		V	Hz	min ⁻¹	W	A	dB(A)	dB(A)	dB(A)	m ³ /h	Pa	cfm	inH ₂ O
1	Δ	480	60	820	366	0.84	61	67	66	9830	0	5785	0.00
2	Δ	480	60	810	406	0.88	59	65	64	8880	25	5225	0.10
3	Δ	480	60	790	455	0.91	57	63	63	7545	55	4440	0.22
4	Δ	480	60	780	490	0.94	58	64	63	6175	80	3635	0.32
5	Y	480	60	665	235	0.40	55	61	60	8050	0	4740	0.00
6	Y	480	60	620	251	0.42	52	59	58	6850	15	4030	0.06
7	Y	480	60	580	265	0.44	50	57	56	5545	30	3265	0.12
8	Y	480	60	560	270	0.45	50	57	56	4395	40	2590	0.16

Conn. = Connection · U = Supply voltage · f = Frequency · n = Speed (rpm) · P_e = Power input · I = Current draw · LpA_{in} = Sound pressure level inlet side · LwA_{in} = Sound power level inlet side
LwA_{out} = Sound power level outlet side · q_v = Air flow · p_{fs} = Pressure increase

