

A6E450-AU04-08 ebmpapst Datasheet

sales@fansco.com

www.fansco.com

Limited partnership · Headquarters Muldingen
County court Stuttgart · HRA 590344

General partner Elektrobau Muldingen GmbH · Headquarters Muldingen
County court Stuttgart · HRB 590142



Nominal data

Type	A6E450-AU04-08		
Motor	M6E094-EA		
Phase		1~	1~
Nominal voltage	VAC	230	230
Frequency	Hz	50	60
Type of data definition		ml	ml
Valid for approval / standard		CE	CE
Speed	min ⁻¹	900	990
Power input	W	190	260
Current draw	A	0.86	1.16
Motor capacitor	µF	5	5
Capacitor voltage	VDB	450	450
Max. back pressure	Pa	60	75
Min. ambient temperature	°C	-40	-40
Max. ambient temperature	°C	65	65

ml = Max. load · me = Max. efficiency · fa = Running at free air · cs = Customer specs · cu = Customer unit
Subject to alterations

Data according to ErP directive

Installation category	A
Efficiency category	Static
Variable speed drive	No
Specific ratio*	1.00

* Specific ratio = $1 + p_{fs} / 100\,000\text{ Pa}$

		Actual	Request 2013	Request 2015
Overall efficiency η_{es}	%	25.2	25	29
Efficiency grade N		36.2	36	40
Power input P_e	kW	0.18		
Air flow q_v	m ³ /h	3085		
Pressure increase p_{fs}	Pa	56		
Speed n	min ⁻¹	900		

Data definition with optimum efficiency.
The ErP data is determined using a motor-impeller combination in a standardised measurement configuration.



Technical features

Mass	4.9 kg
Size	450 mm
Surface of rotor	Coated in black
Material of terminal box	ABS plastic, black
Material of blades	Press-fitted sheet steel blank, sprayed with PP plastic
Number of blades	5
Direction of air flow	"A"
Direction of rotation	Clockwise, seen on rotor
Type of protection	IP 54
Insulation class	"F"
Humidity class	F4-1
Max. permissible ambient motor temp. (transp./ storage)	+80 °C
Min. permissible ambient motor temp. (transp./storage)	-40 °C
Mounting position	Shaft horizontal or rotor on bottom; rotor on top on request
Condensate discharge holes	Rotor-side
Operation mode	S1
Motor bearing	Ball bearing
Touch current acc. IEC 60990 (measuring network Fig. 4, TN system)	<= 3.5 mA
Motor protection	Thermal overload protector (TOP) wired internally
Protection class	I (if protective earth is connected by customer)
Product conforming to standard	CE

Product drawing

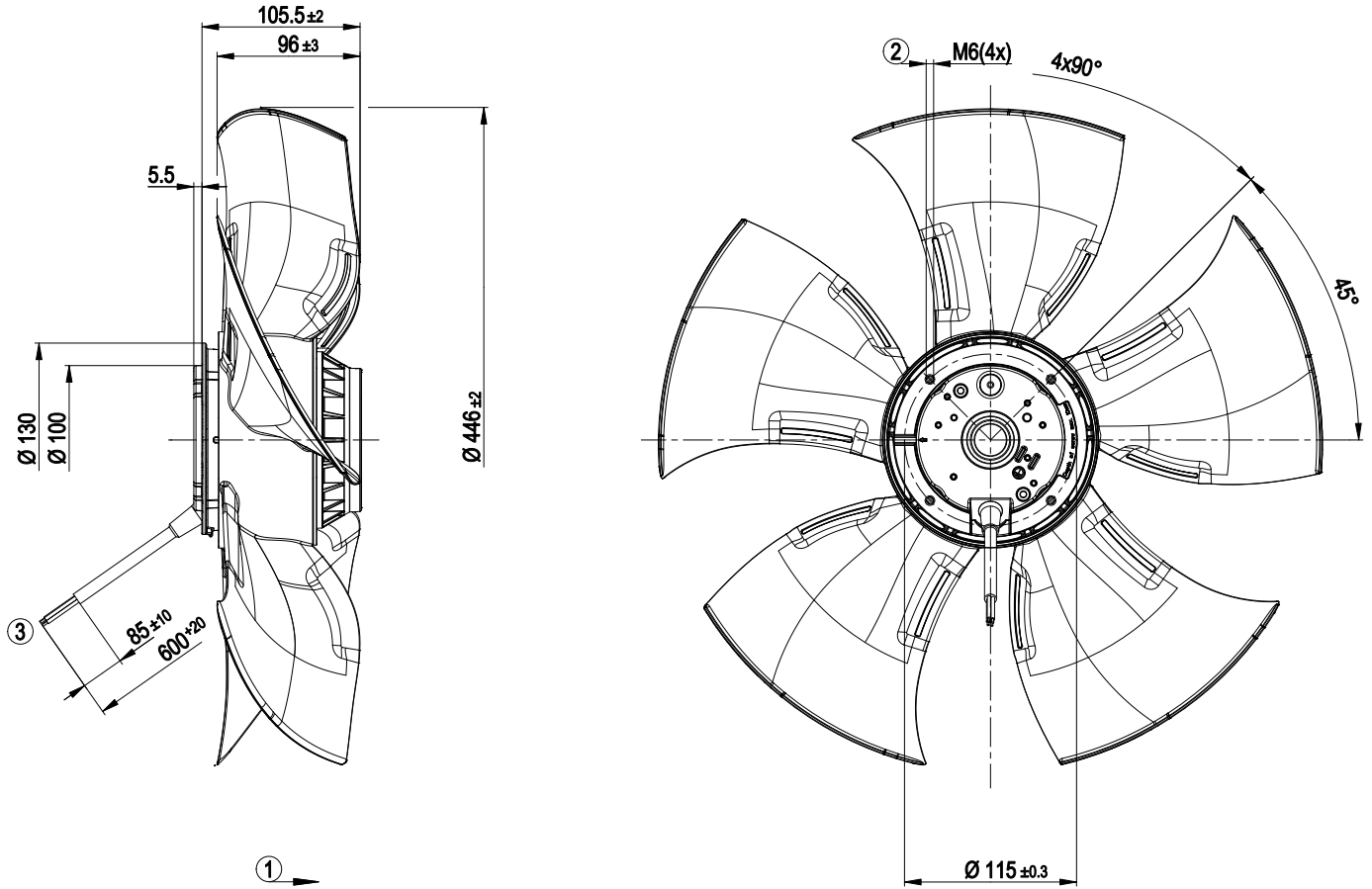

1	Direction of air flow "A"
2	Depth of screw max. 10 mm
3	Connection line silicone 4G 0.5 mm ²

Connection screen

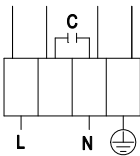

L	= U1 = blue	Z	brown	N	= U2 = black
PE	green/yellow				

Charts: Air flow 50 Hz

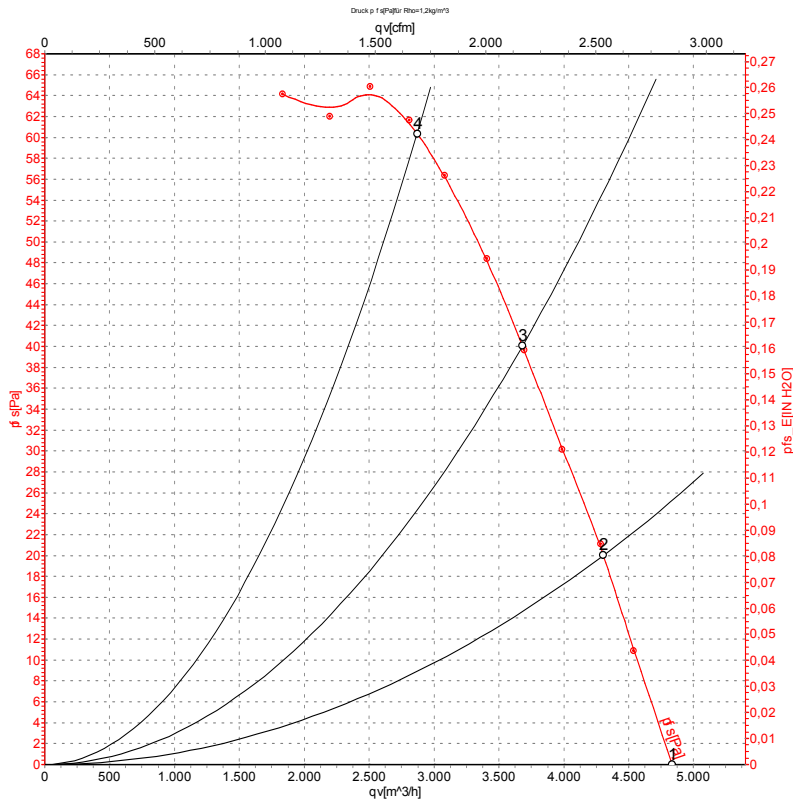

Measurement: LU-106691

Air performance measured as per ISO 5801 Installation category A. For detailed information on the measuring set-up, please contact ebm-papst. Suction-side noise levels: LwA measured as per ISO 13347 / LpA measured with 1m distance to fan axis. The values given are valid under the measuring conditions mentioned above and may vary according to the actual installation situation. With any deviation from the standard set-up, the specific values have to be checked and reviewed with the unit installed.

Measured values

	U	f	n	Pe	I	LpA _{in}	LwA _{in}	LwA _{out}	qv	p _{fs}
	V	Hz	min ⁻¹	W	A	dB(A)	dB(A)	dB(A)	m ³ /h	Pa
1	230	50	925	171	0.79	56	61	62	4830	0
2	230	50	915	180	0.82	55	60	60	4305	20
3	230	50	905	186	0.84	54	59	60	3680	40
4	230	50	900	190	0.86	53	59	59	2870	60

U = Supply voltage · f = Frequency · n = Speed · Pe = Power input · I = Current draw · LpA_{in} = Sound pressure level inlet side · LwA_{in} = Sound power level inlet side · LwA_{out} = Sound power level outlet side
 qv = Air flow · p_{fs} = Pressure increase



Charts: Air flow 60 Hz

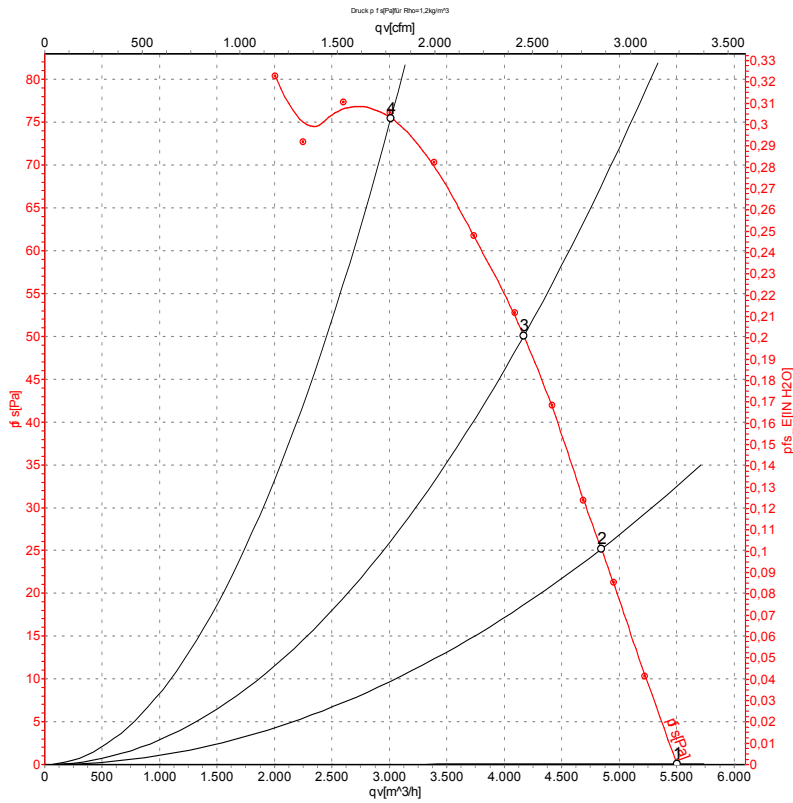

Measurement: LU-106697

Air performance measured as per ISO 5801 Installation category A. For detailed information on the measuring set-up, please contact ebm-papst. Suction-side noise levels: L_{wA} measured as per ISO 13347 / L_{pA} measured with 1m distance to fan axis. The values given are valid under the measuring conditions mentioned above and may vary according to the actual installation situation. With any deviation from the standard set-up, the specific values have to be checked and reviewed with the unit installed.

Measured values

	U	f	n	P _e	I	L _{pA_{in}}	L _{wA_{in}}	L _{wA_{out}}	qv	p _f
	V	Hz	min ⁻¹	W	A	dB(A)	dB(A)	dB(A)	m ³ /h	Pa
1	230	60	1060	241	1.05	58	64	65	5500	0
2	230	60	1035	251	1.09	57	63	63	4845	25
3	230	60	1015	260	1.13	56	62	62	4170	50
4	230	60	990	260	1.16	56	62	62	3015	75

U = Supply voltage · f = Frequency · n = Speed · P_e = Power input · I = Current draw · L_{pA_{in}} = Sound pressure level inlet side · L_{wA_{in}} = Sound power level inlet side · L_{wA_{out}} = Sound power level outlet side
 qv = Air flow · p_f = Pressure increase

