

AC axial fan

sickled blades (S series)



A6E450-AN08-11 ebmpapst Datasheet
 sales@fansco.com
 www.fansco.com

Nominal data

| | | |
|-------------------------------|-------------------|------|
| Type | A6E450-AN08-11 | |
| Motor | M6E074-EI | |
| Phase | | 1~ |
| Nominal voltage | VAC | 230 |
| Frequency | Hz | 50 |
| Type of data definition | | fa |
| Valid for approval / standard | | CE |
| Speed | min ⁻¹ | 900 |
| Power input | W | 145 |
| Current draw | A | 0.64 |
| Motor capacitor | µF | 4 |
| Capacitor voltage | VDB | 400 |
| Max. back pressure | Pa | 45 |
| Max. ambient temperature | °C | 55 |
| Starting current | A | 0.88 |

ml = max. load · me = max. efficiency · fa = running at free air · cs = customer specs · cu = customer unit
 Subject to alterations

Data according to ErP directive

| | |
|-----------------------|--------|
| Installation category | A |
| Efficiency category | Static |
| Variable speed drive | No |
| Specific ratio* | 1.00 |

* Specific ratio = $1 + p_{fs} / 100\,000\text{ Pa}$

| | Actual | Request 2013 | Request 2015 |
|--------------------------------|-------------------|--------------|--------------|
| Overall efficiency η_{es} | 24.6 | 24.6 | 28.6 |
| Efficiency grade N | 36 | 36 | 40 |
| Power input P_e | kW | 0.16 | |
| Air flow q_v | m ³ /h | 2910 | |
| Pressure increase p_{fs} | Pa | 48 | |
| Speed n | min ⁻¹ | 830 | |

Data established at point of optimum efficiency



AC axial fan

sickled blades (S series)

Technical features

| | |
|---|--|
| Mass | 3.7 kg |
| Size | 450 mm |
| Surface of rotor | Coated in black |
| Material of impeller | PP-GF40 plastic |
| Number of blades | 5 |
| Direction of air flow | "V" |
| Direction of rotation | Counter-clockwise, seen on rotor |
| Type of protection | IP 44 |
| Insulation class | "F" |
| Humidity class | F4-1 |
| Max. permissible ambient motor temp. (transp./ storage) | + 80 °C |
| Min. permissible ambient motor temp. (transp./storage) | - 40 °C |
| Mounting position | Shaft horizontal or rotor on bottom; rotor on top on request |
| Condensate discharge holes | Rotor-side |
| Operation mode | S1 |
| Motor bearing | Ball bearing |
| Touch current acc. IEC 60990 (measuring network Fig. 4, TN system) | < 0.75 mA |
| Motor protection | Thermal overload protector (TOP) wired internally |
| Cable exit | Lateral |
| Protection class | I (if protective earth is connected by customer) |
| Product conforming to standard | EN 60335-1; CE |
| Approval | CCC |



Product drawing

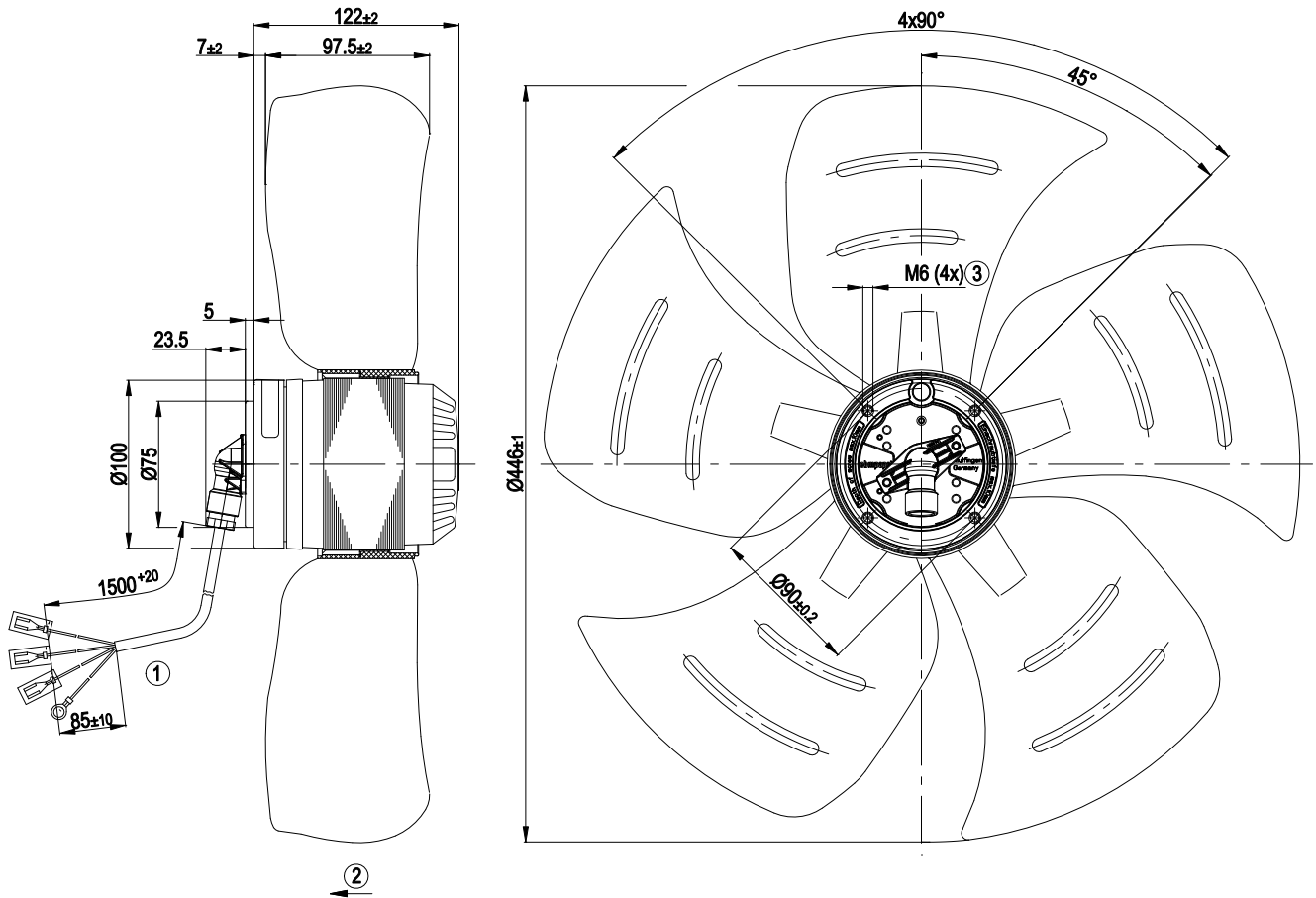

| | |
|---|---|
| 1 | Connection line ETFE AWG 20, 4x brass lead tips crimped |
| 2 | Direction of air flow "V" |
| 3 | Depth of screw max. 10 mm |

Connection screen

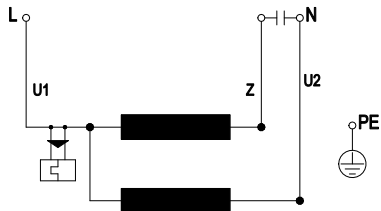

| | | | | | |
|----|--------------|---|-------|----|-------|
| U1 | blue | Z | brown | U2 | black |
| PE | green/yellow | | | | |

Charts: Air flow 50 Hz

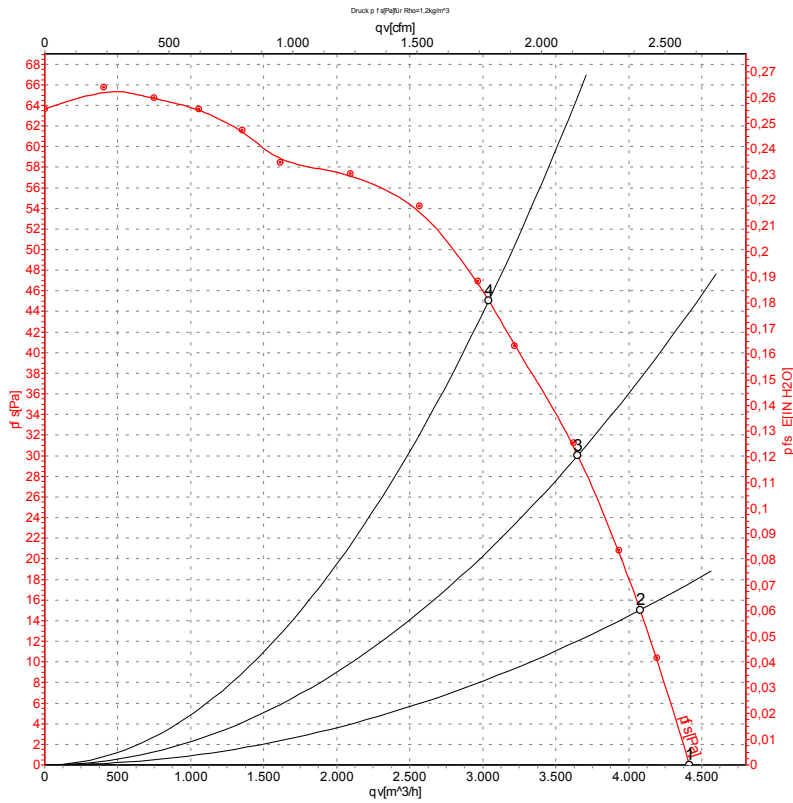

Measurement: LU-38418

Air performance measured as per ISO 5801 Installation category A. For detailed information on the measuring set-up, please contact ebm-papst. Suction-side noise levels: L_{wA} measured as per ISO 13347 / L_{pA} measured with 1m distance to fan axis. The values given are valid under the measuring conditions mentioned above and may vary according to the actual installation situation. With any deviation from the standard set-up, the specific values have to be checked and reviewed with the unit installed.

Measured values

| | U | f | n | P _e | I | qv | P _{fs} |
|---|-----|----|-------------------|----------------|------|-------------------|-----------------|
| | V | Hz | min ⁻¹ | W | A | m ³ /h | Pa |
| 1 | 230 | 50 | 900 | 145 | 0.64 | 4415 | 0 |
| 2 | 230 | 50 | 885 | 149 | 0.65 | 4075 | 15 |
| 3 | 230 | 50 | 870 | 155 | 0.68 | 3650 | 30 |
| 4 | 230 | 50 | 850 | 160 | 0.70 | 3040 | 45 |

U = Supply voltage · f = Frequency · n = Speed · P_e = Power input · I = Current draw · qv = Air flow · P_{fs} = Pressure increase

