

A6E450-AN08-01

AC axial fan

blades with special design (K series)



Nominal data

Type	A6E450-AN08-01	
Motor	M6E074-EI	
Phase		1~
Nominal voltage	VAC	230
Frequency	Hz	50
Type of data definition		fa
Valid for approval / standard		CE
Speed	min ⁻¹	900
Power input	W	145
Current draw	A	0.64
Motor capacitor	µF	4
Capacitor voltage	VDB	400
Max. back pressure	Pa	45
Min. ambient temperature	°C	-25
Max. ambient temperature	°C	55
Starting current	A	0.88

ml = Max. load · me = Max. efficiency · fa = Running at free air · cs = Customer specs · cu = Customer unit
Subject to alterations

Data according to ErP directive

Installation category	A
Efficiency category	Static
Variable speed drive	No
Specific ratio*	1.00

* Specific ratio = $1 + p_g / 100\,000\text{ Pa}$

		Actual	Request 2013	Request 2015
Overall efficiency η_{es}	%	24.6	24.6	28.6
Efficiency grade N		36	36	40
Power input P_e	kW	0.16		
Air flow q_v	m ³ /h	2910		
Pressure increase p_{fs}	Pa	48		
Speed n	min ⁻¹	830		

Data definition with optimum efficiency.

LU-121014

The ErP data is determined using a motor-impeller combination in a standardised measurement configuration.



Technical features

Mass	4 kg
Size	450 mm
Surface of rotor	Coated in black
Material of blades	PP plastic
Number of blades	5
Direction of air flow	"V"
Direction of rotation	Counter-clockwise, seen on rotor
Type of protection	IP 44; Depending on installation and position as per EN 60034-5
Insulation class	"F"
Humidity class	F4-1
Max. permissible ambient motor temp. (transp./ storage)	+ 80 °C
Min. permissible ambient motor temp. (transp./storage)	- 40 °C
Mounting position	Shaft horizontal or rotor on bottom; rotor on top on request
Condensate discharge holes	Rotor-side
Operation mode	S1
Motor bearing	Ball bearing
Touch current acc. IEC 60990 (measuring network Fig. 4, TN system)	< 0.75 mA
Motor protection	Thermal overload protector (TOP) wired internally
Cable exit	Lateral
Protection class	I (if protective earth is connected by customer)
Product conforming to standard	EN 60335-1; CE
Approval	EAC

Product drawing

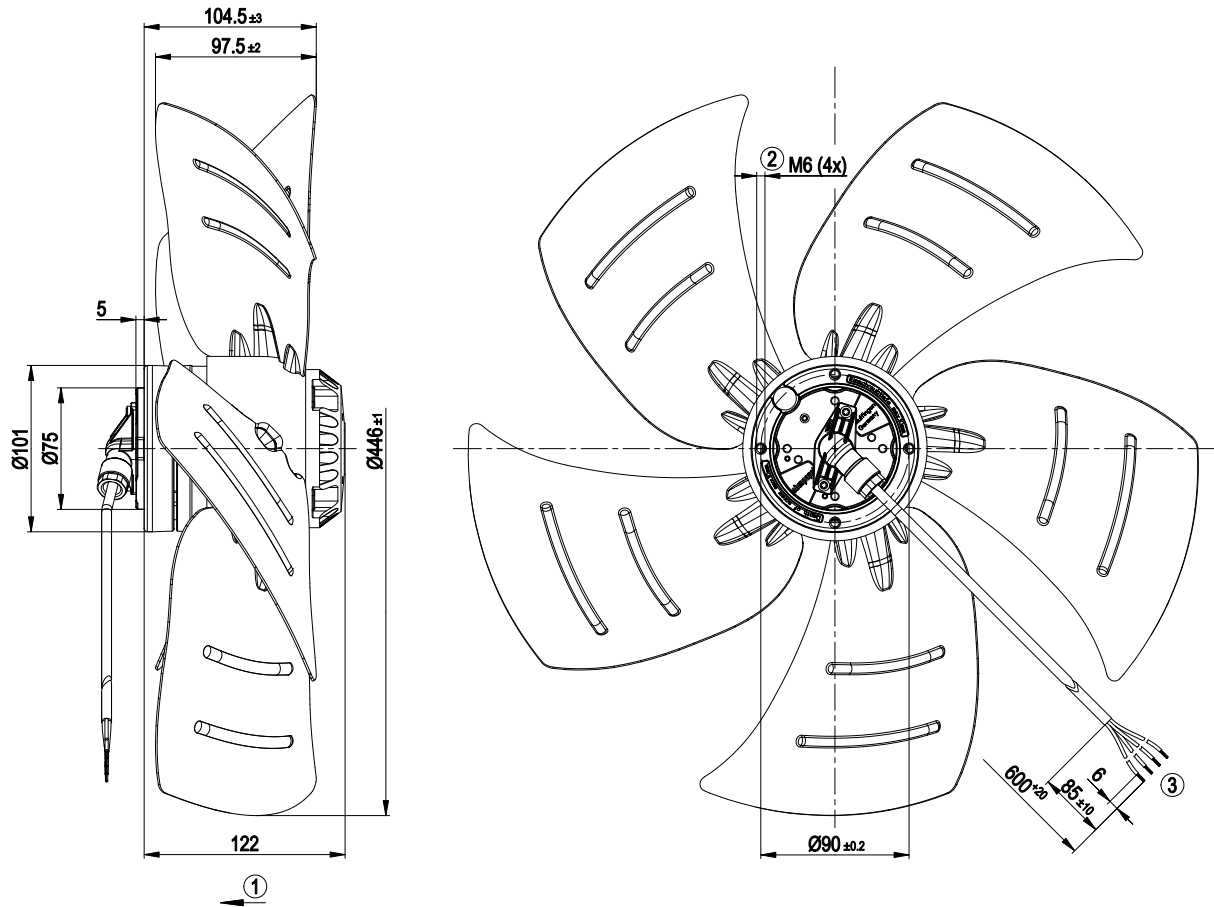

1	Direction of air flow "V"
2	Depth of screw max. 10 mm
3	Connection line ETFE AWG20, 4 x brass lead tips crimped

Connection screen

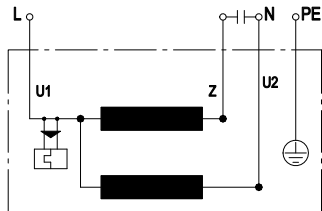

U1	blue	Z	brown	U2	black
PE	green/yellow				

Charts: Air flow 50 Hz

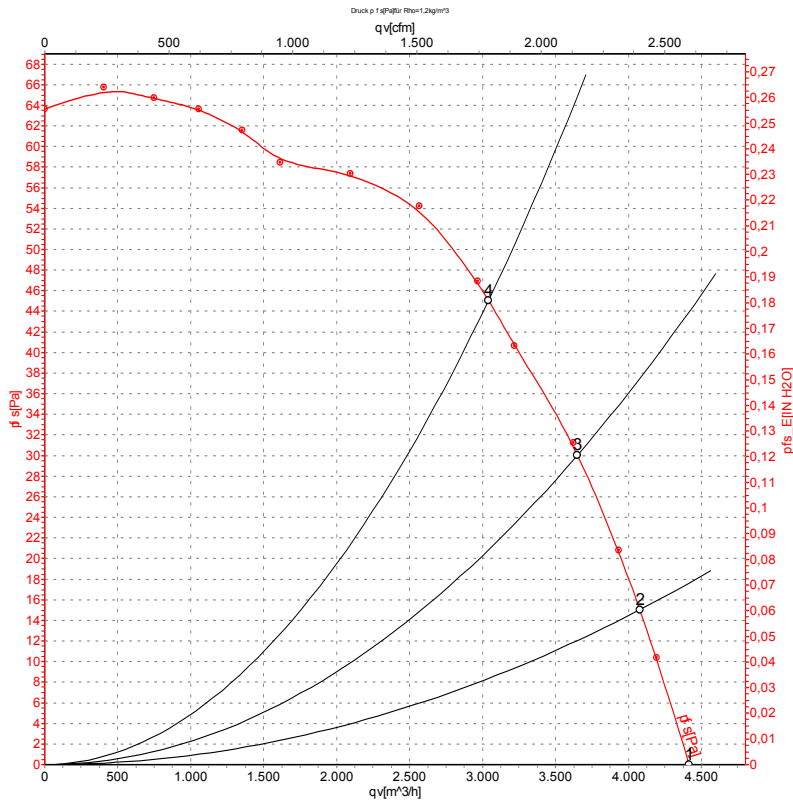

Air performance measured as per ISO 5801 Installation category A. For detailed information on the measuring set-up, please contact ebm-papst. Suction-side noise levels: L_{WA} measured as per ISO 13347 / L_{pA} measured with 1m distance to fan axis. The values given are valid under the measuring conditions mentioned above and may vary according to the actual installation situation. With any deviation from the standard set-up, the specific values have to be checked and reviewed with the unit installed.

Measured values

	U	f	n	P _e	I	qv	P _{fs}
	V	Hz	min ⁻¹	W	A	m ³ /h	Pa
1	230	50	900	145	0.64	4415	0
2	230	50	885	149	0.65	4075	15
3	230	50	870	155	0.68	3650	30
4	230	50	850	160	0.70	3040	45

U = Supply voltage · f = Frequency · n = Speed · P_e = Power input · I = Current draw · qv = Air flow · P_{fs} = Pressure increase

