

A6E450-AN06-28 ebmpapst Datasheet

sales@fansco.com

www.fansco.com

Nominal data

Type	A6E450-AN06-28		
Motor	M6E094-FA		
Phase		1~	1~
Nominal voltage	VAC	230	230
Frequency	Hz	50	60
Method of obtaining data		ml	ml
Valid for approval/standard		CE	CE
Speed (rpm)	min ⁻¹	890	990
Power consumption	W	160	220
Current draw	A	0.7	1.0
Capacitor	μF	5	5
Capacitor voltage	VDB	400	400
Capacitor standard		S0 (CE)	S0 (CE)
Max. back pressure	Pa	55	65
Max. back pressure	in. wg	0.22	0.26
Min. ambient temperature	°C	-40	-40
Max. ambient temperature	°C	75	75
Starting current	A	1.3	1.2

ml = Max. load · me = Max. efficiency · fa = Free air · cs = Customer specification · ce = Customer equipment
Subject to change

Data according to Commission Regulation (EU) 327/2011 (EN 17166)

		Actual	Req. 2015			
01 Overall efficiency η_{es}	%	28.6	28.6	09 Power consumption P_e	kW	0.15
02 Measurement category		A		09 Air flow q_v	m ³ /h	3175
03 Efficiency category		Static		09 Pressure increase p_{fs}	Pa	51
04 Efficiency grade N		40	40	10 Speed (rpm) n	min ⁻¹	900
05 Variable speed drive		No		11 Specific ratio*		1.00

Data obtained at optimum efficiency level.

The ErP data is determined using a motor-impeller combination in a standardized measurement setup.

* Specific ratio = $1 + p_g / 100\,000\text{ Pa}$

LU-204122



Technical description

Weight	5.9 kg
Size	450 mm
Motor size	94
Rotor surface	Painted black
Terminal box material	PP plastic
Blade material	Press-fitted sheet steel blank, sprayed with PP plastic
Number of blades	5
Airflow direction	V
Direction of rotation	Counterclockwise, viewed toward rotor
Degree of protection	IP54
Insulation class	"F"
Moisture (F) / Environmental (H) protection class	H2
Ambient temperature note	Occasional start-up at temperatures between -40°C and -25°C is permitted. For continuous operation at ambient temperatures below -25°C (such as refrigeration applications), use must be made of a fan design with special low-temperature bearings.
Max. permitted ambient temp. for motor (transport/storage)	+80 °C
Min. permitted ambient temp. for motor (transport/storage)	-40 °C
Installation position	Shaft horizontal or rotor on bottom; rotor on top on request
Condensation drainage holes	On rotor side
Mode	S1
Motor bearing	Ball bearing
Touch current according to IEC 60990 (measuring circuit Fig. 4, TN system)	<= 3.5 mA
Electrical hookup	Terminal box
Motor protection	Thermal overload protector (TOP) with basic insulation
Protection class	I (with customer connection of protective earth)
Motor capacitor according to EN 60252-1 in safety protection class	S0
Conformity with standards	EN 60034-1; CE
Approval	EAC

AC axial fan

sickle-shaped blades (S series)

Product drawing

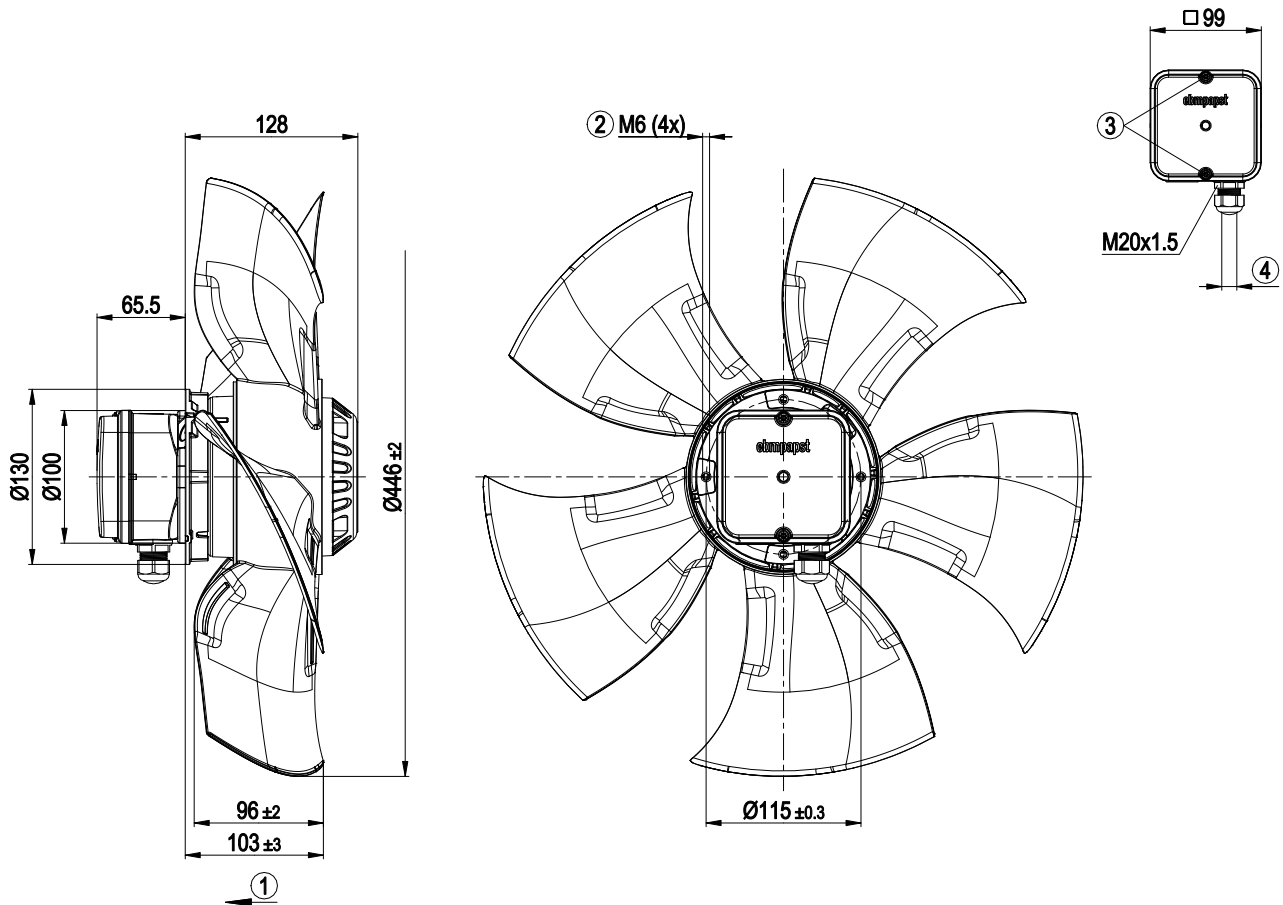

1	Airflow direction "V"
2	Max. clearance for screw 12 mm
3	Tightening torque 1.5 ± 0.2 Nm
4	Cable diameter min. 6 mm, max. 12 mm, tightening torque 2 ± 0.3 Nm



AC axial fan

sickle-shaped blades (S series)

Connection diagram

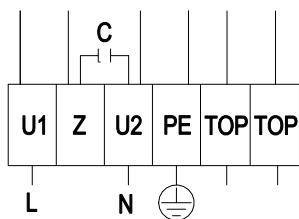

L	= U1 = blue	Z	brown	N	= U2 = black
PE	green/yellow	TOP	gray		



Curves: Air performance 50 Hz

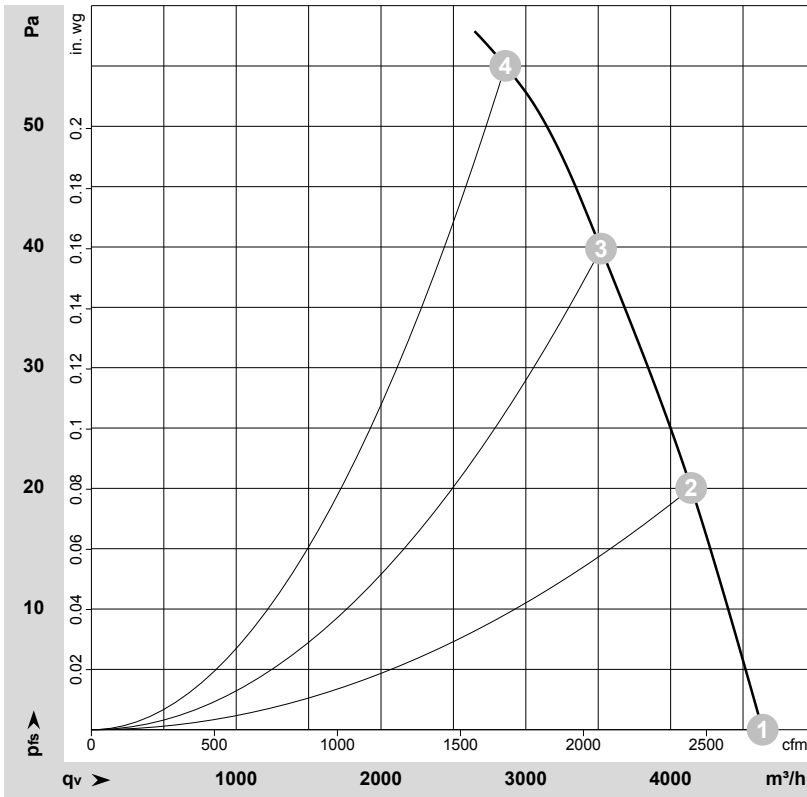

$\rho = 1.15 \text{ kg/m}^3 \pm 2 \%$

Measurement: LU-204122-1

Air performance measured according to ISO 5801 installation category A. For detailed information on the measurement setup, contact ebmpapst. Intake sound level: Sound power level according to ISO 13347 / sound pressure level measured at 1 m distance from fan axis. The values given are valid under the specified measuring conditions and may vary due to conditions of installation. For deviations from the standard configuration, the parameters have to be checked on the installed unit.

Measured values

	Wired	U	f	n	P _e	I	q _v	p _{fs}	q _v	p _{fs}
		V	Hz	min ⁻¹	W	A	m ³ /h	Pa	cfm	in. wg
1	1~	230	50	920	138	0.60	4635	0	2730	0.00
2	1~	230	50	910	145	0.64	4140	20	2440	0.08
3	1~	230	50	900	152	0.67	3520	40	2070	0.16
4	1~	230	50	890	160	0.70	2860	55	1685	0.22

Wired = Wiring · U = Voltage · f = Frequency · n = Speed (rpm) · P_e = Power consumption · I = Current draw · q_v = Air flow · p_{fs} = Pressure increase



Curves: Air performance 60 Hz

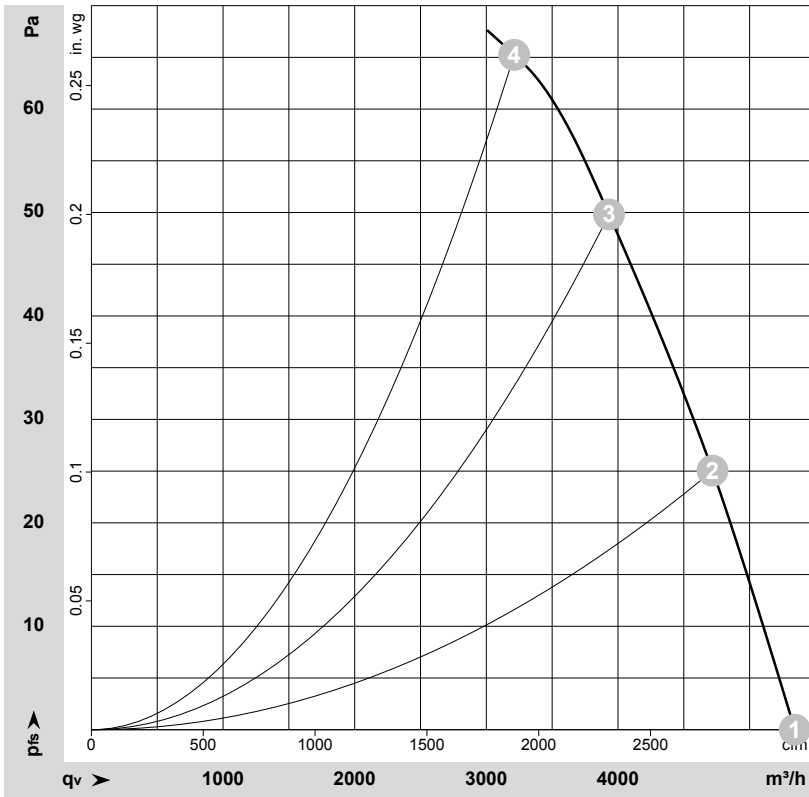

$\rho = 1.15 \text{ kg/m}^3 \pm 2 \%$

Measurement: LU-204139-1

Air performance measured according to ISO 5801 installation category A. For detailed information on the measurement setup, contact ebmpapst. Intake sound level: Sound power level according to ISO 13347 / sound pressure level measured at 1 m distance from fan axis. The values given are valid under the specified measuring conditions and may vary due to conditions of installation. For deviations from the standard configuration, the parameters have to be checked on the installed unit.

Measured values

	Wired	U	f	n	P _e	I	q _v	p _{fs}	q _v	p _{fs}
		V	Hz	min ⁻¹	W	A	m ³ /h	Pa	cfm	in. wg
1	1~	230	60	1060	201	0.88	5345	0	3145	0.00
2	1~	230	60	1035	209	0.91	4720	25	2775	0.10
3	1~	230	60	1010	216	0.94	3930	50	2315	0.20
4	1~	230	60	990	220	1.00	3210	65	1890	0.26

Wired = Wiring · U = Voltage · f = Frequency · n = Speed (rpm) · P_e = Power consumption · I = Current draw · q_v = Air flow · p_{fs} = Pressure increase

