

A6E450-AM13-01 ebmpapst Datasheet

sales@fansco.com

www.fansco.com

Nominal data

Type	A6E450-AM13-01		
Motor	M6E074-EI		
Phase		1~	1~
Nominal voltage	VAC	230	230
Frequency	Hz	50	60
Method of obtaining data		ml	ml
Valid for approval/standard		CE	CE
Speed (rpm)	min ⁻¹	750	700
Power consumption	W	125	150
Current draw	A	0.56	0.66
Capacitor	µF	3	3
Capacitor voltage	VDB	400	400
Capacitor standard		S0 (CE)	S0 (CE)
Max. back pressure	Pa	40	38
Max. back pressure	in. wg	0.16	0.15
Min. ambient temperature	°C	-25	-25
Max. ambient temperature	°C	70	50
Starting current	A	0.68	0.68

ml = Max. load · me = Max. efficiency · fa = Free air · cs = Customer specification · ce = Customer equipment
Subject to change



Technical description

Weight	4.6 kg
Fan size	450 mm
Rotor surface	Painted black
Blade material	Press-fitted sheet steel blank, sprayed with PP plastic
Number of blades	5
Airflow direction	"V"
Direction of rotation	Counterclockwise, viewed toward rotor
Degree of protection	IP44; installation- and position-dependent as per EN 60034-5
Insulation class	"F"
Moisture (F) / Environmental (H) protection class	H1
Max. permitted ambient temp. for motor (transport/storage)	+ 80 °C
Min. permitted ambient temp. for motor (transport/storage)	- 40 °C
Installation position	Shaft horizontal or rotor on bottom; rotor on top on request
Condensation drainage holes	On rotor side
Mode	S1
Motor bearing	Ball bearing
Touch current according to IEC 60990 (measuring circuit Fig. 4, TN system)	< 0.75 mA
Motor protection	Thermal overload protector (TOP) internally connected
With cable	Variable
Protection class	I (with customer connection of protective earth)
Conformity with standards	EN 60335-1; CE
Approval	EAC

AC axial fan

sickle-shaped blades (S series), single-intake

Product drawing

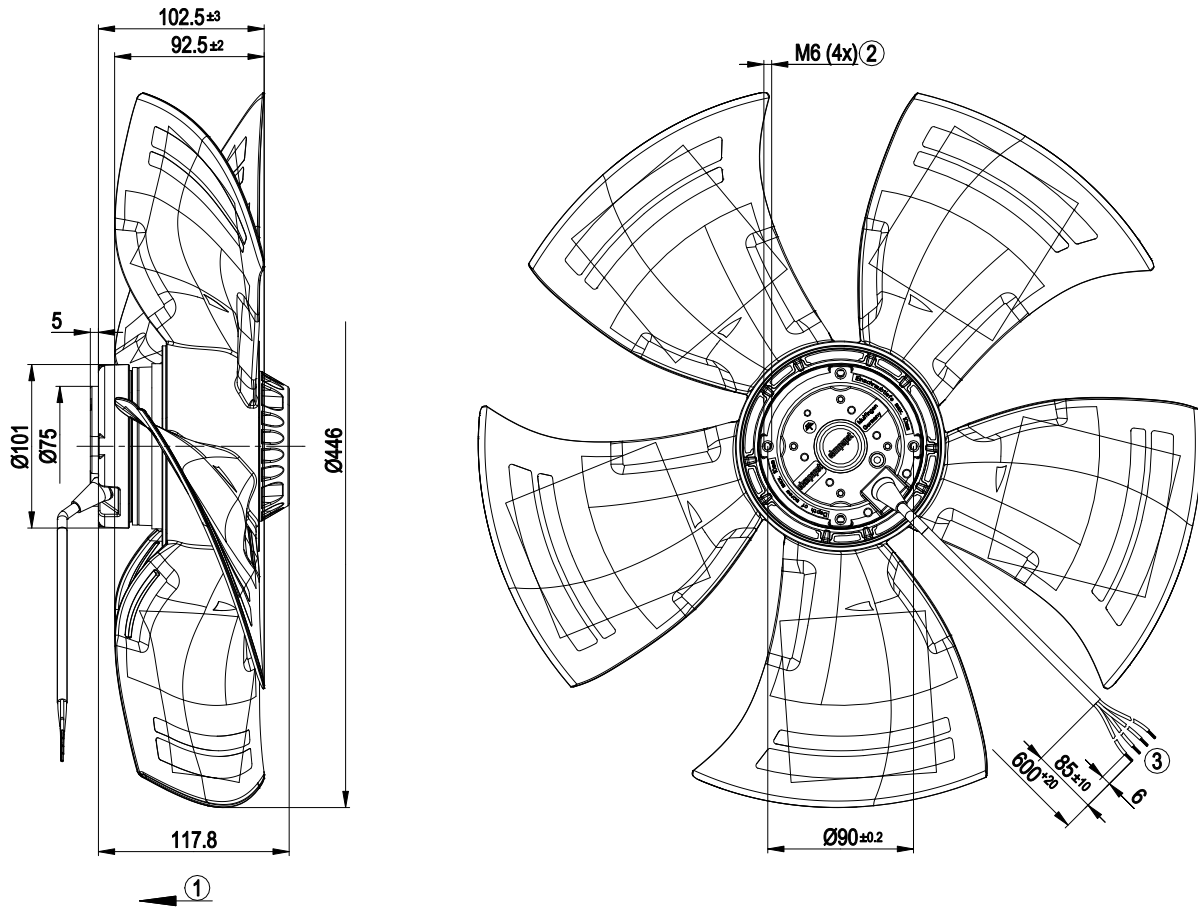

1	Direction of air flow "V"
2	Max. clearance for screw 10 mm
3	Cable silicone 4G 0.5 mm ² , 4x crimped splices

Connection diagram

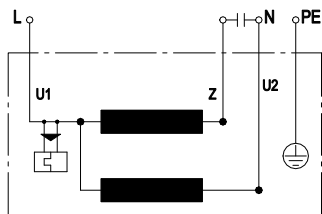

U1	blue	Z	brown	U2	black
PE	green/yellow				



Curves: Air performance 50 Hz

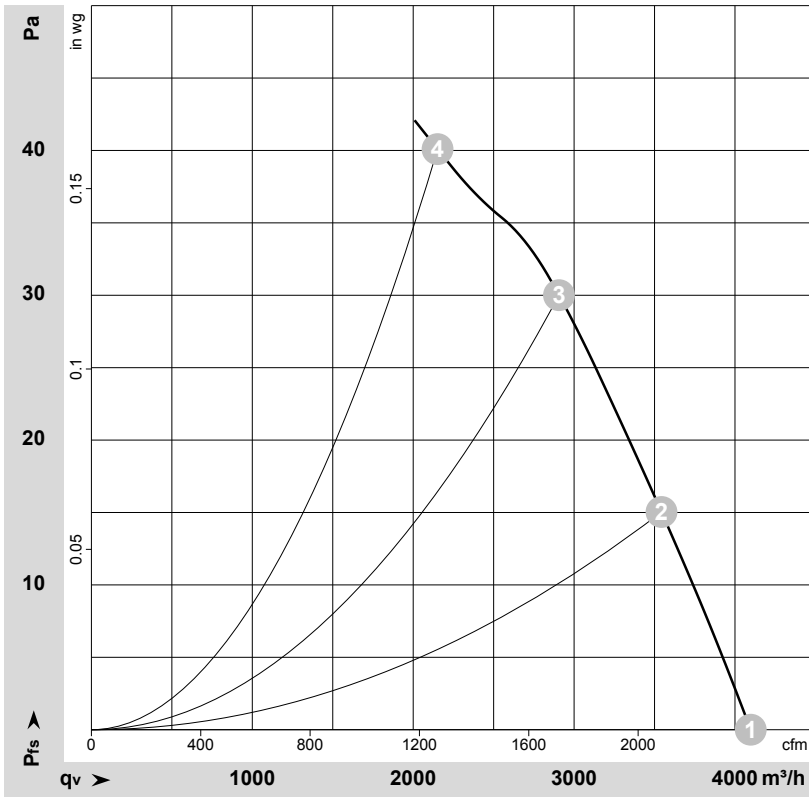

$\rho = 1.15 \text{ kg/m}^3 \pm 2 \%$

Measurement: LU-163934-1

Air performance measured according to ISO 5801 installation category A. For detailed information on the measurement setup, contact ebmpapst. Intake sound level: Sound power level according to ISO 13347 / sound pressure level measured at 1 m distance from fan axis. The values given are valid under the specified measuring conditions and may vary due to conditions of installation. For deviations from the standard configuration, the parameters have to be checked on the installed unit.

Measured values

	U	f	n	P _e	I	LpA _{in}	LwA _{in}	q _v	p _{fs}	q _v	p _{fs}
	V	Hz	min ⁻¹	W	A	dB(A)	dB(A)	m ³ /h	Pa	cfm	in. wg
1	230	50	840	110	0.48	57	63	4100	0	2410	0.00
2	230	50	810	116	0.51	54	60	3545	15	2085	0.06
3	230	50	780	120	0.53	50	57	2905	30	1710	0.12
4	230	50	750	125	0.56	50	57	2150	40	1265	0.16

U = Power supply · f = Frequency · n = Speed (rpm) · P_e = Power consumption · I = Current draw · LpA_{in} = Sound pressure level intake side · LwA_{in} = Sound power level intake side
 q_v = Air flow · p_{fs} = Pressure increase



Curves: Air performance 60 Hz

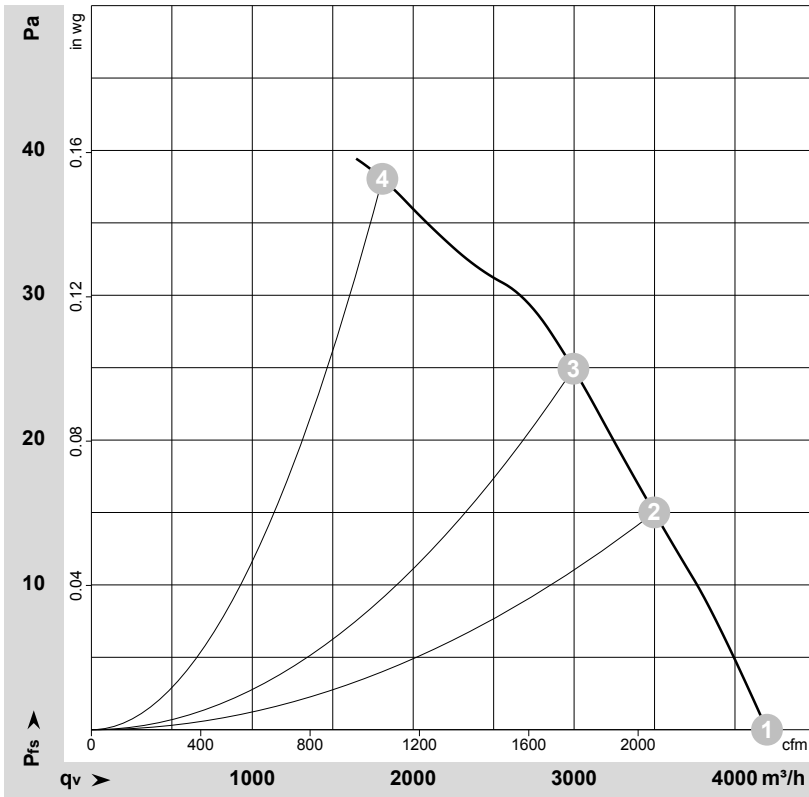

$\rho = 1.15 \text{ kg/m}^3 \pm 2 \%$

Measurement: LU-164002-1

Air performance measured according to ISO 5801 installation category A. For detailed information on the measurement setup, contact ebmpapst. Intake sound level: Sound power level according to ISO 13347 / sound pressure level measured at 1 m distance from fan axis. The values given are valid under the specified measuring conditions and may vary due to conditions of installation. For deviations from the standard configuration, the parameters have to be checked on the installed unit.

Measured values

	U	f	n	P _e	I	LpA _{in}	LwA _{in}	q _v	p _{fs}	q _v	p _{fs}
	V	Hz	min ⁻¹	W	A	dB(A)	dB(A)	m ³ /h	Pa	cfm	in. wg
1	230	60	855	145	0.63	57	64	4200	0	2470	0.00
2	230	60	800	146	0.63	55	61	3500	15	2060	0.06
3	230	60	765	147	0.64	52	59	2995	25	1765	0.10
4	230	60	700	150	0.66	51	58	1810	38	1065	0.15

U = Power supply · f = Frequency · n = Speed (rpm) · P_e = Power consumption · I = Current draw · LpA_{in} = Sound pressure level intake side · LwA_{in} = Sound power level intake side
 q_v = Air flow · p_{fs} = Pressure increase



Foglio ISO 5457 - A3T - OP - F Software: Pro/E WF 5 Database: PDM-Link 9.1 Ogni utilizzo non autorizzato di questo disegno, copia, riproduzione o invio a terzi, richiede l'esplicita approvazione da parte di ebm-papst S.r.l. - Ogni violazione sarà perseguita in sede civile e penale

1	2	3	4	5	6	7	8
Materiale	S235JR EN 10025-2						
Trattamento	Sgrassaggio acido + passivazione						
Verniciatura	Cataforesi + Poliестere						
Note Verniciatura							
Colore	RAL 9005						
Peso	ca. 2.32 Kg						
Profilo	236						
Famiglia							
Cod. casa madre	25938-2-4039 Mod.						

Stato disegno: Released

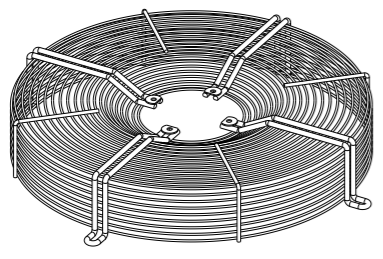
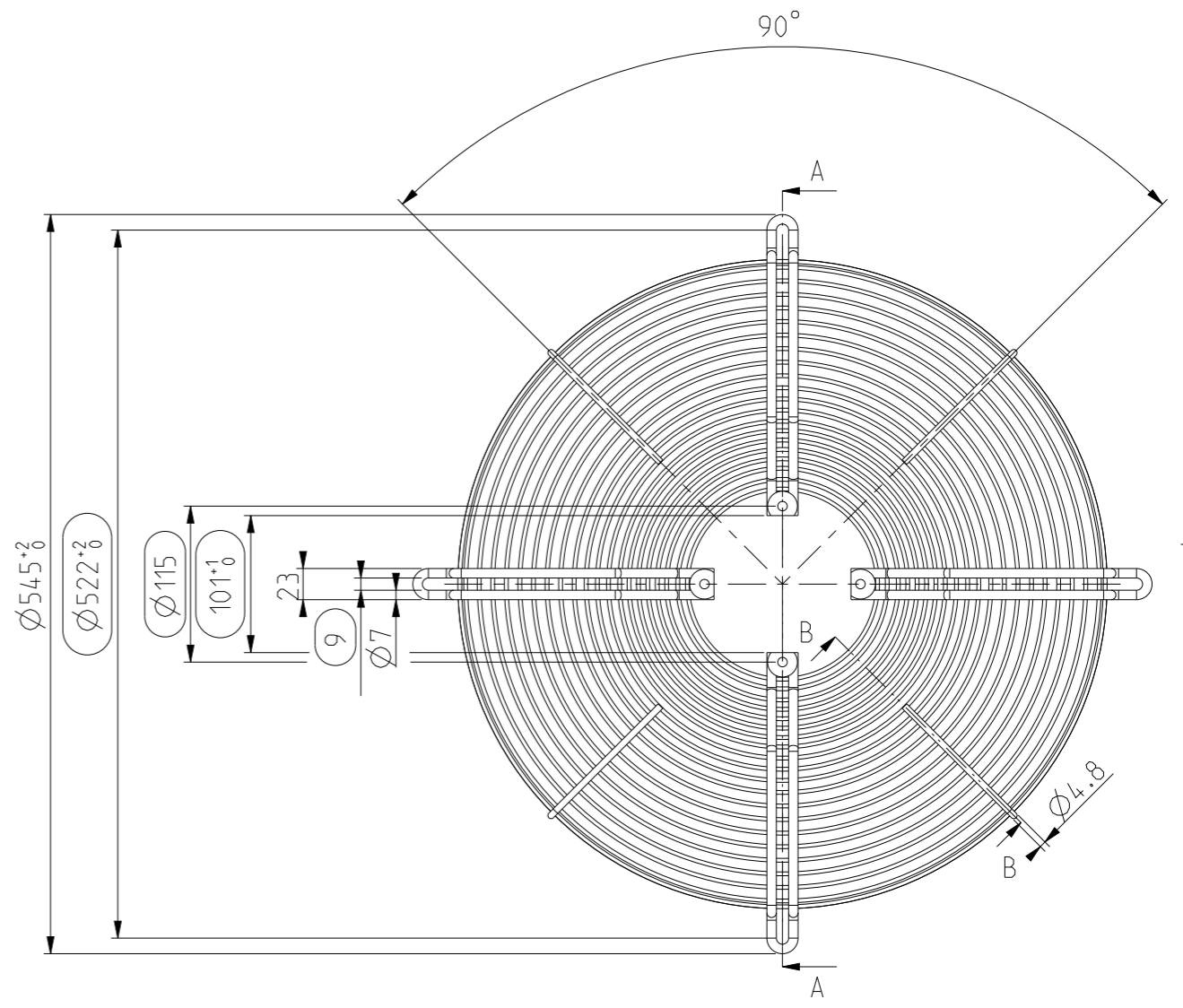
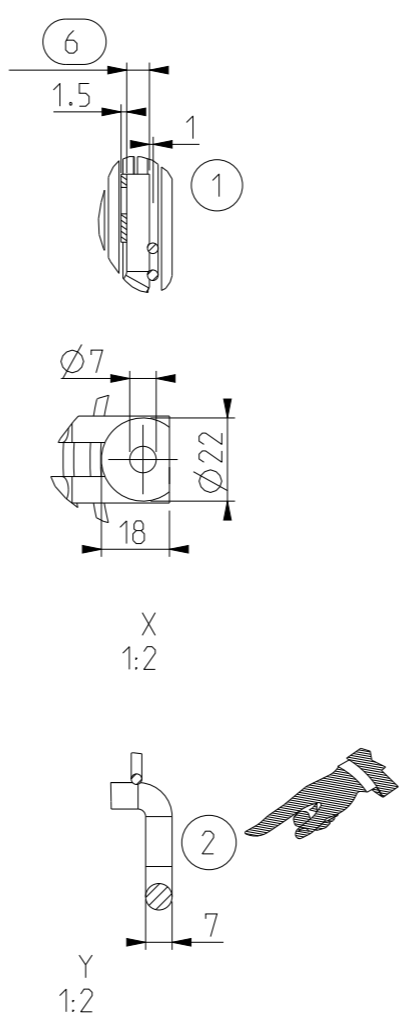
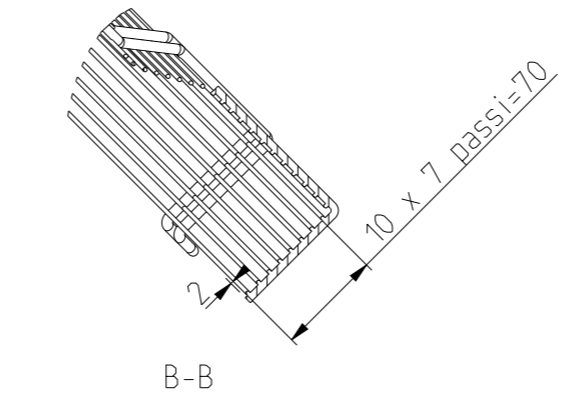
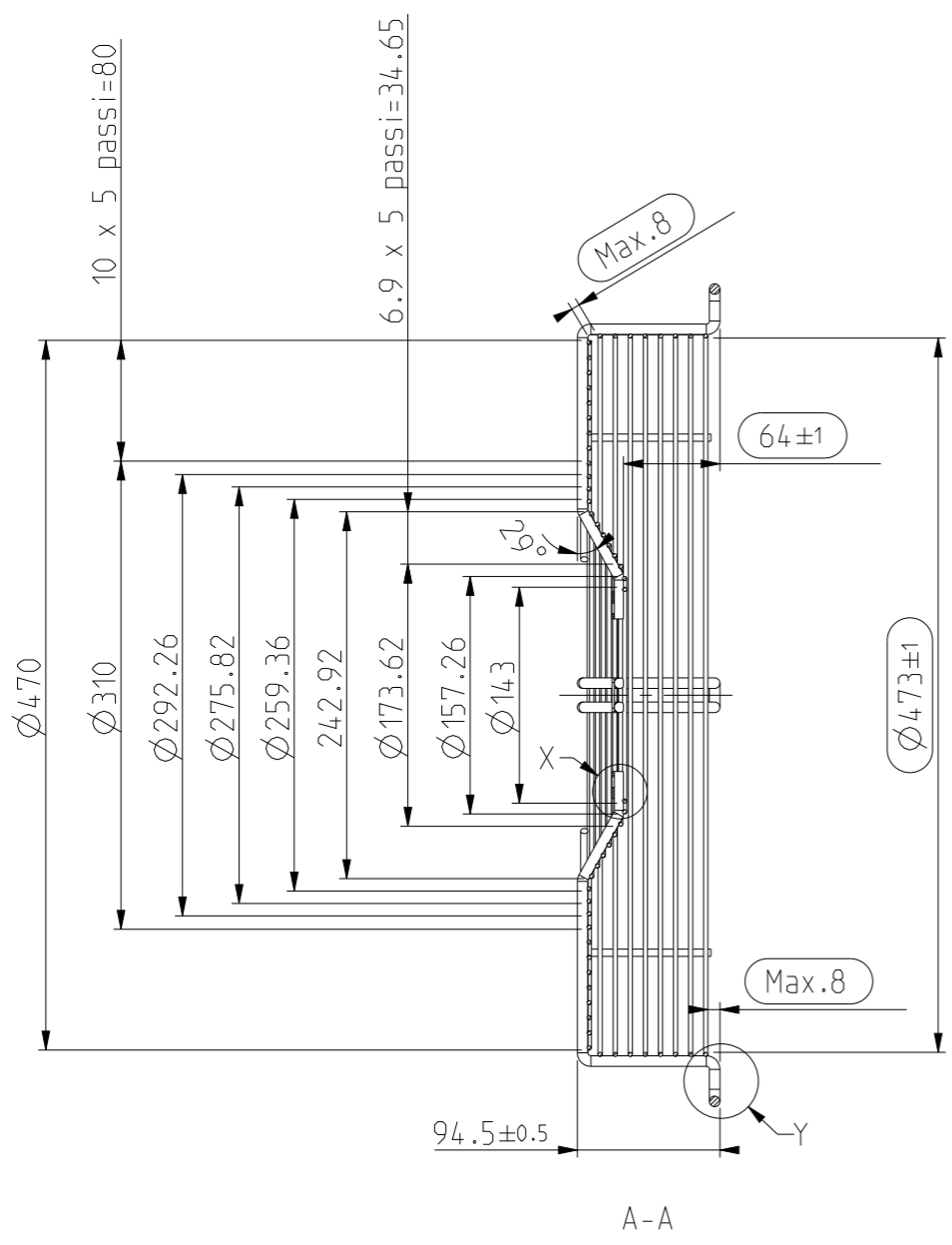

1:10

Per le quote mancanti fare riferimento al modello 3D
 Le dimensioni si riferiscono al pezzo non verniciato
 Deve essere garantita la distanza di sicurezza di 8mm tra tutti gli anelli
 Raggi non quotati R2

Quota d'ispezione

Quote senza ind. di tolleranza	ebmpapst					
ISO 2768 mK-E	ebm-papst S.r.l. - Via Cornaggia 108 I-22076 Mozzate (CO)					
Scala	Descrizione					
1:5	Griglia di protezione d.450 per assiale "V" motore AC 094 - HyBlade					
Distribuzione	Codice	CAD	Data	Nome		
Fornitore	106FG0702	0000003644	Disegnato	18.01.11	L.Cappelletti	
Pubblica	GR-0450-00978S	Revisione	Controllato	18.01.11	S.Folpini	
		2.6	Stato disegno:	Released		Foglio 1 di 1