

A6E400-AP10-01

AC axial fan

sickled blades (S series)



A6E400-AP10-01 ebmpapst Datasheet
sales@fansco.com
www.fansco.com

Nominal data

Type	A6E400-AP10-01		
Motor	M6E074-DF		
Phase		1~	1~
Nominal voltage	VAC	230	230
Frequency	Hz	50	60
Type of data definition		fa	fa
Valid for approval / standard		-	-
Speed	min ⁻¹	940	1080
Power input	W	120	170
Current draw	A	0.55	0.75
Motor capacitor	µF	3	3
Capacitor voltage	VDB	450	400
Max. back pressure	Pa	50	40
Min. ambient temperature	°C	-25	-25
Max. ambient temperature	°C	55	35
Starting current	A	0.9	0.88

ml = Max. load · me = Max. efficiency · fa = Running at free air · cs = Customer specs · cu = Customer unit
Subject to alterations



Technical features

Mass	3.7 kg
Size	400 mm
Surface of rotor	Coated in black
Material of impeller	Sheet steel, coated in black
Number of blades	5
Direction of air flow	"V"
Direction of rotation	Counter-clockwise, seen on rotor
Type of protection	IP 44; Depending on installation and position as per EN 60034-5
Insulation class	"F"
Humidity class	F1-2
Max. permissible ambient motor temp. (transp./ storage)	+ 80 °C
Min. permissible ambient motor temp. (transp./storage)	- 40 °C
Mounting position	Shaft horizontal or rotor on bottom; rotor on top on request
Condensate discharge holes	Rotor-side
Operation mode	S1
Motor bearing	Ball bearing
Touch current acc. IEC 60990 (measuring network Fig. 4, TN system)	< 0.75 mA
Motor protection	Thermal overload protector (TOP) wired internally
Cable exit	Variable
Protection class	I (if protective earth is connected by customer)
Product conforming to standard	EN 60335-1



Product drawing

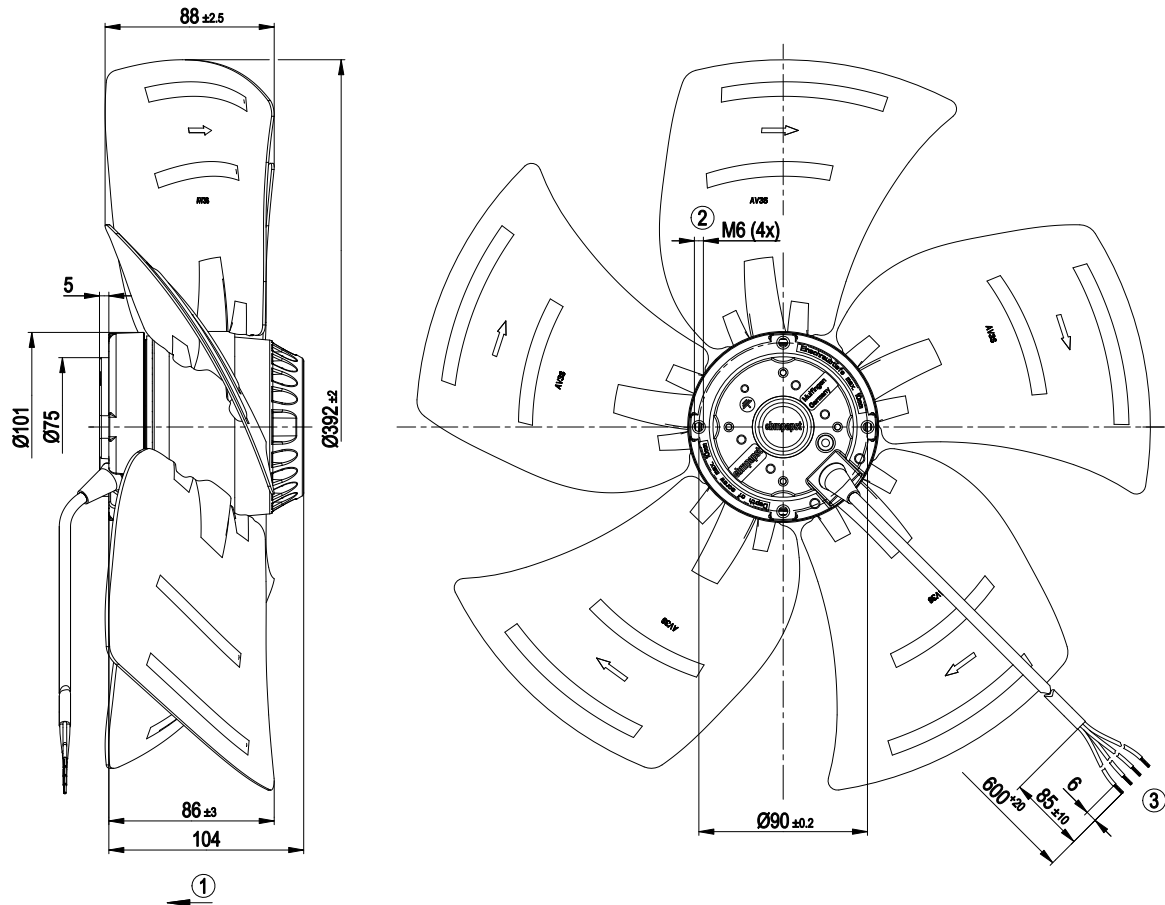

1	Direction of air flow "V"
2	Depth of screw max. 10 mm
3	Connection line silicone 4G 0.5 mm ² , 4x lead tips crimped

Connection screen

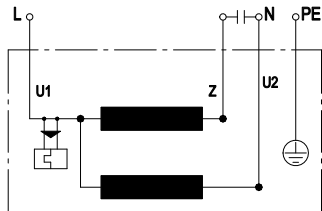

U1	blue	Z	brown	U2	black
PE	green/yellow				



Charts: Air flow 50 Hz

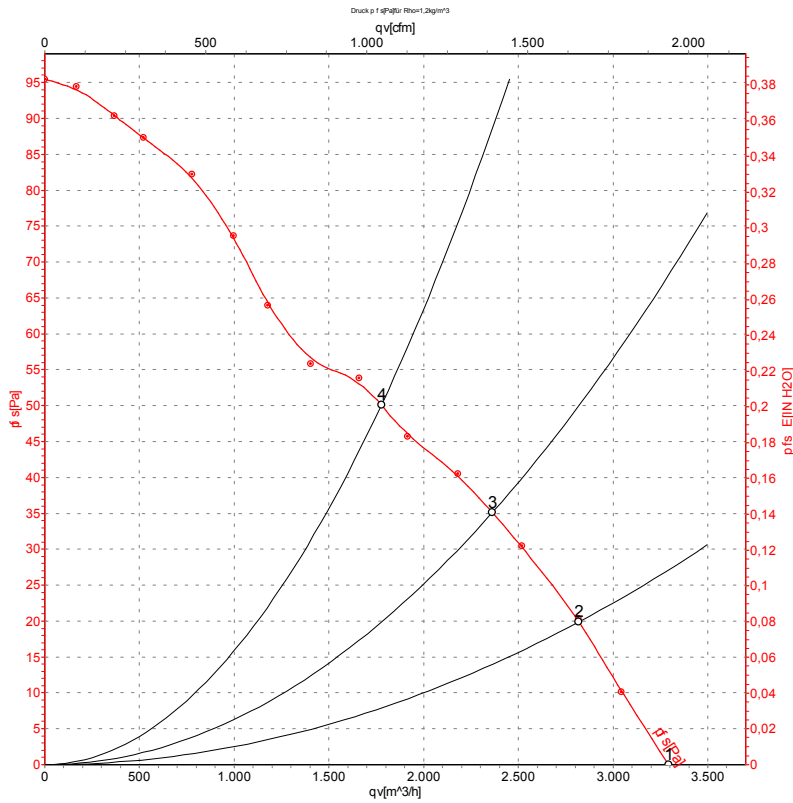

Measurement: LU-27954

Air performance measured as per ISO 5801 Installation category A. For detailed information on the measuring set-up, please contact ebm-papst. Suction-side noise levels: L_{WA} measured as per ISO 13347 / L_{pA} measured with 1m distance to fan axis. The values given are valid under the measuring conditions mentioned above and may vary according to the actual installation situation. With any deviation from the standard set-up, the specific values have to be checked and reviewed with the unit installed.

Measured values

	U	f	n	P _e	I	qv	P _{fs}
	V	Hz	min ⁻¹	W	A	m ³ /h	Pa
1	230	50	940	120	0.55	3295	0
2	230	50	930	127	0.57	2820	20
3	230	50	920	131	0.59	2365	35
4	230	50	895	139	0.62	1775	50

U = Supply voltage · f = Frequency · n = Speed · P_e = Power input · I = Current draw · qv = Air flow · P_{fs} = Pressure increase



Charts: Air flow 60 Hz

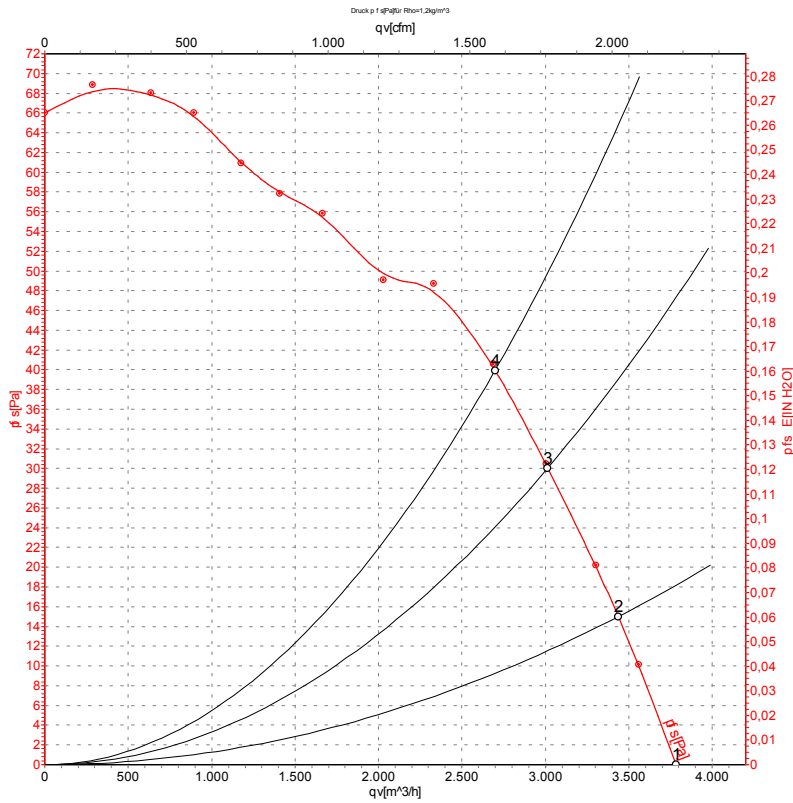

Measurement: LU-27955

Air performance measured as per ISO 5801 Installation category A. For detailed information on the measuring set-up, please contact ebm-papst. Suction-side noise levels: L_{wA} measured as per ISO 13347 / L_{pA} measured with 1m distance to fan axis. The values given are valid under the measuring conditions mentioned above and may vary according to the actual installation situation. With any deviation from the standard set-up, the specific values have to be checked and reviewed with the unit installed.

Measured values

	U	f	n	P _e	I	qv	p _{fs}
	V	Hz	min ⁻¹	W	A	m ³ /h	Pa
1	230	60	1080	170	0.75	3780	0
2	230	60	1065	171	0.75	3435	15
3	230	60	1035	176	0.76	3015	30
4	230	60	1015	178	0.78	2700	40

U = Supply voltage · f = Frequency · n = Speed · P_e = Power input · I = Current draw · qv = Air flow · p_{fs} = Pressure increase

